

Façade Structurelle

Façade Demi-Structurelle

Façade Mur Rideau

Système Ergolux

Brise Soleil

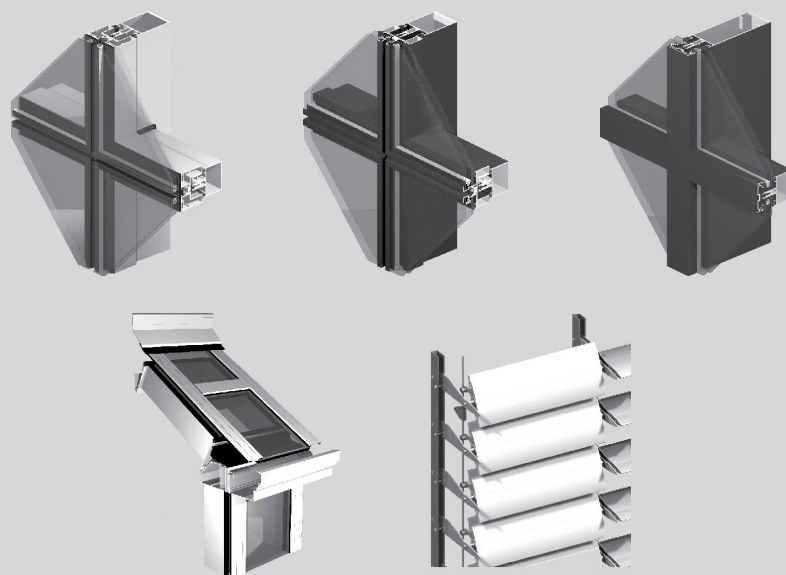

Système

FL

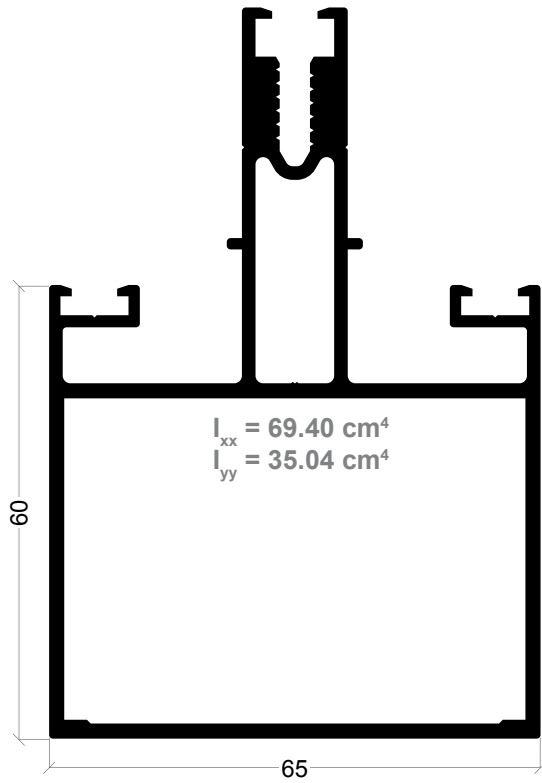

FL-14
Montant de 60 mm

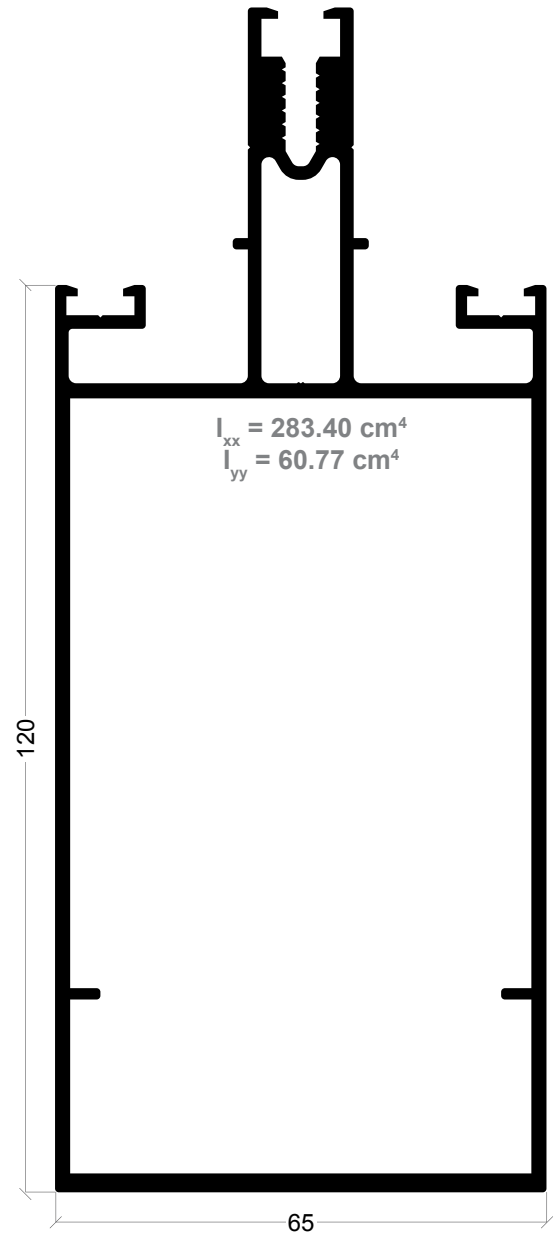

FL-13
Montant de 120 mm

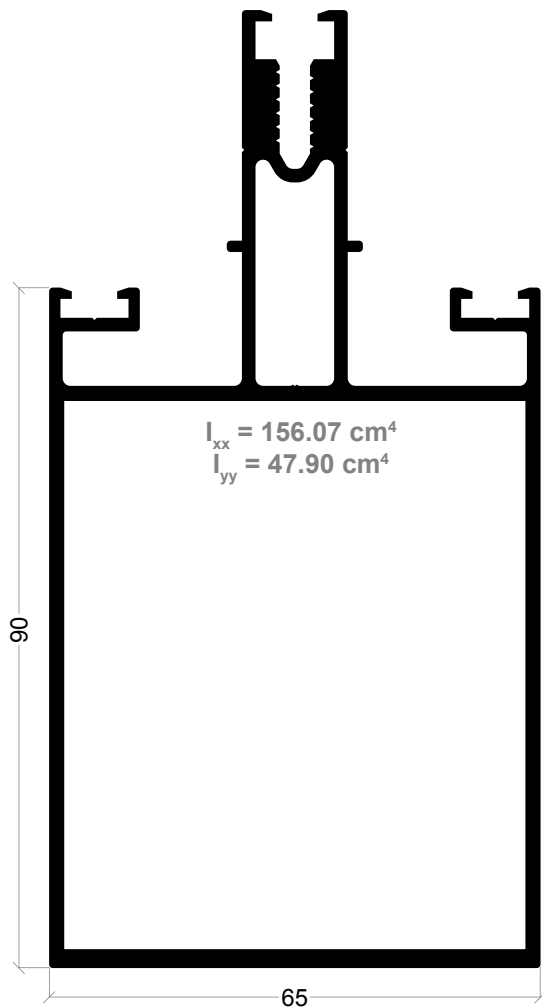

FL-10
Montant de 90 mm

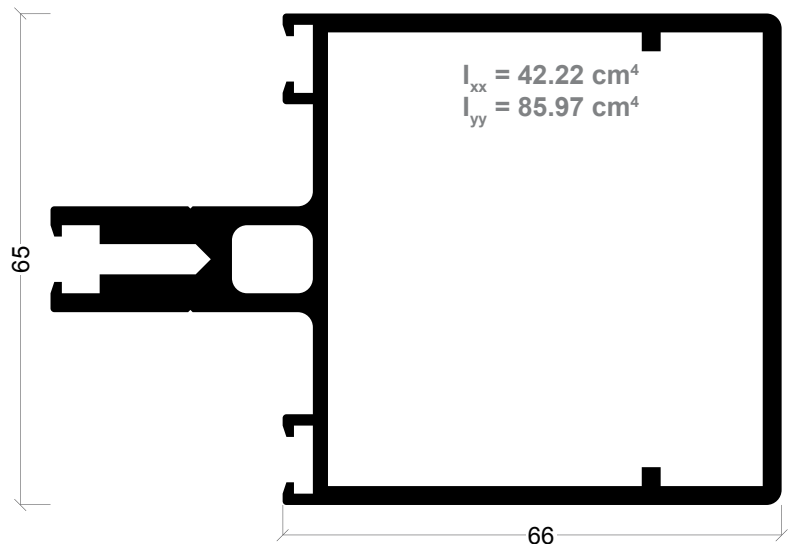

FL-80
Traverse 66 mm

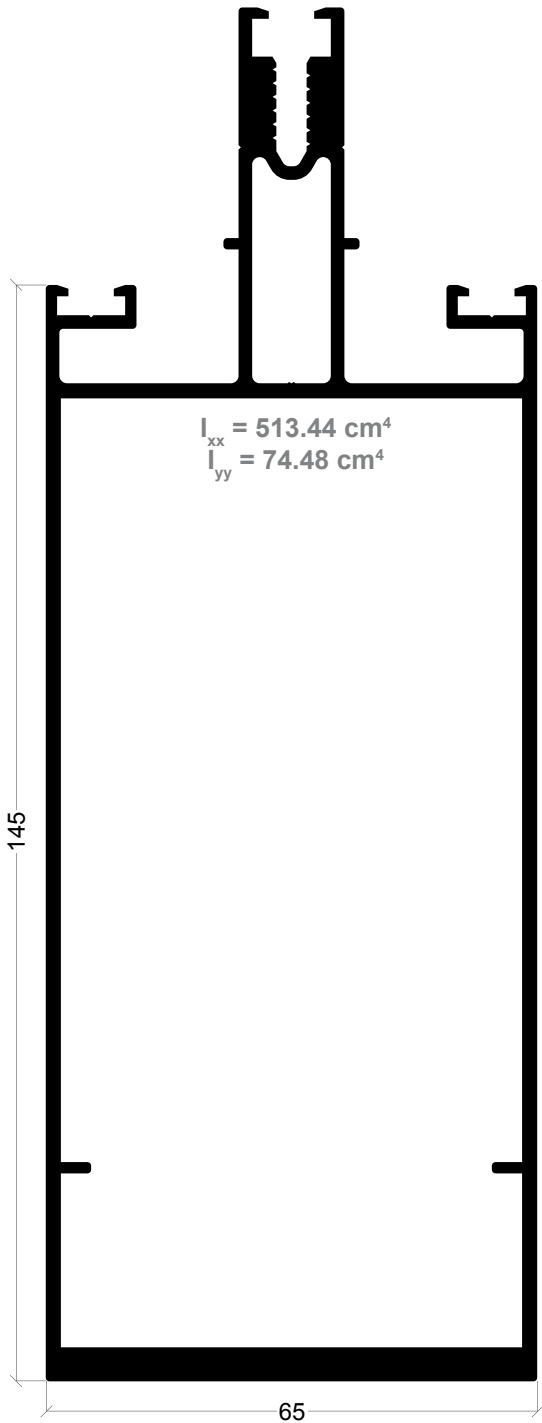

FL-11
Montant de 145 mm

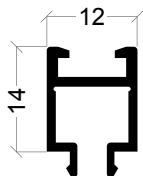

FL-32
Supplément

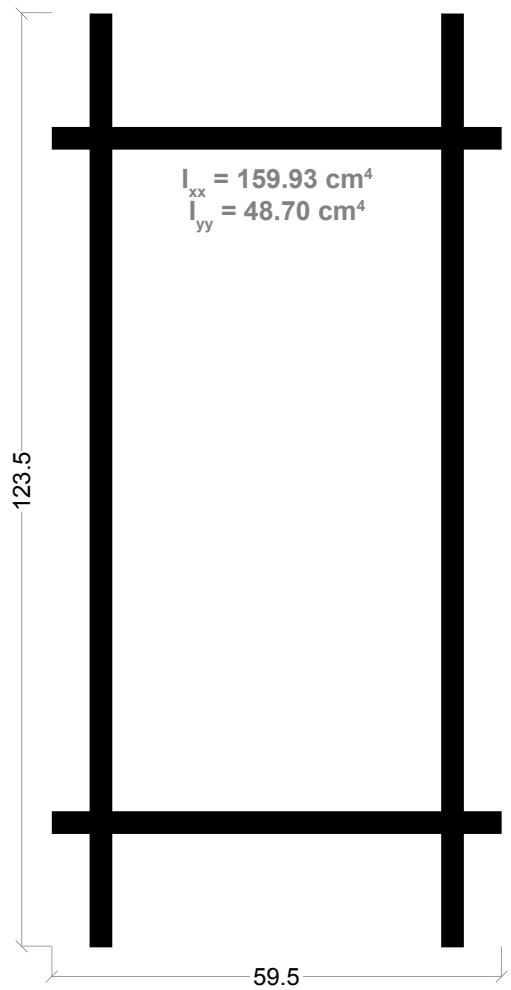

FL-20
Union de montants

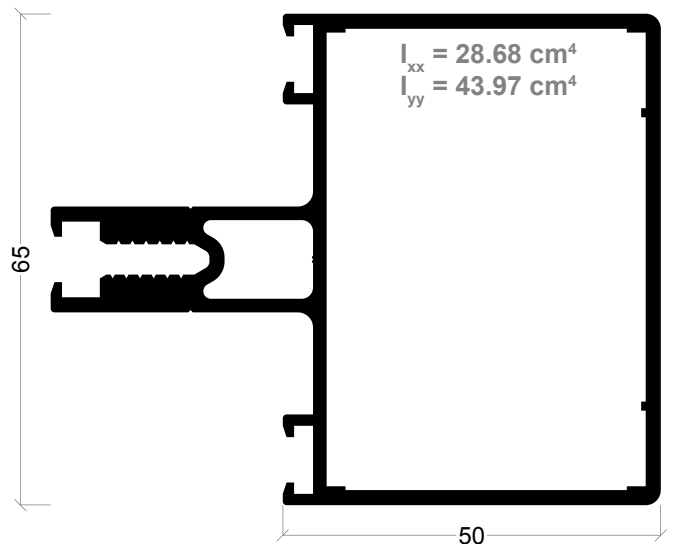

FL-12
Traverse 50 mm

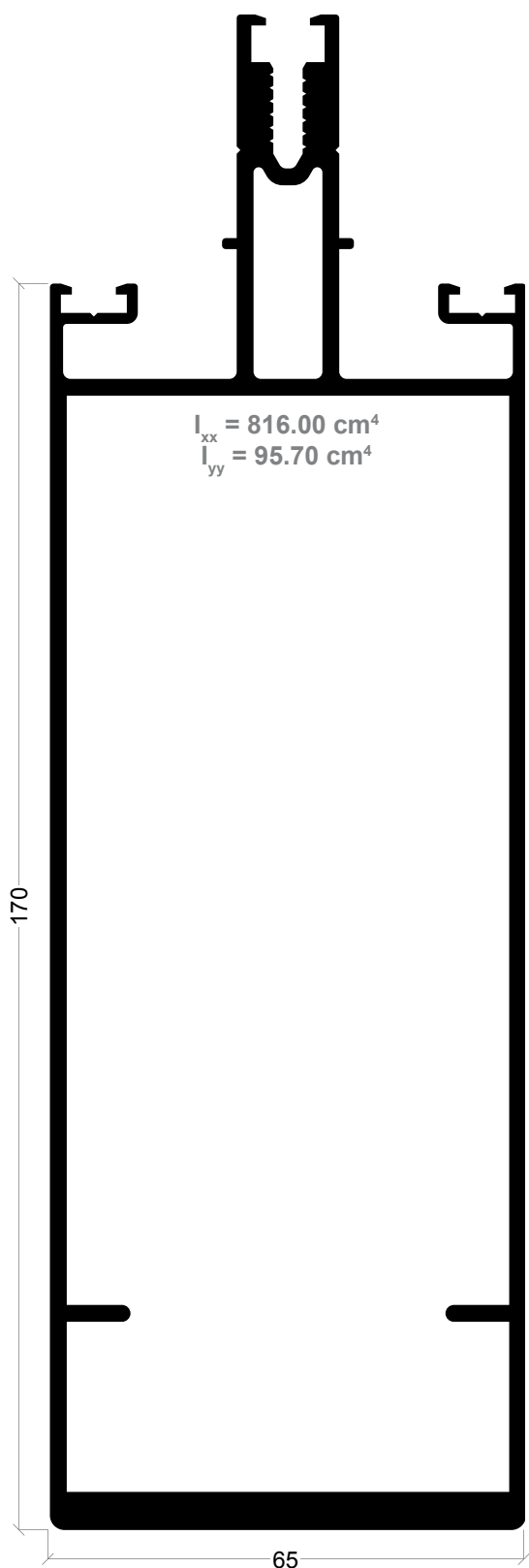

FL-70
Montant de 170 mm

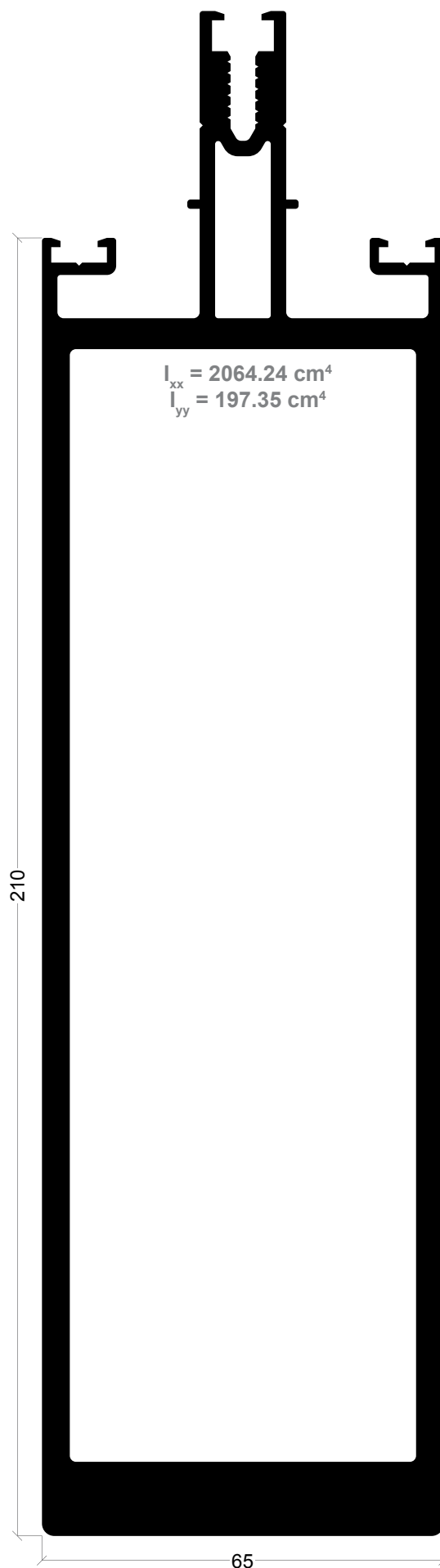

FL-34
Montant de 210 mm

384

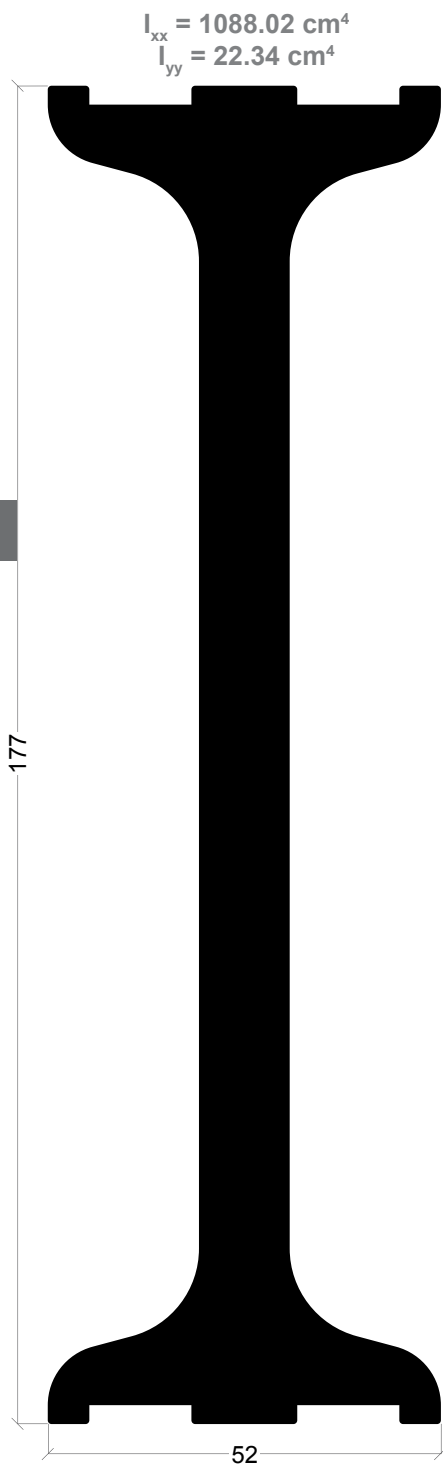

FL-40
IPN de renforcement

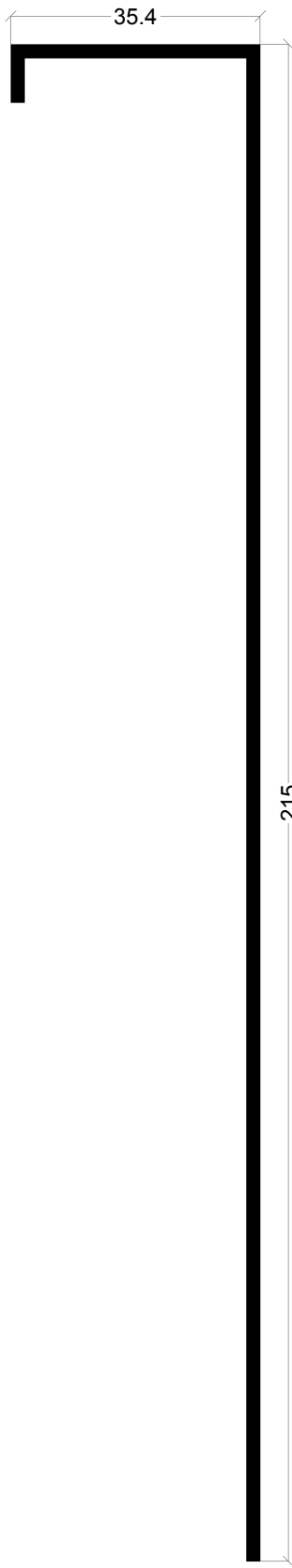

FL-21
Finition

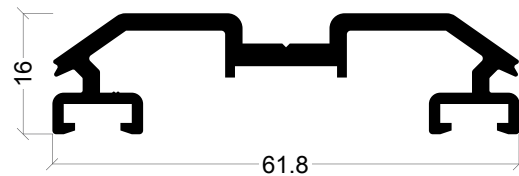

FL-07
Profil avant bouchon

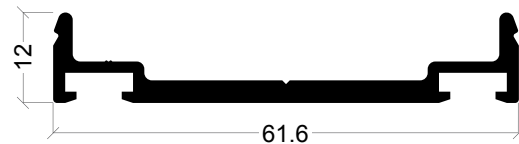

FL-35
Profil avant bouchon

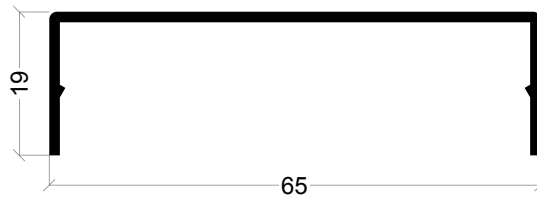

FL-08
Bouchon horizontale

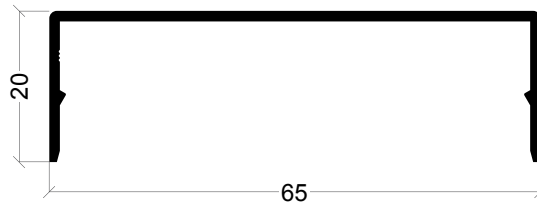

FL-09
Bouchon verticale

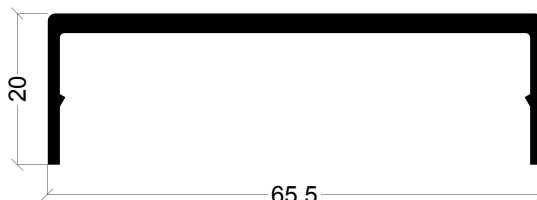

FL-33
Bouchon verticale

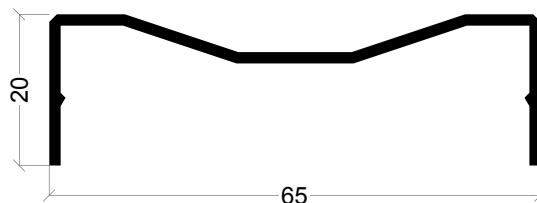

FL-36
bouchon verticale

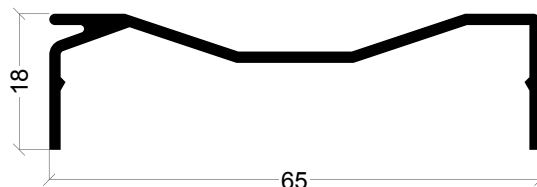

FL-37
Bouchon horizontale

FL-05

Montant 60 mm réglable

FL-04

Montant 60 mm réglable

$I_{xx} = 109.40 \text{ cm}^4$
 $I_{yy} = 23.59 \text{ cm}^4$

$I_{xx} = 108.12 \text{ cm}^4$
 $I_{yy} = 21.88 \text{ cm}^4$

$I_{xx} = 403.77 \text{ cm}^4$
 $I_{yy} = 52.46 \text{ cm}^4$

$I_{xx} = 396.38 \text{ cm}^4$
 $I_{yy} = 49.25 \text{ cm}^4$

FL-30

Montant 120 mm réglable

FL-31

Montant 120 mm réglable

120

40

120

40

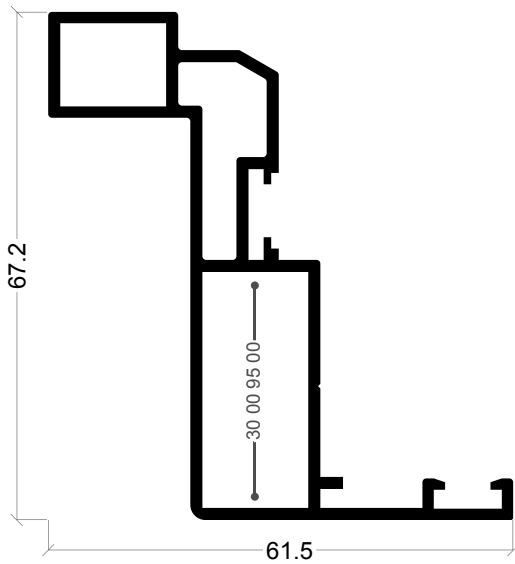

FL-25
Dormant italienne

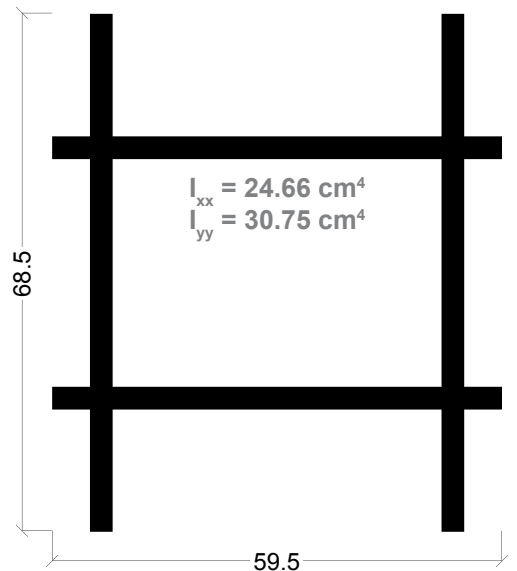

FL-38
Union de montants

103.95

FL-19
Coin

103.95

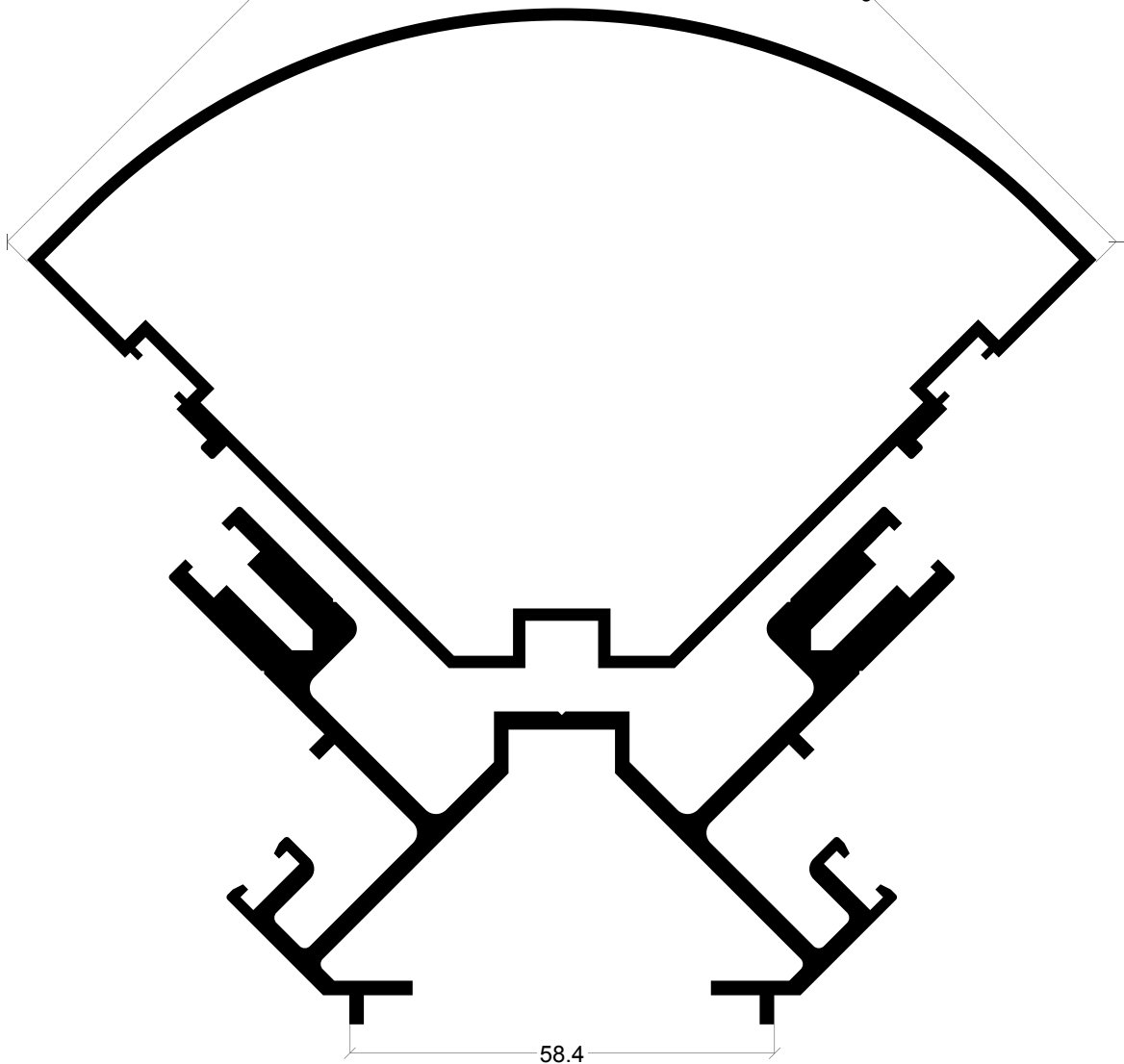

FL-18
Fixateur d'angle

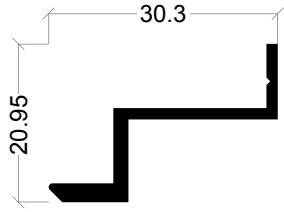

FL-39
Profil de sécurité

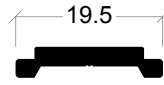

AX-19
Tringel

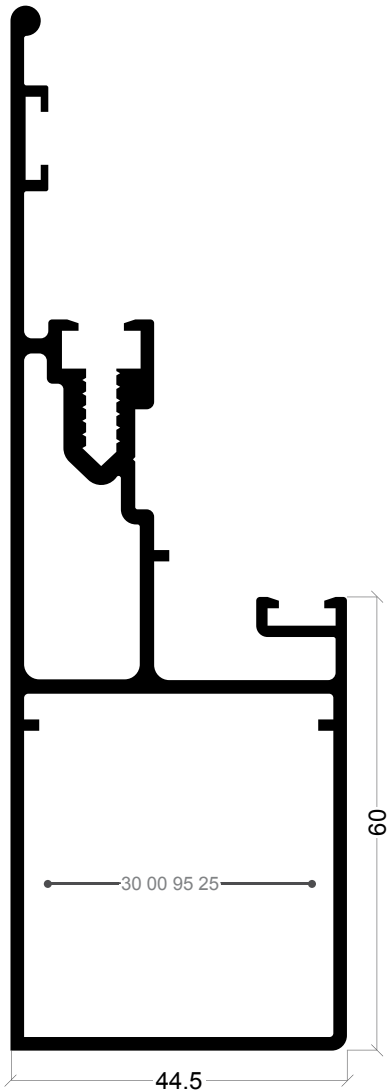

FL-17
Montant finition 60 mm

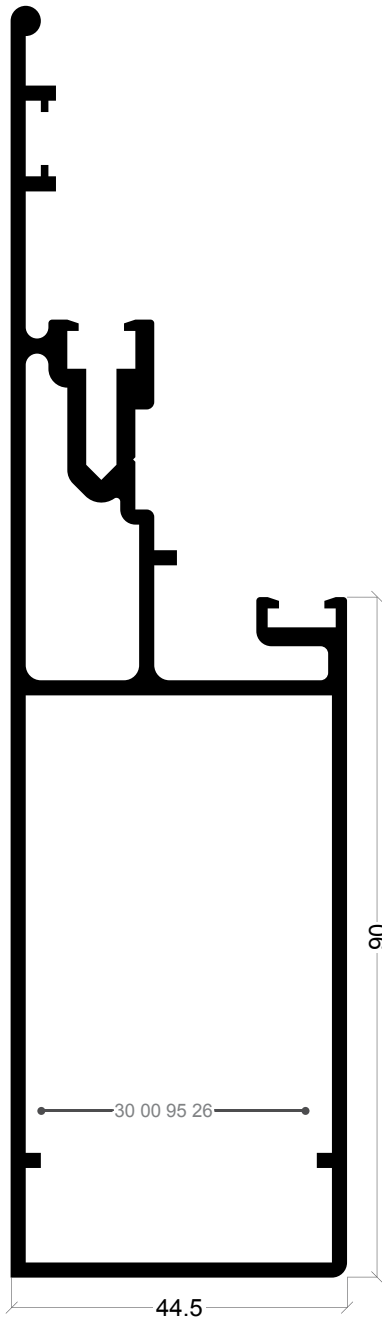

FL-77
Montant finition 90 mm

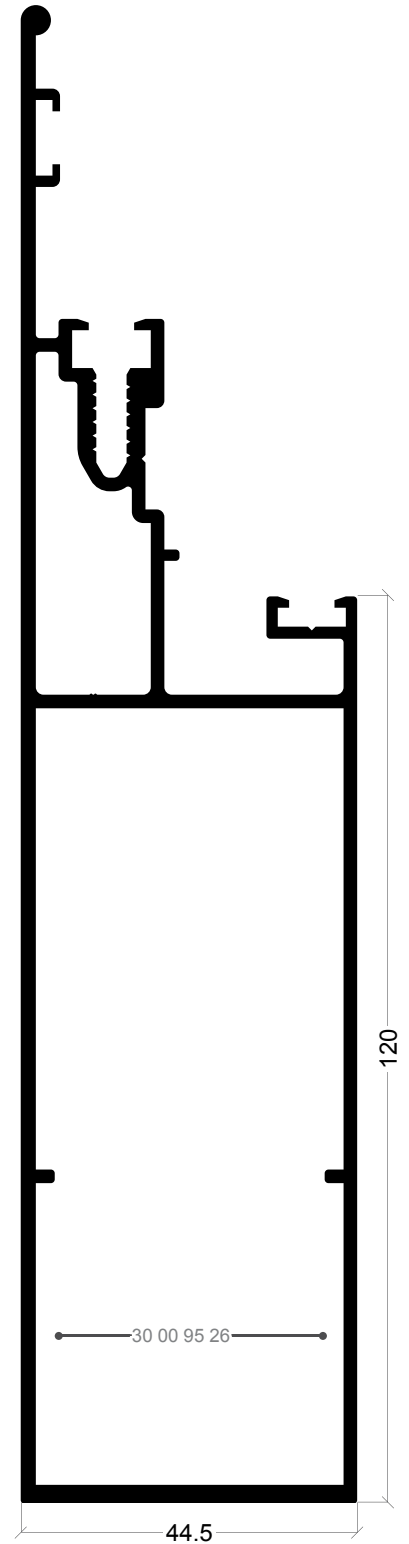

FL-16
Montant finition 120 mm

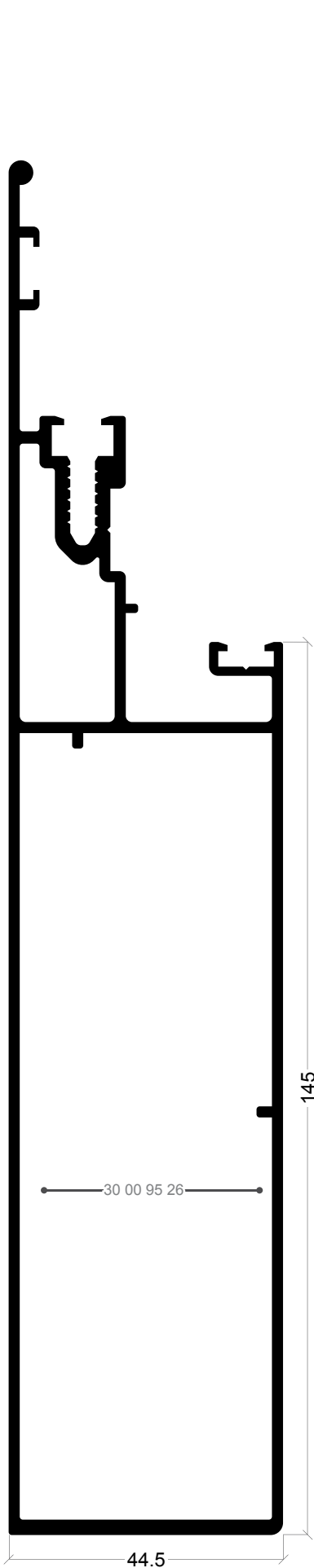

FL-15

Montant finition 140 mm

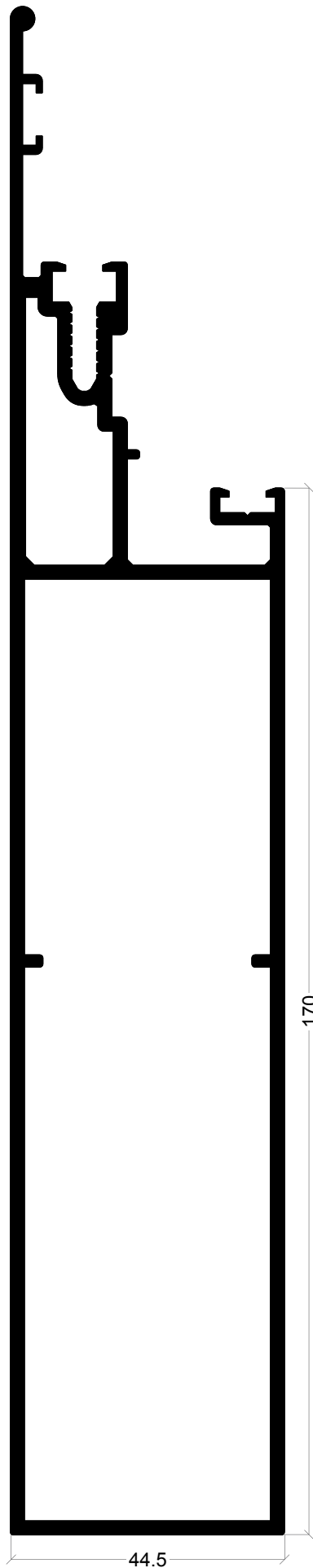

FL-79

Montant finition 170 mm

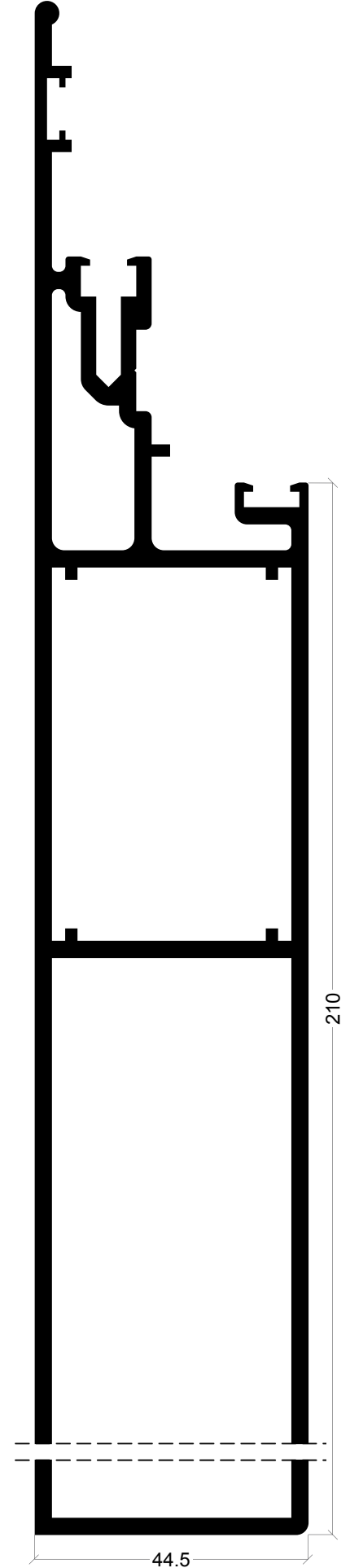

FL-78

Montant finition 210 mm

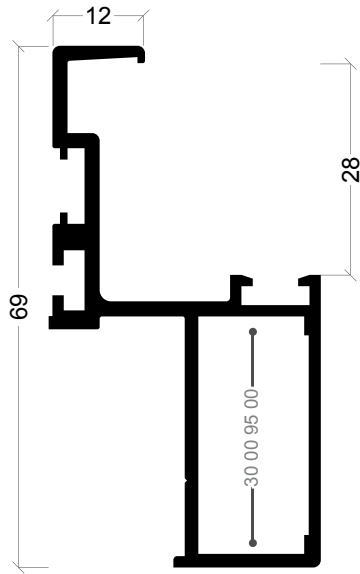

FL-03
Ouvrant demi-structurelle

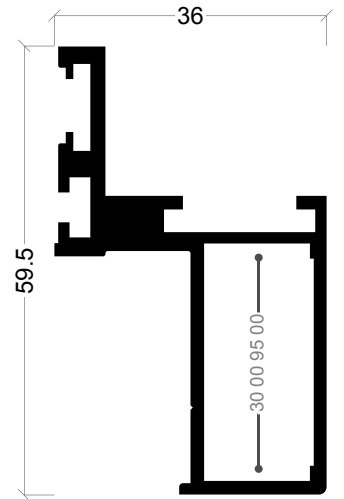

FL-06
Ouvrant structurelle

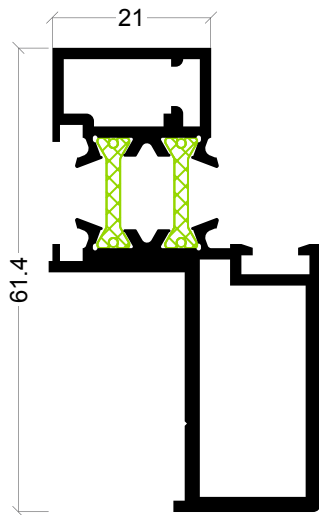

FL-27
Ouvrant structurelle

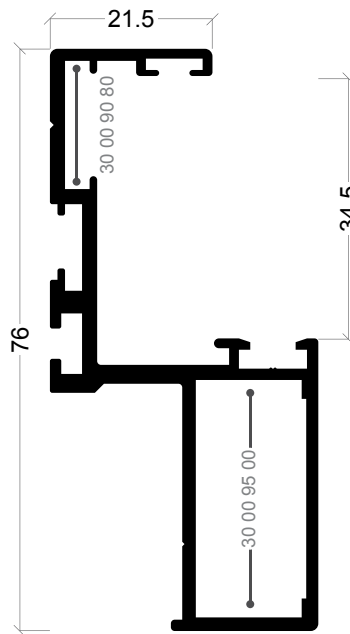

FL-85
Ouvrant demi-structurelle

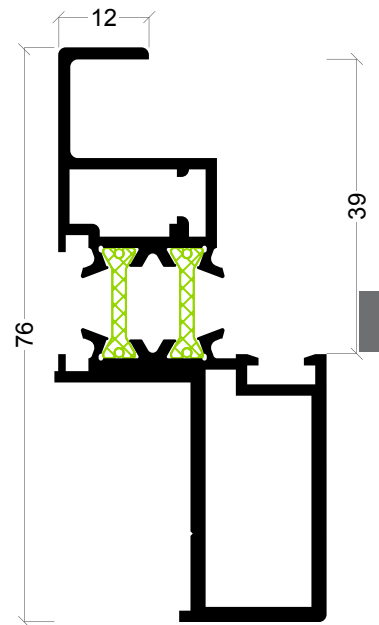

FL-28
Ouvrant demi-structurelle

389

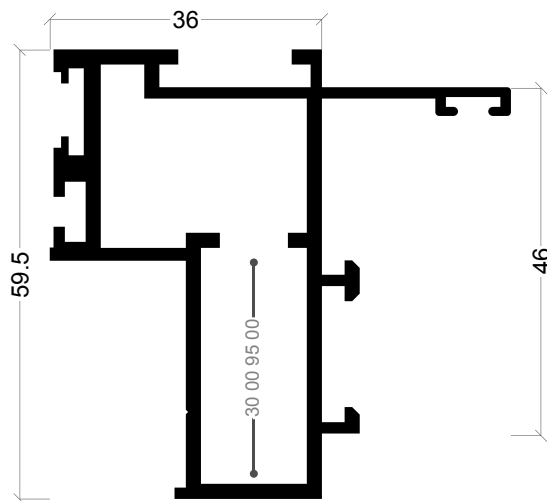

FL-26
Ouvrant structurelle

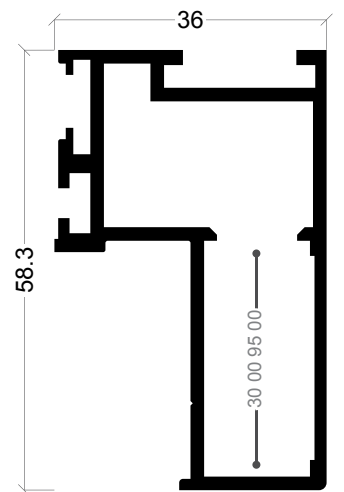

FL-71
Ouvrant structurelle

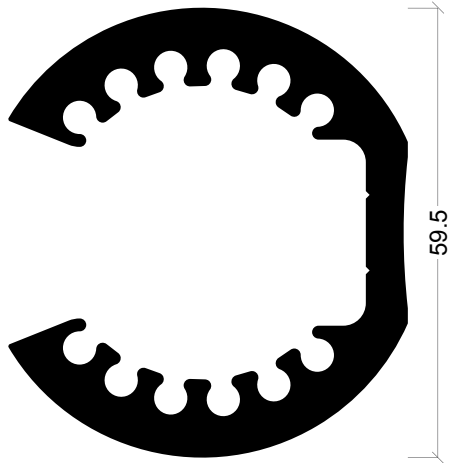

FL-69
Haut de fixation

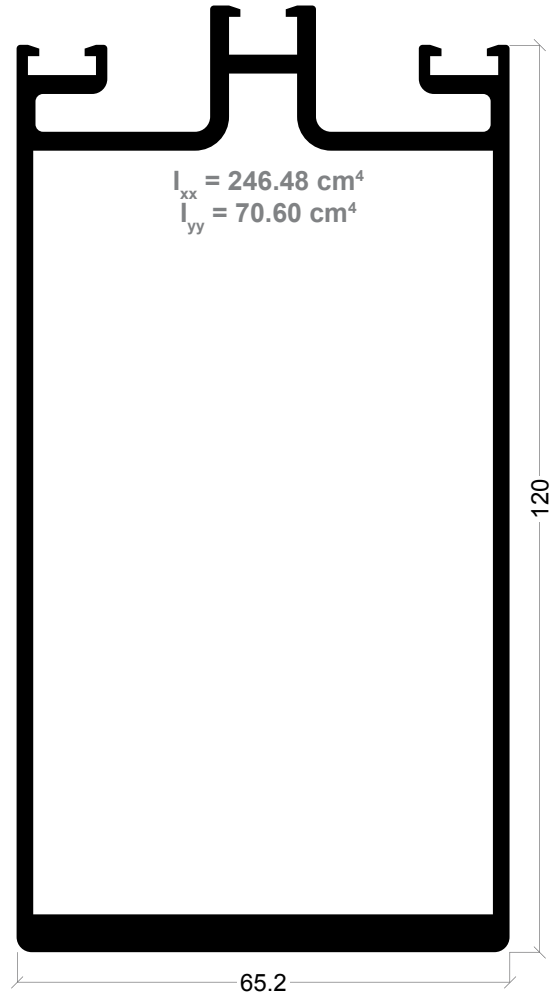

FL-74
Montant 120 mm

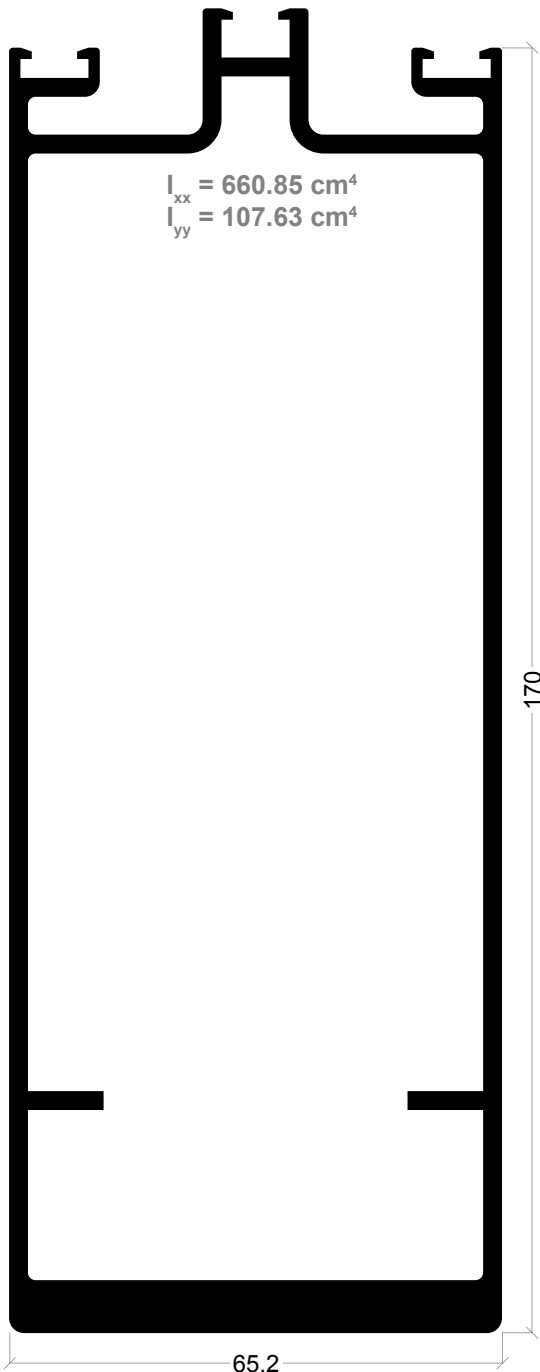

FL-75
Montant 170 mm

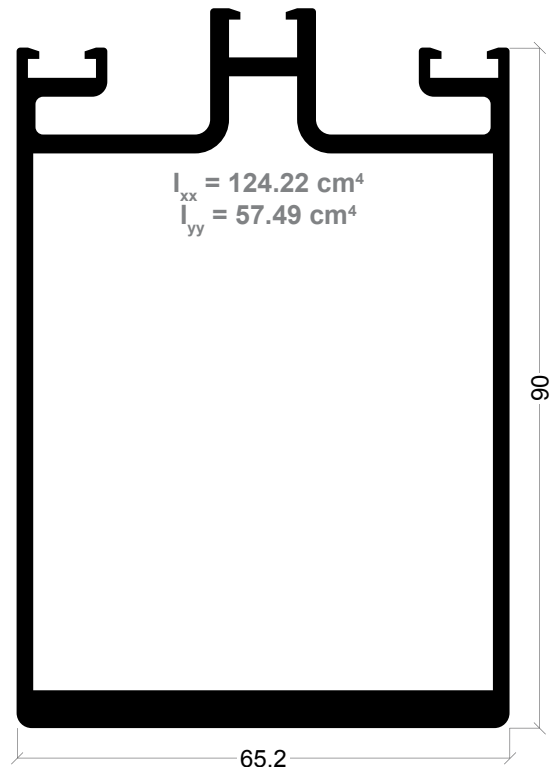

FL-81
Montant 90 mm

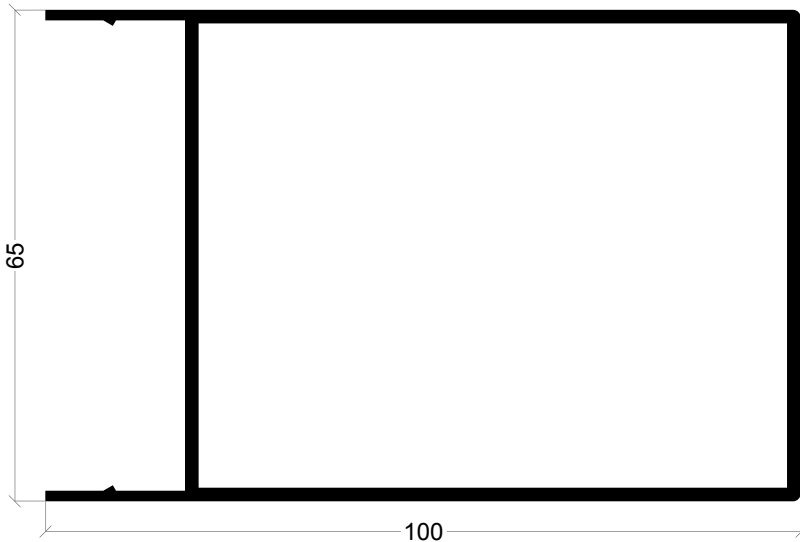

FL-29
Bouchon verticale

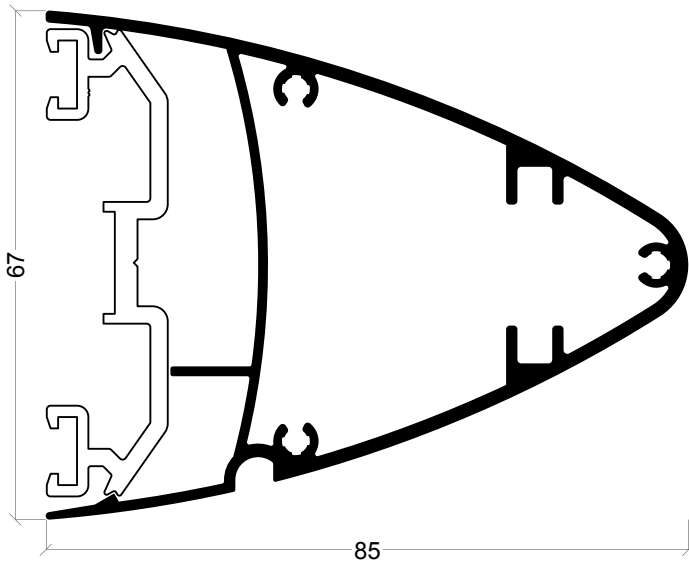

FL-72
Bouchon elliptique 85

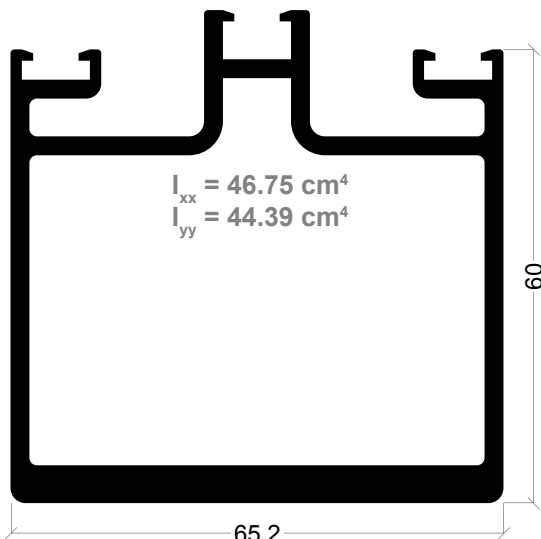

FL-73
Montant 60 mm

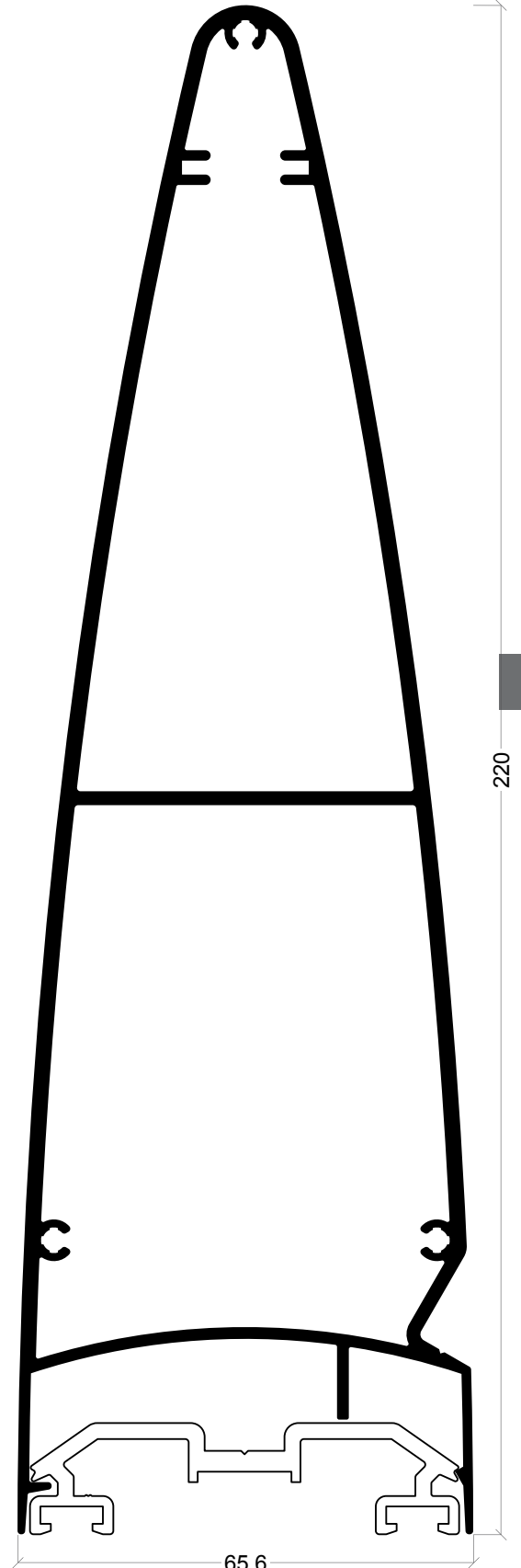

FL-82
Bouchon elliptique 220 mm

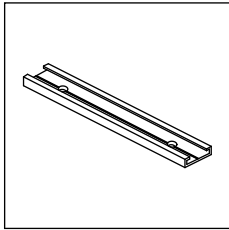

30 00 90 61

Guide fixation latéral

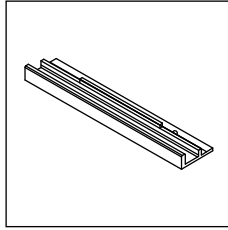

30 00 90 62

Fixation latéral montant

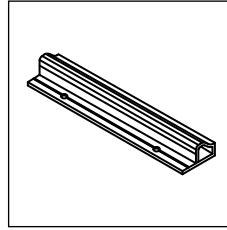

30 00 90 63

Fixation inférieur

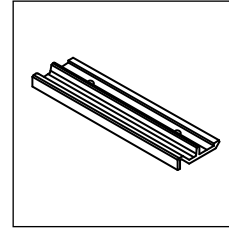

30 00 90 64

Fixation inférieur traverse

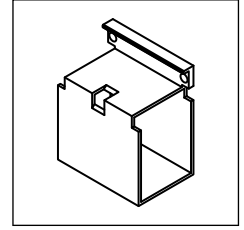

30 00 90 66

Haut traverses / montant traverses

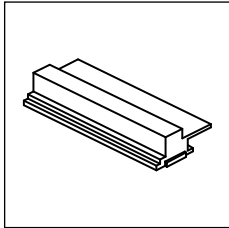

30 00 90 67

Fixation latéral ouvrant

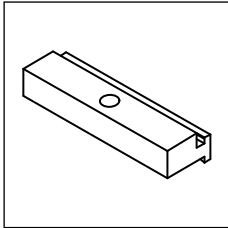

30 00 90 70

Fixation frontal

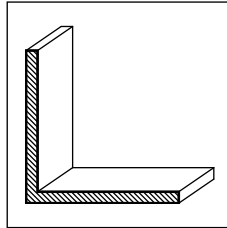

30 00 90 80

Coin de renforcement

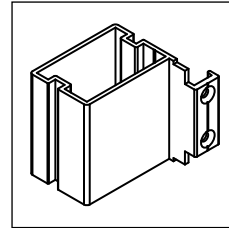

30 00 94 98

Union façade montant / montant avec boulons

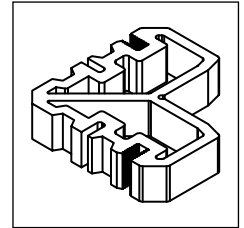

30 00 94 99

Equerre de coin 13.7 x 31.6 mm

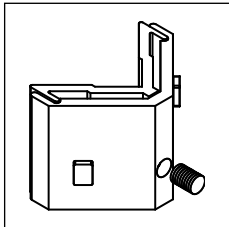

30 00 95 00

Equerre ouvrant

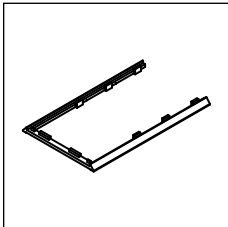

30 00 95 16

Joint de étanchéité union montants

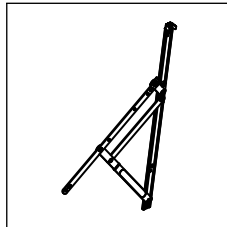

30 00 95 20

Jeux compas façade (120 kg)

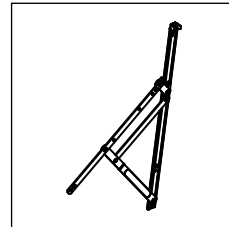

30 00 95 21

Jeux compas façade (180 kg)

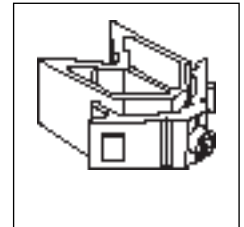

30 00 95 25

Equerre 40x41 centré (FL-17)

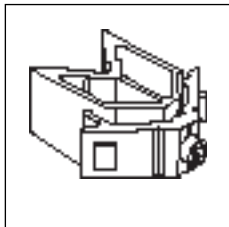

30 00 95 26

Equerre 61x41 centré (FL-15,16,77)

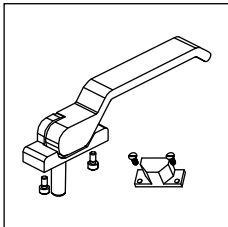

30 00 95 31/41

Kit poignée droit/gauche noir

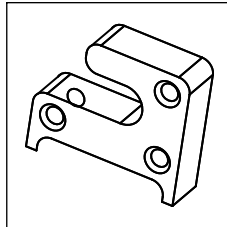

30 00 95 70

Pièce fixation d'ouvrant

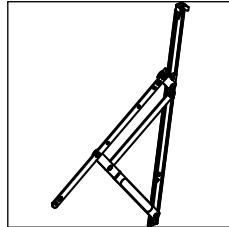

30 00 95 71

Jeux compas façade (60 kg)

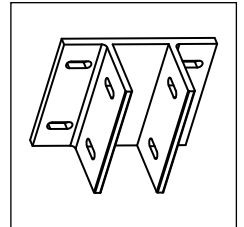

31 00 90 65

Fixateur montant

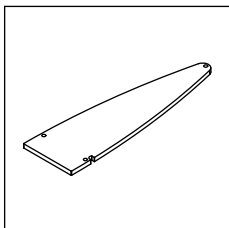

31 00 95 73

Bouchon elliptique 220 mm

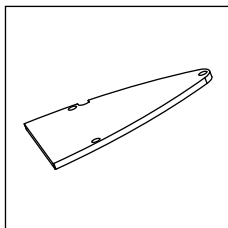

31 23 90 97

Bouchon elliptique 85 mm

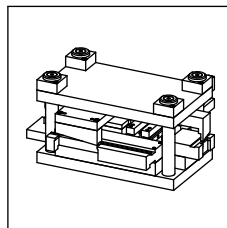





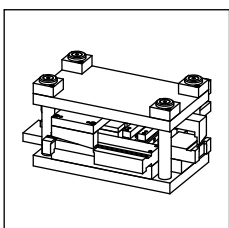









33 97 79 99

Outil FL



33 97 81 99

Outil FL Intercalaire (profils FL-15/16/17/77)

Référence	Dessin	Description
30 00 95 01	 11	Joint intérieur montant Joint central montant et traverse (mur rideau)
30 00 95 02		Joint intérieur montant (fxation latéral dormants)
30 00 95 03		Joint central (montant et traverse) Façade structurelle et demi-structurelle
30 00 95 05	 5	Joint intérieur traverse Joint de dormant (fenêtre caché en mur rideau)
30 00 95 06	 7	Joint central montant et traverse
30 00 95 07	 13	Joint central montant et traverse
30 00 95 08	 15	Joint central montant et traverse (selon verre)
30 00 95 09		Joint d'étanchéité montant FL-11
30 00 95 10		Joint d'étanchéité traverse FL-12
30 00 95 13		Joint ouvrant de rupture thermique
30 00 95 76	 9	Joint central montant et traverse
30 20 26 03		Joint extérieur Joint intérieur Joint d'étanchéité
30 90 20 80		Joint extérieur pour système Ergolux
30 99 95 11		Joint d'ouvrant assemblage extérieur Joint montant de finition Joint d'ouvrant et dormant (fenêtre caché en mur rideau)

Détail de fixation du montant

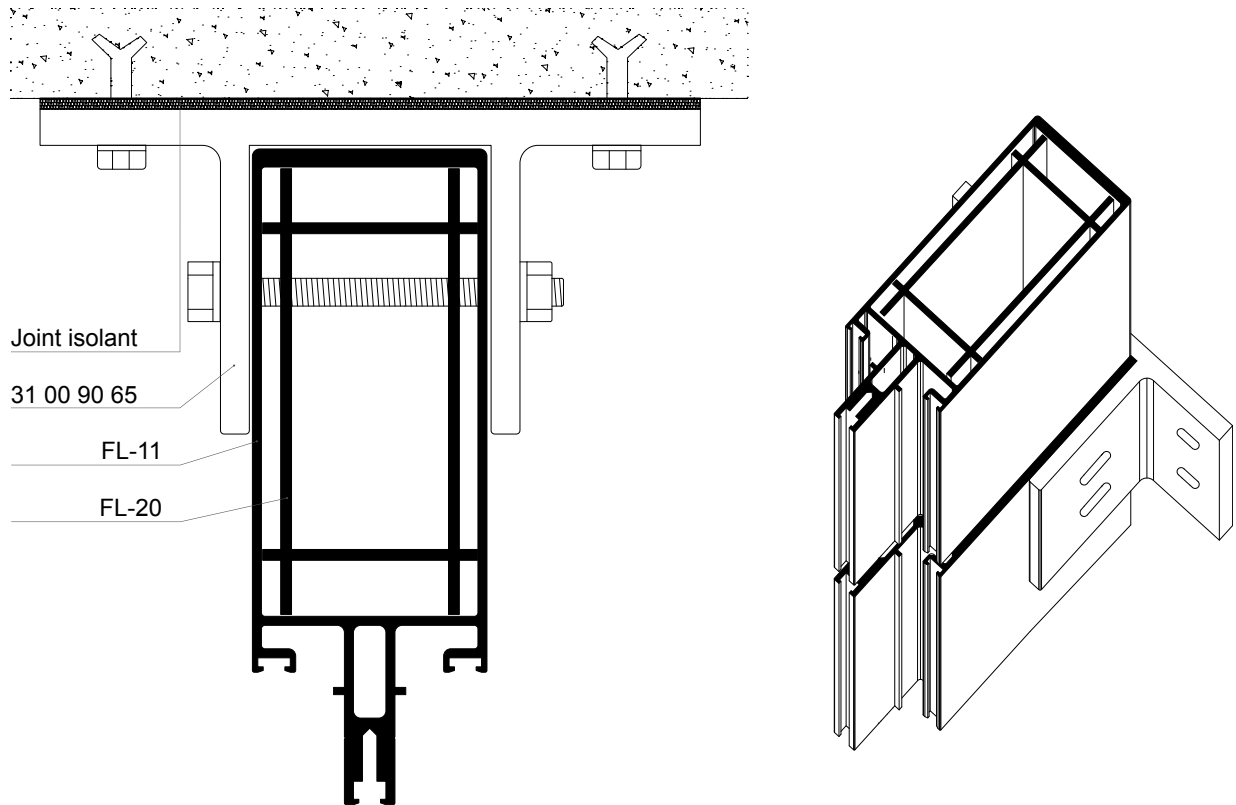

394

Union montant traverse

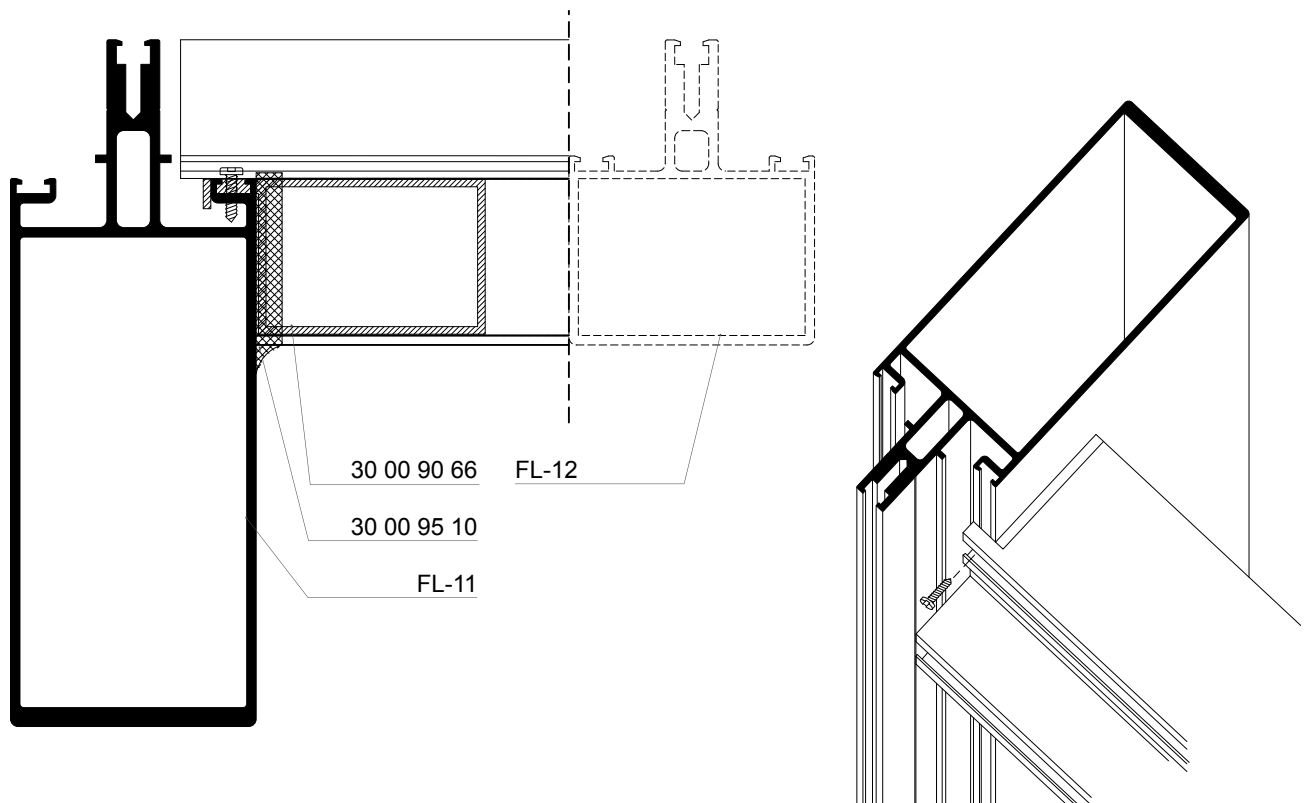

Mésures de coupe de la traverse

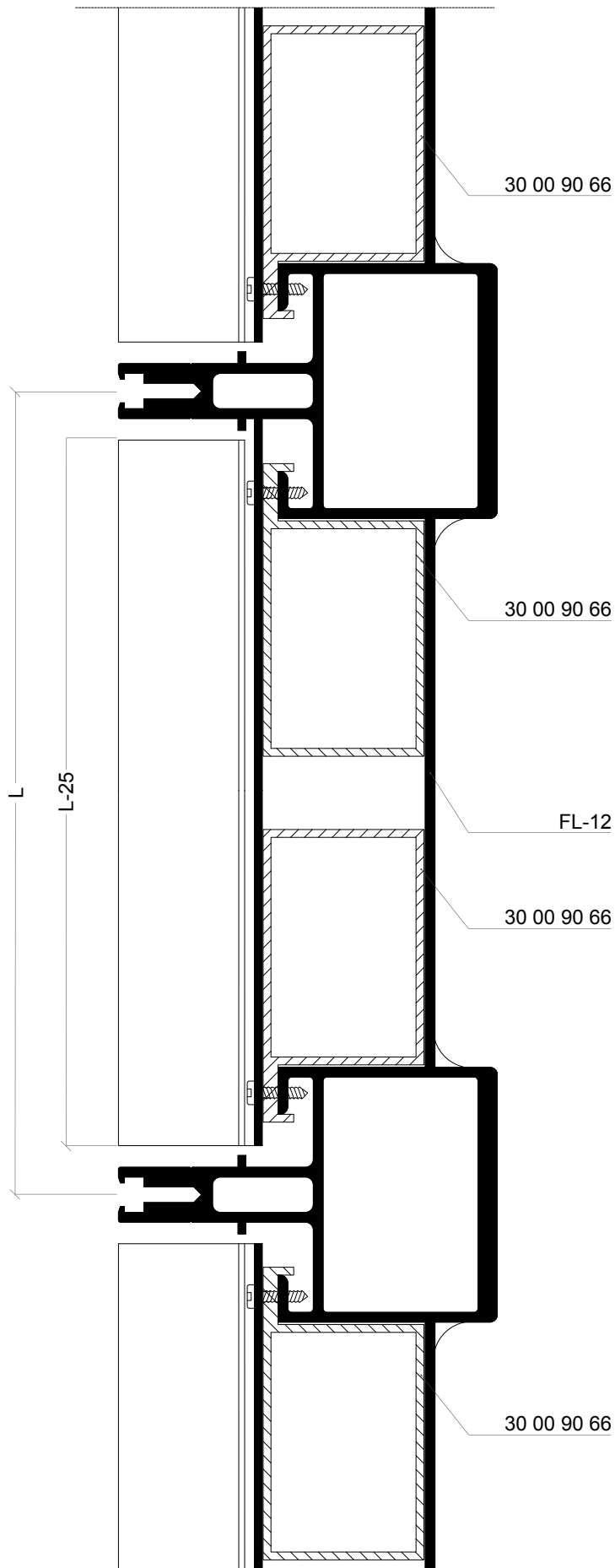

Mesures de coupe façade structurelle et demi-structurelle

Détail horizontale et verticale système de fixation frontal

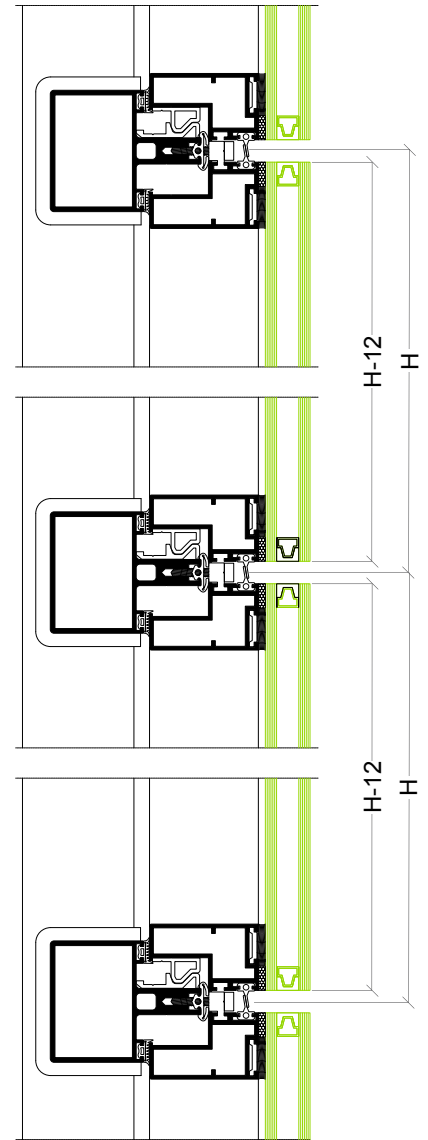
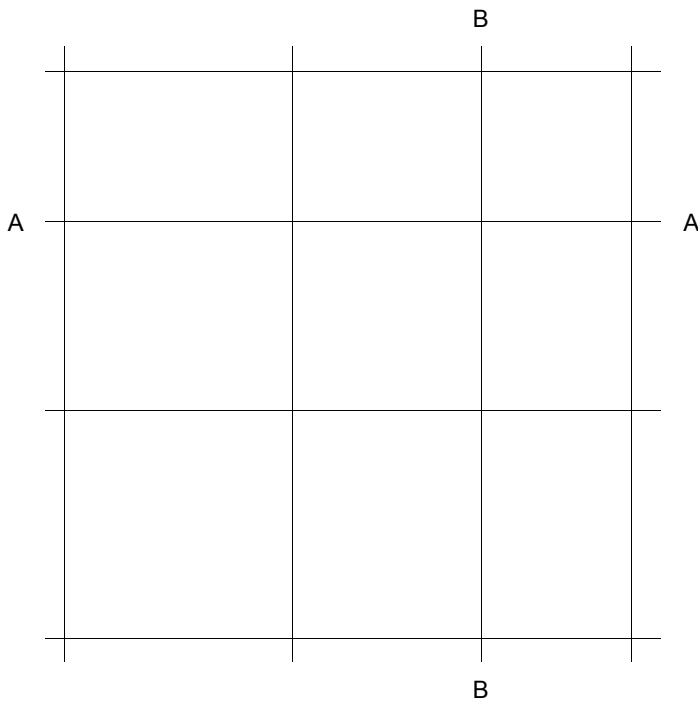

Section A-A

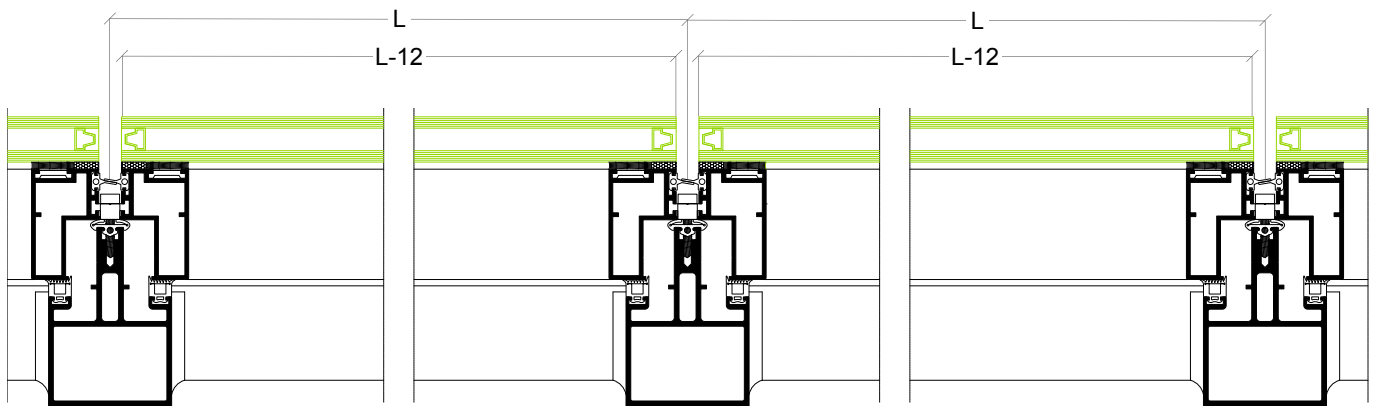

Section B-B

Assemblage de vantail fixe

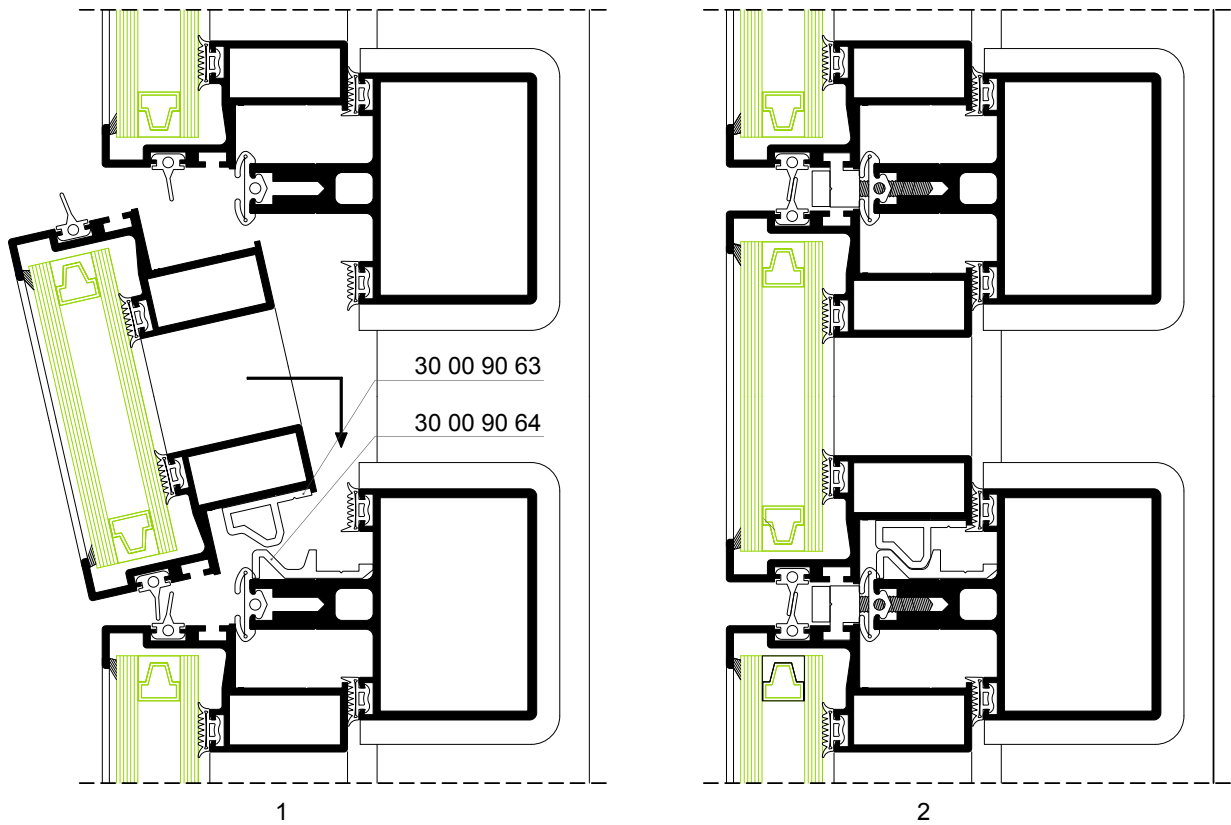

Assemblage de vantail fixe

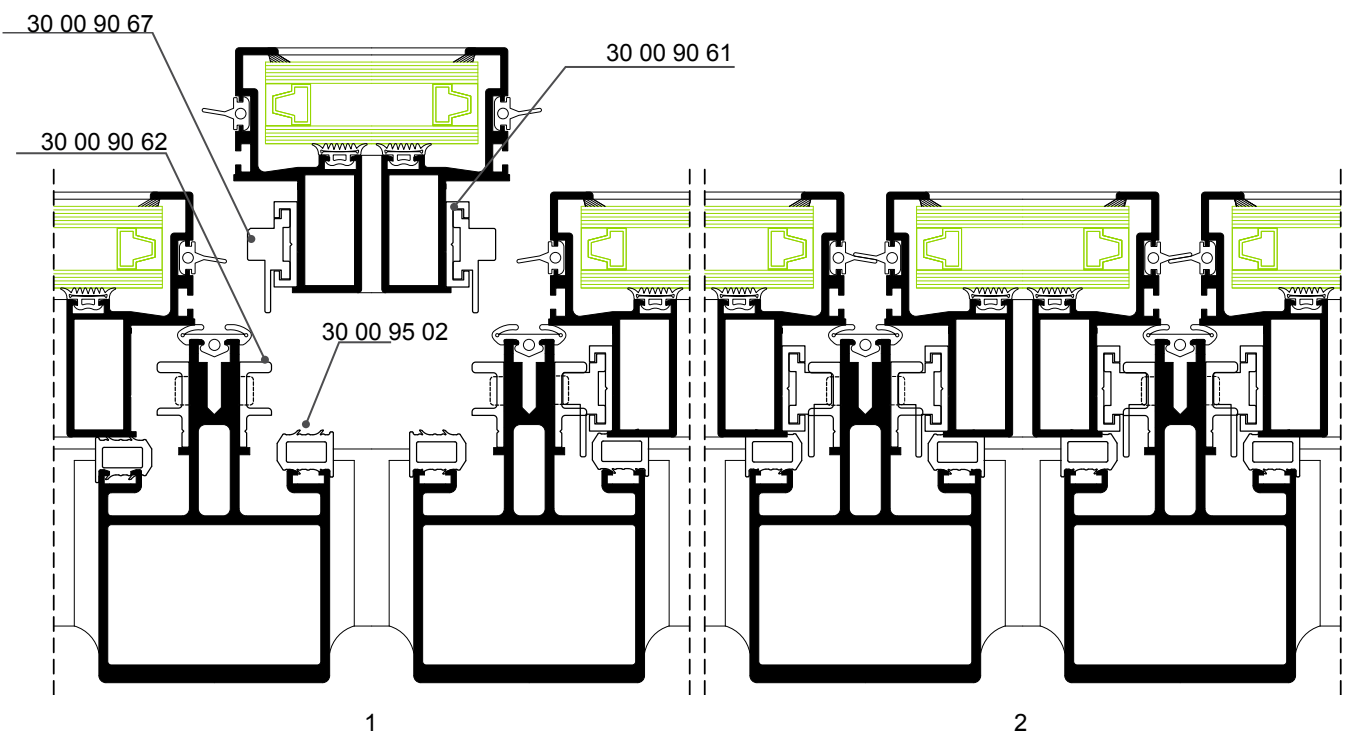

Façade structurale et demi-structurale Système de fixation de vantaux fixes

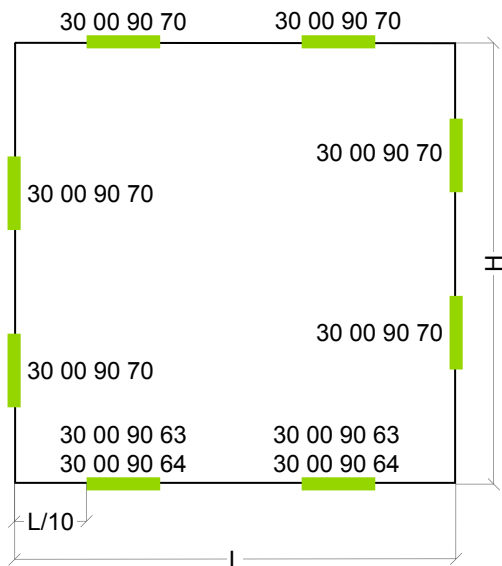

Vantail fixe Système de fixation frontal

Pièce de fixation	L	H	N° de pièces	
			L	H
30 00 90 70	jusqu'à 1000 mm	jusqu'à 1000 mm	2	2
	chaque 500 mm	chaque 500 mm	1	1

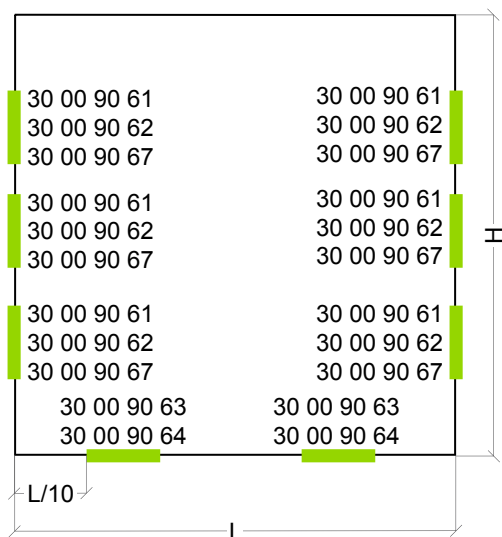

Vantail fixe Système de fixation intérieur latéral

Pièce de fixation	L	H	N° de pièces	
			L	H
30 00 90 61 30 00 90 62 30 00 90 67	jusqu'à 1000 mm	jusqu'à 1000 mm	-	3
	chaque 500 mm	chaque 500 mm	-	1
30 00 90 63 30 00 90 64	jusqu'à 1000 mm	jusqu'à 1000 mm	2	-
	chaque 500 mm	chaque 500 mm	1	-

398

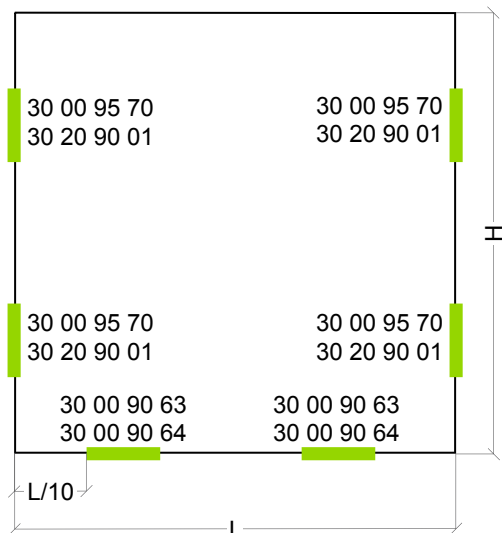

Vantail fixe Système de fixation extérieur latéral

Pièce de fixation	L	H	N° de pièces	
			L	H
30 00 95 70 30 20 90 01	-	-	-	2
	-	-	-	-
30 00 90 63 30 00 90 64	jusqu'à 1000 mm	jusqu'à 1000 mm	2	-
	chaque 500 mm	chaque 500 mm	1	-

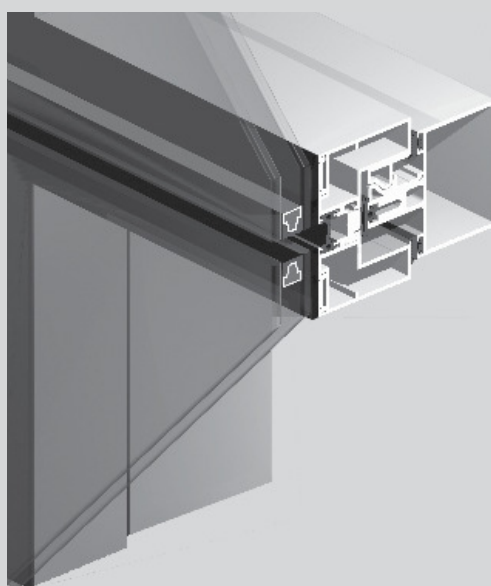
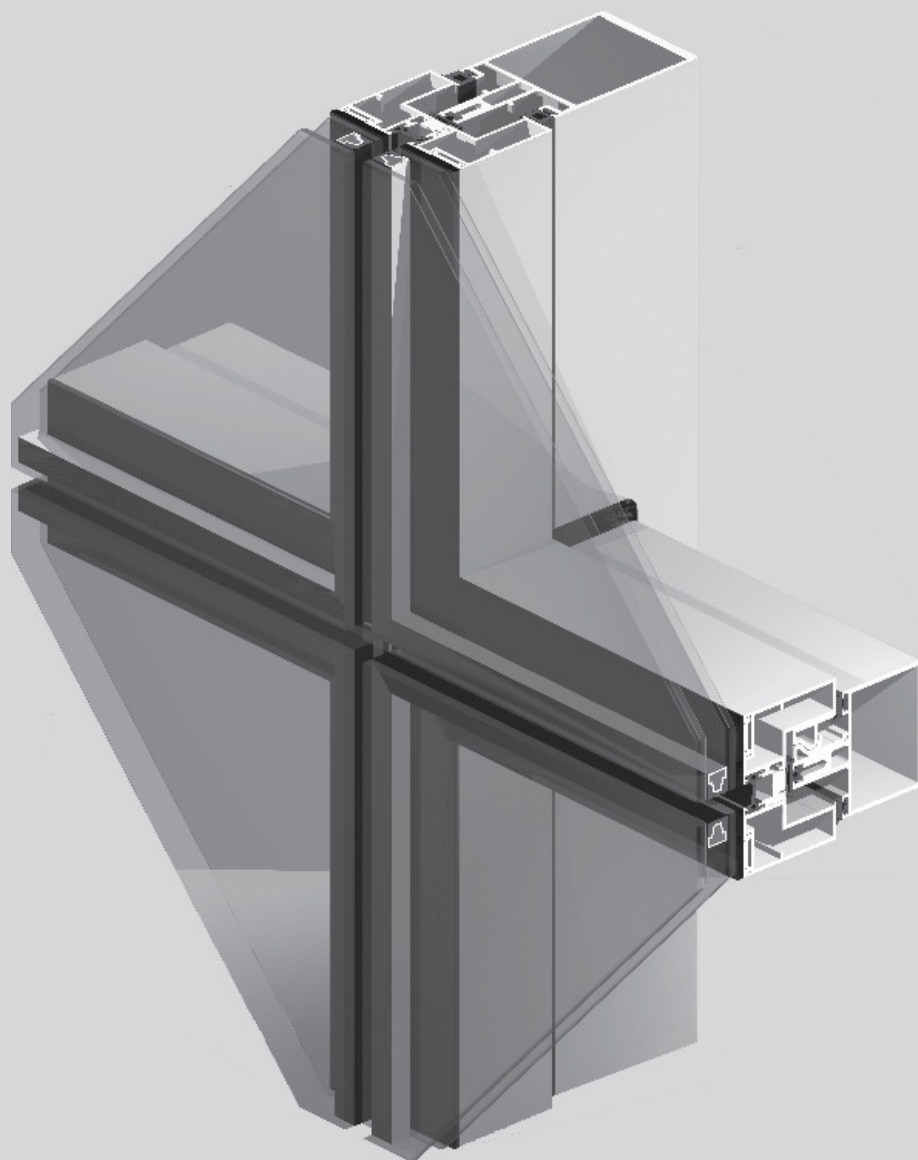

**Façade
Structurelle**

Façade Structurelle

Caractéristiques

Dans ce système le placement de verres est réalisée au moyen de coulisses en qui est placé un profil principalement anodisé pour permettre le collage de silicone structurelle. De cette mode, le verre caché totalement les profils, acquisition de ce type de façade, une vue extérieur juste de verre, fournissant ainsi un effet type VEC - Verre Extérieur Collé.

Le section des montants et traverses c'est 65 mm, visible seulement de intérieur.

Les deux profils présents canaux de drainage et de ventilation qui assurent, jointment avec le système de joints EPDM, une étanchéité et perméabilité maximales. Éventuellement, ils ont un profil spécial de sécurité qui évite l'effort coupante du verre. Possibilité de profils avec rupture thermique.

Finitions

Le bare qui reçoit le verre doit avoir une anodisation spéciale du profil périmétrale ($>20 \mu\text{m}$), nécessaire pour assurer un parfait collage du verre avec silicone structurelle. Le profil restant permet toutes les possibilités de finition: laqué, laqué décorative (bois) ou anodisé.

Possibilités d'ouverture

Ouverture italienne réalisé à travers de compass en axe inox avec une résistance à 180 kg, tellement ouvrants fixes comme l'italiennes sont fabriqués avec le même profil périmétrale, rendant ainsi imperceptible sa distinction par l'extérieur.

Détail horizontale et verticale

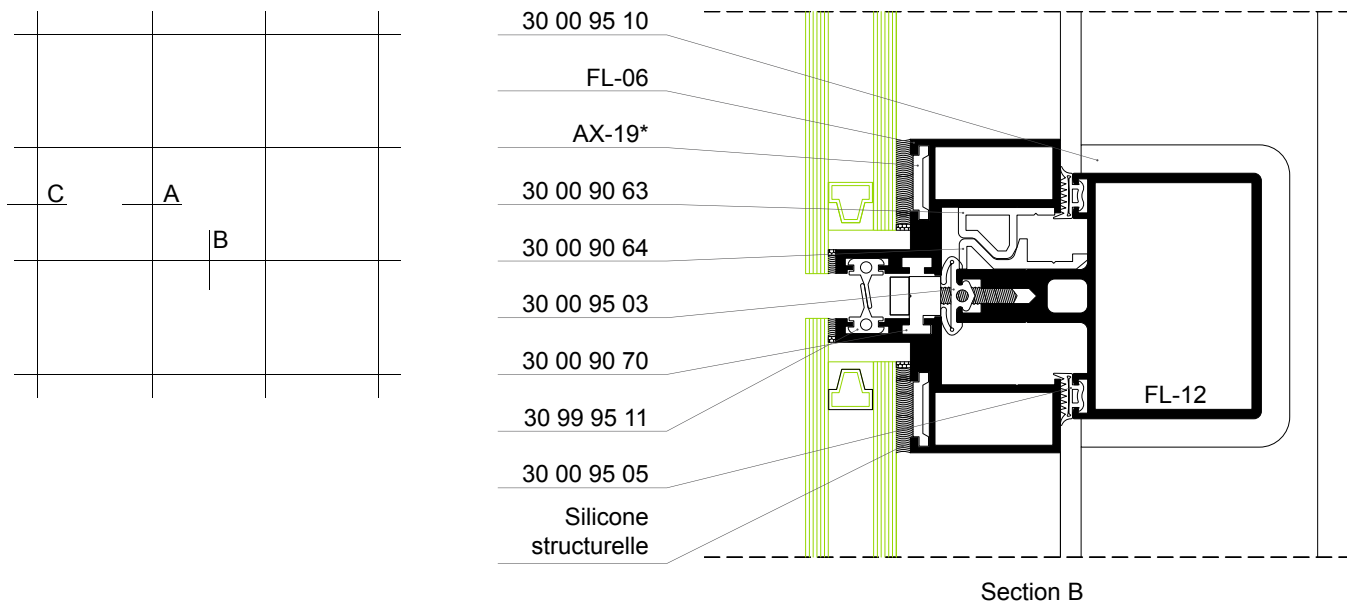

* Profil anodisé avec classe 20, colle spéciale avec silicone structurelle

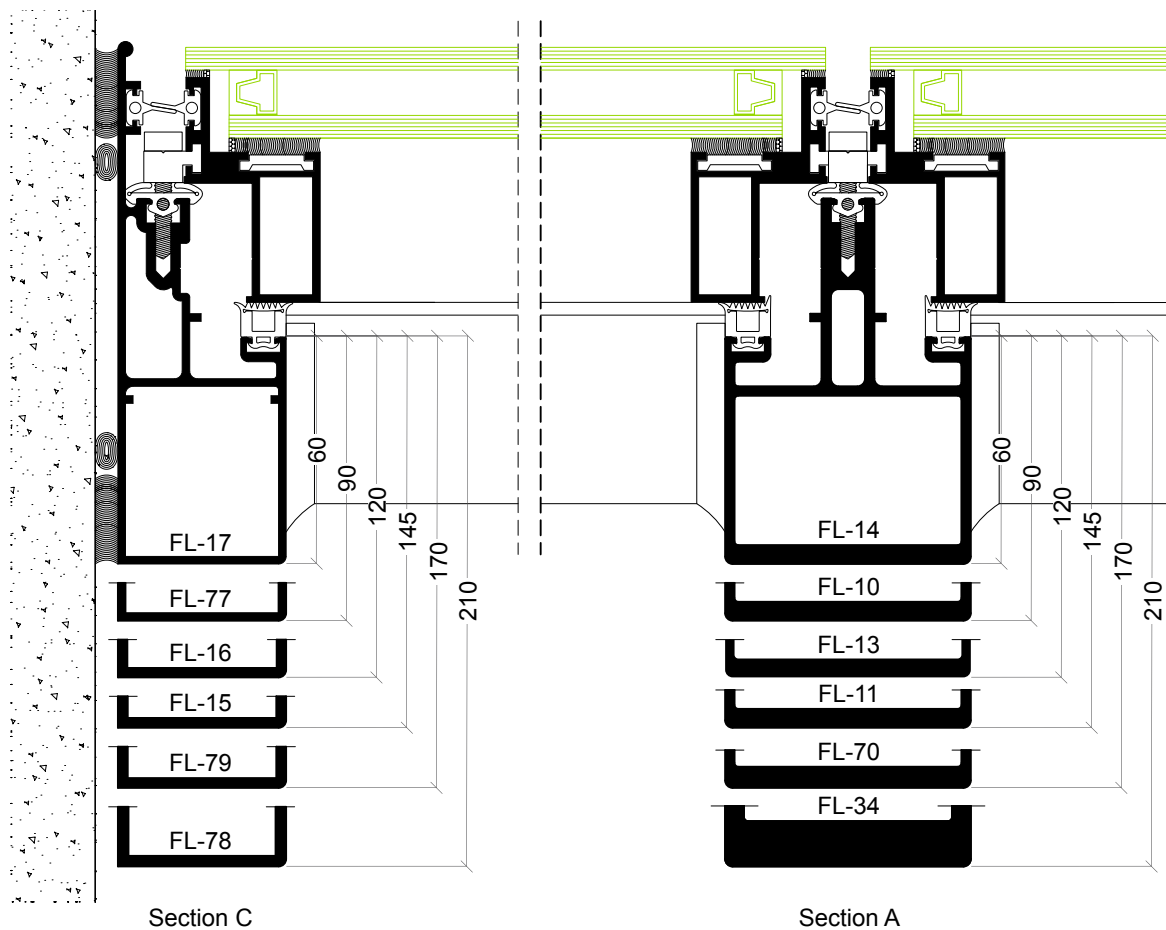

Détail coin 90°

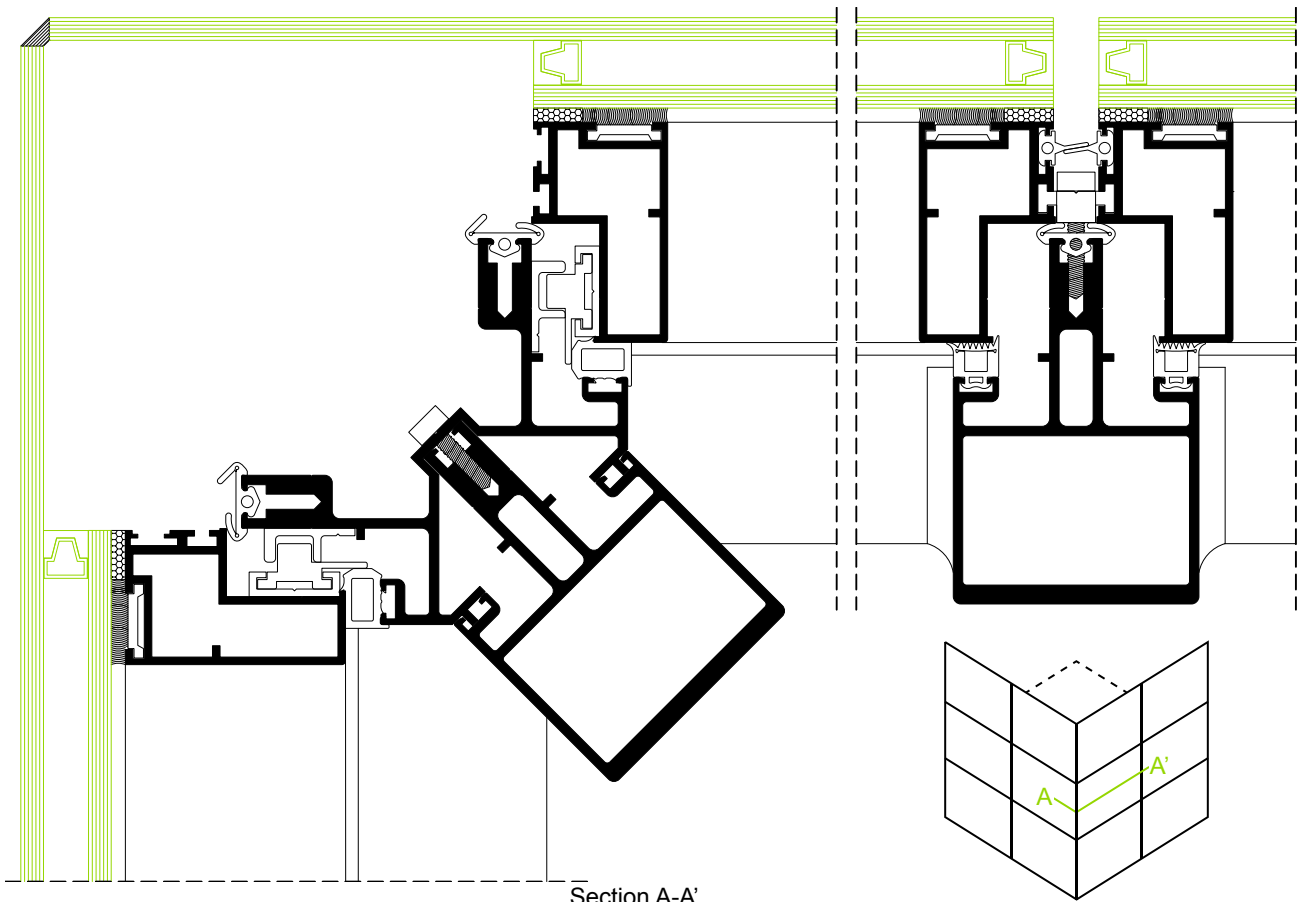

402

Détail coin 90°

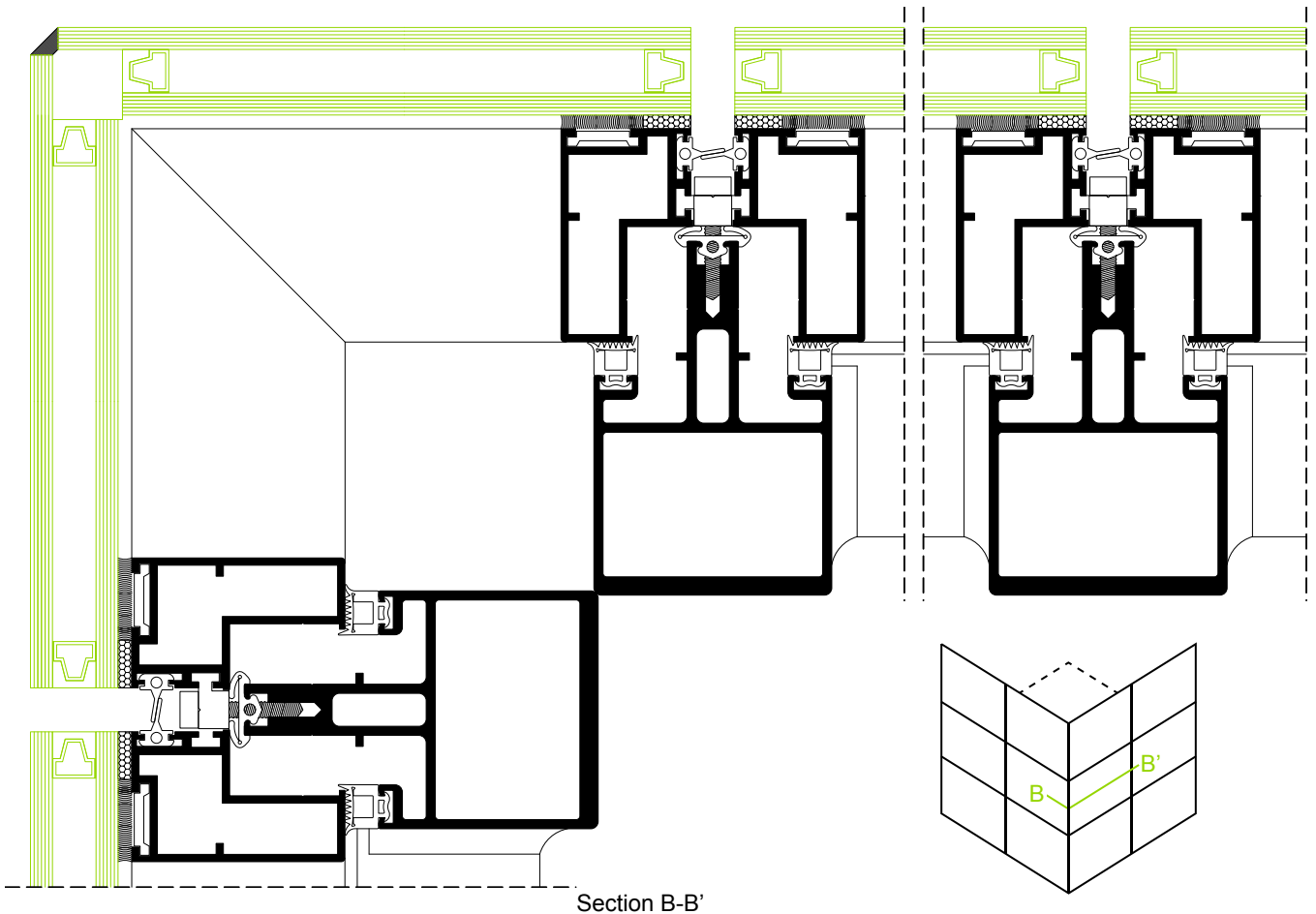

Section B-B'

Détail coin 90°

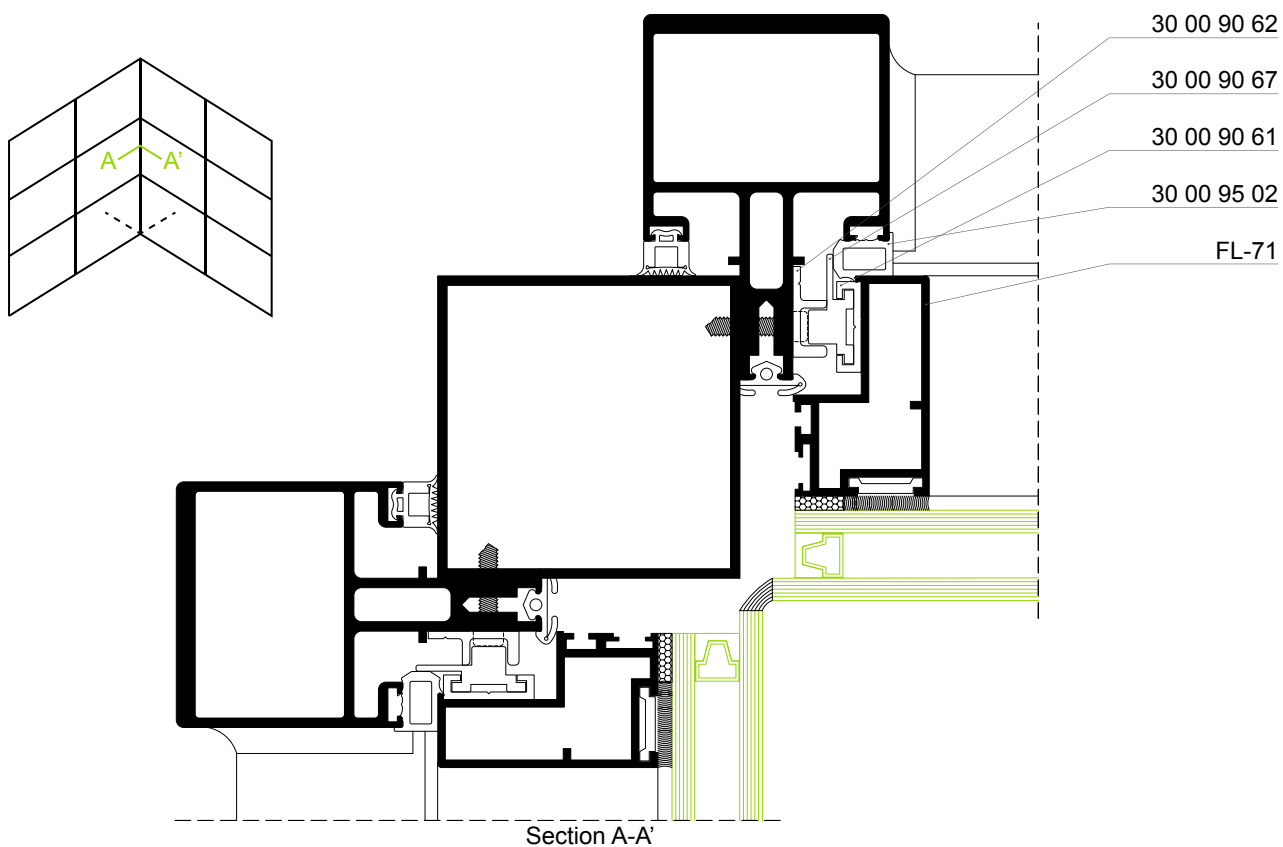

Détail coin variable de 15° a 30°

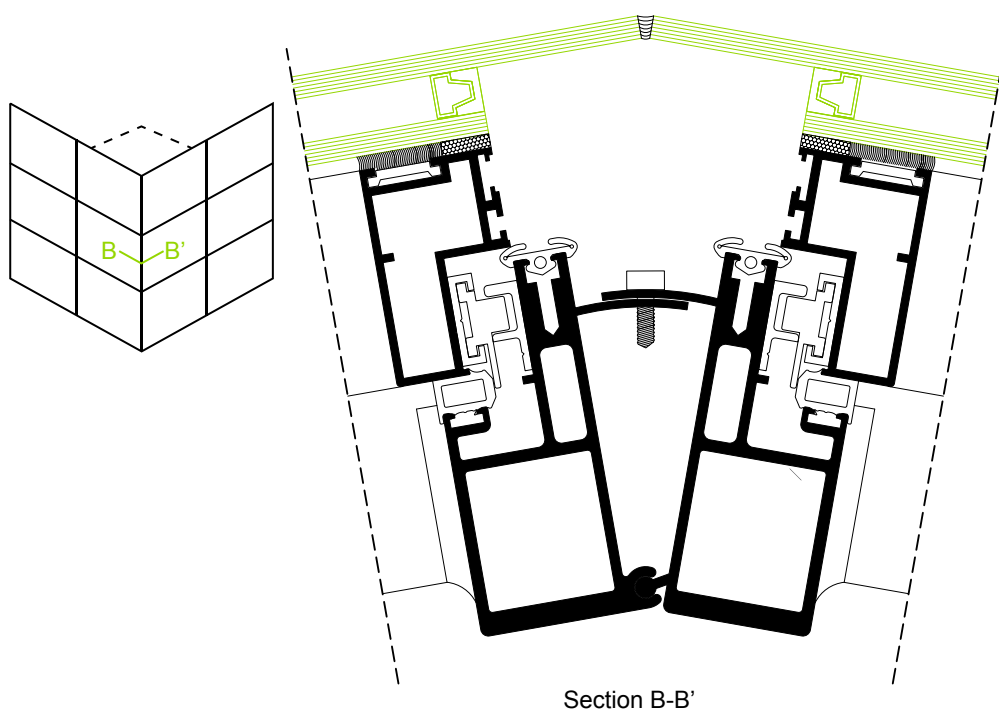

Détail horizontale et verticale

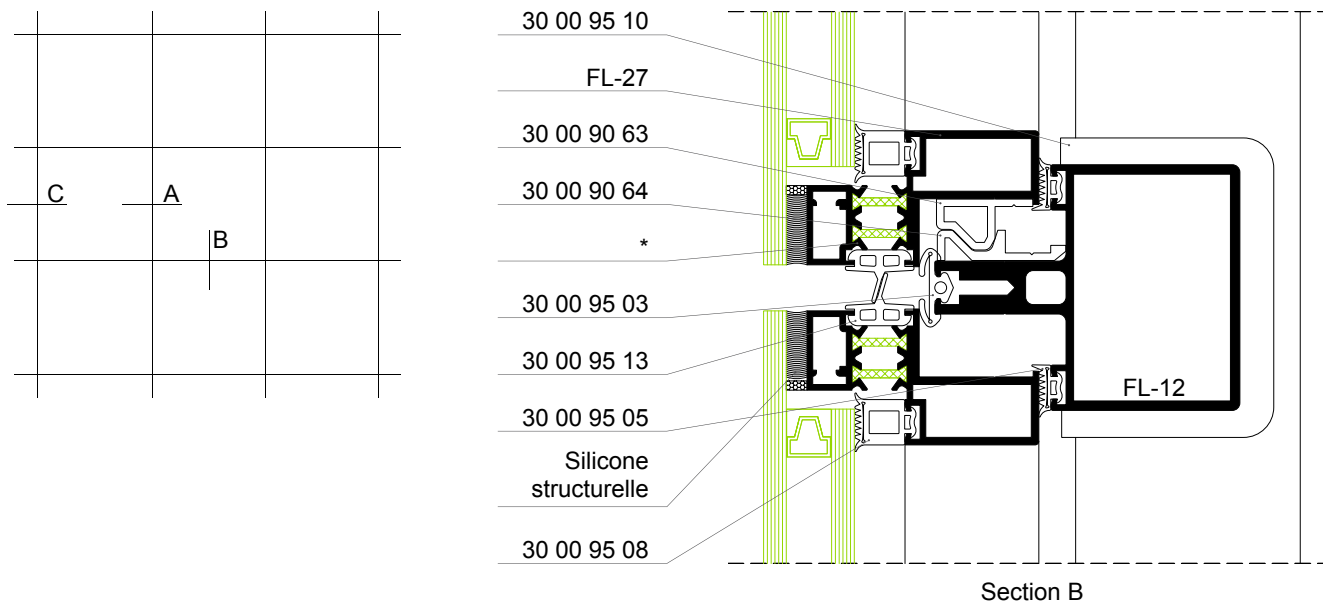

* Profil anodisé avec classe 20, colle spéciale avec silicone structurelle

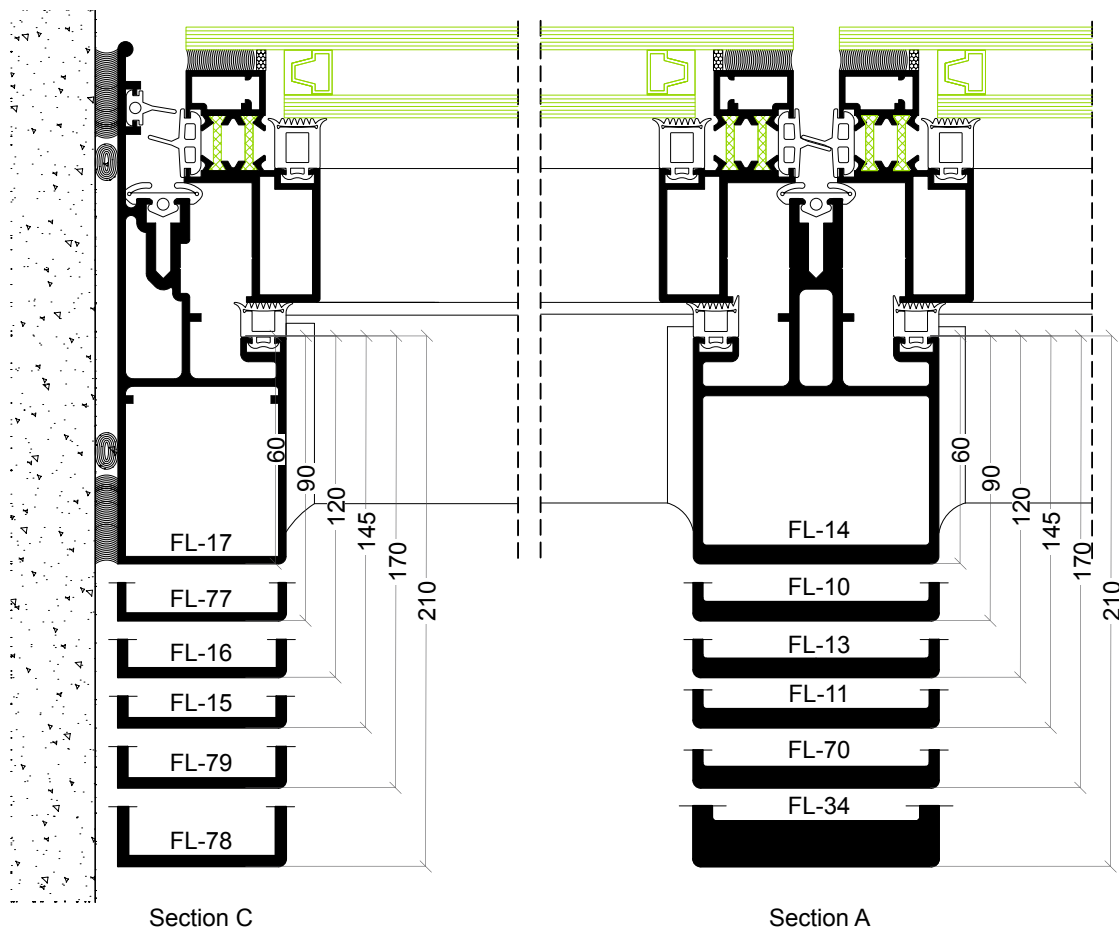

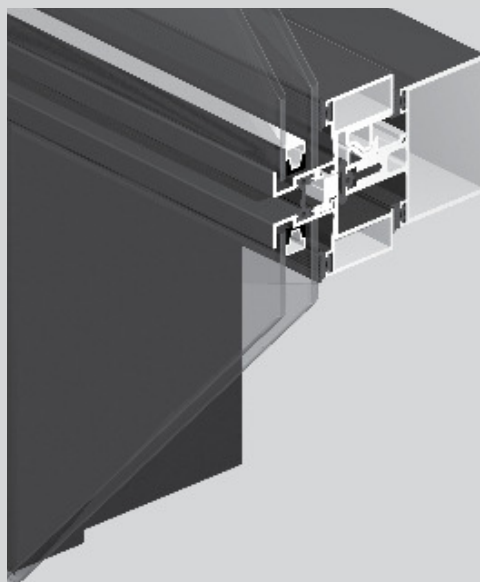
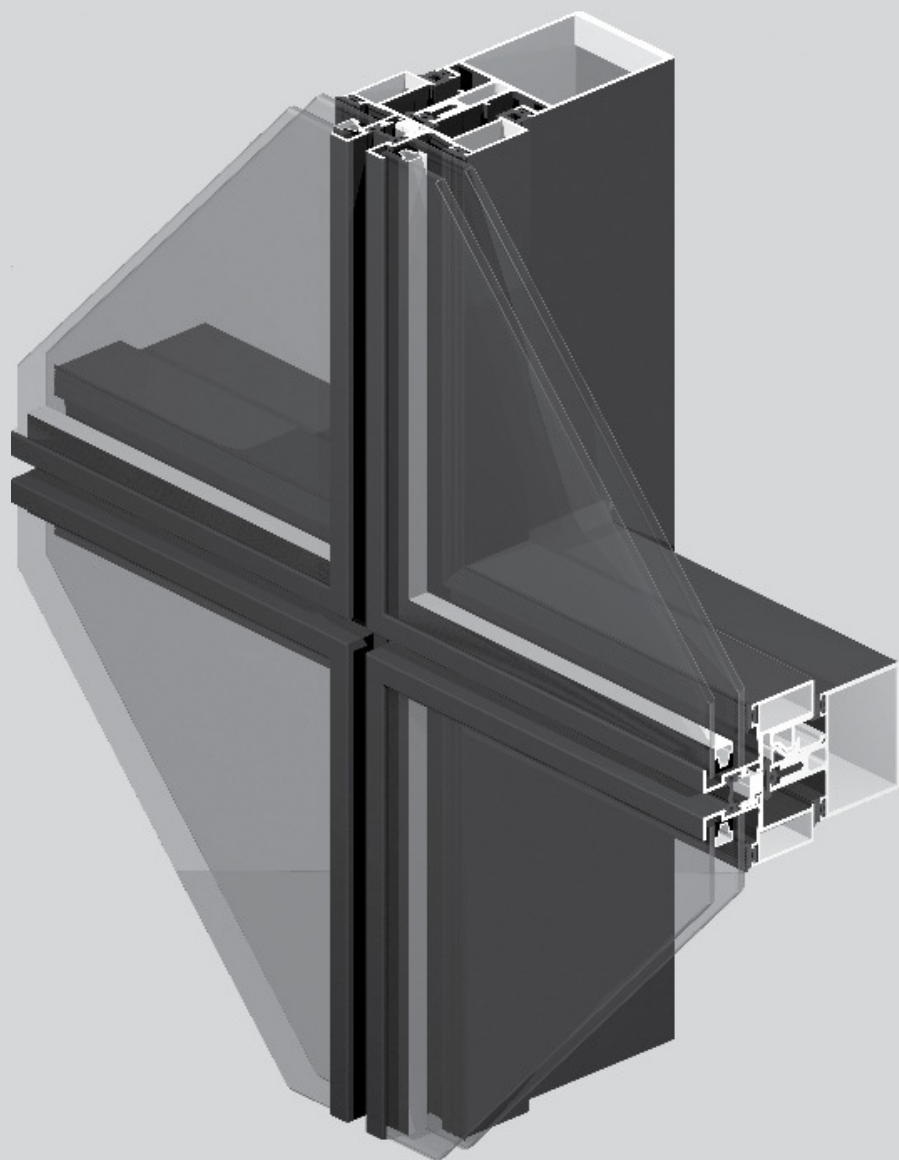

**Façade
Demi
Structurelle**

Façade Demi-Structurelle

Caractéristiques

Système de façade dans lequel les profilés sont utilisés pour la fabrication des ouvrants, avec un rebord qui fixe le verre, évitant l'utilisation de silicone structurelle.

Le section de vue extérieur de système c'est 12 mm ou 21 mm.

Le section des montants et traverses c'est 65 mm, visible seulement de intérieur. Les deux profils présents canaux de drainage et de ventilation qui assurent, jointment avec le système de joints EPDM, une étanchéité et perméabilité maximales. Possibilité de profils avec rupture thermique.

Possibilités d'ouverture

Ouverture italienne réalisé à travers de compass en axe inox avec une résistance à 180 kg, tellement ouvrants fixes comme l'italiennes sont fabriqués avec le même profil périmétrale, rendant ainsi imperceptible sa distinction par l'extérieur.

Détail horizontale et verticale

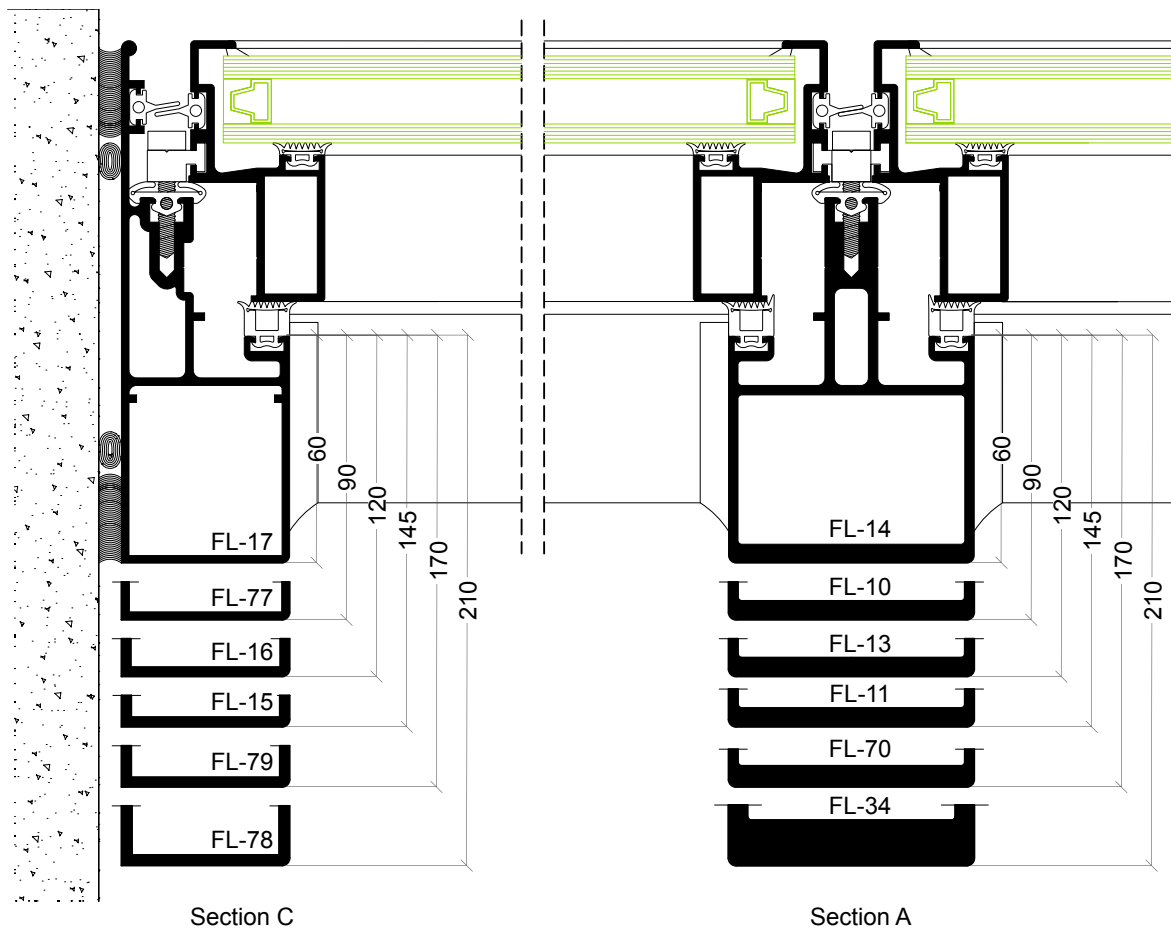
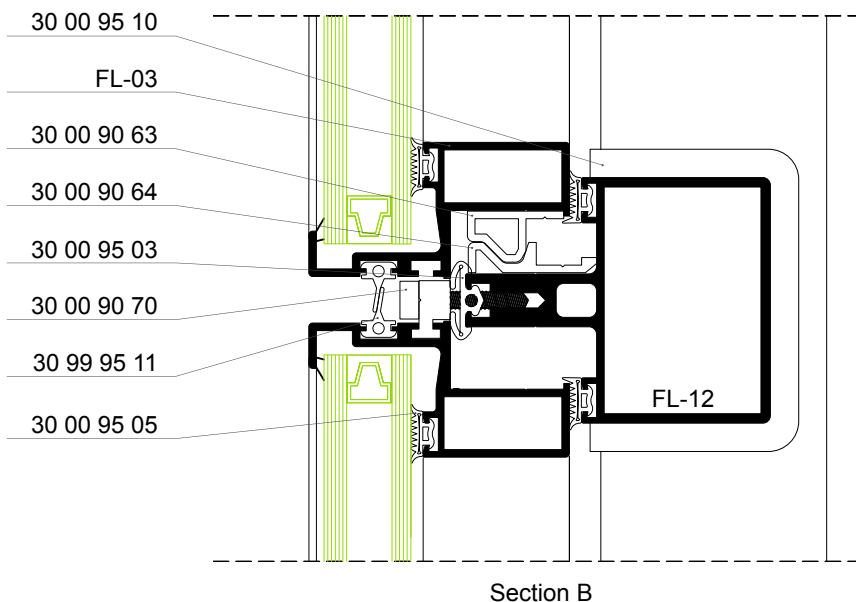
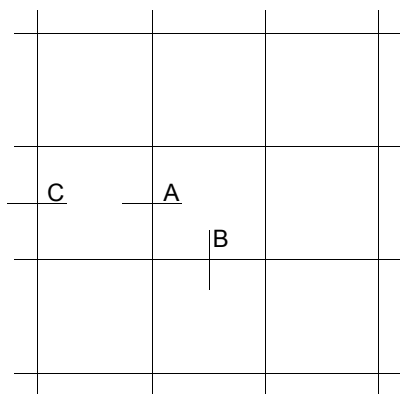

Détail coin 90°

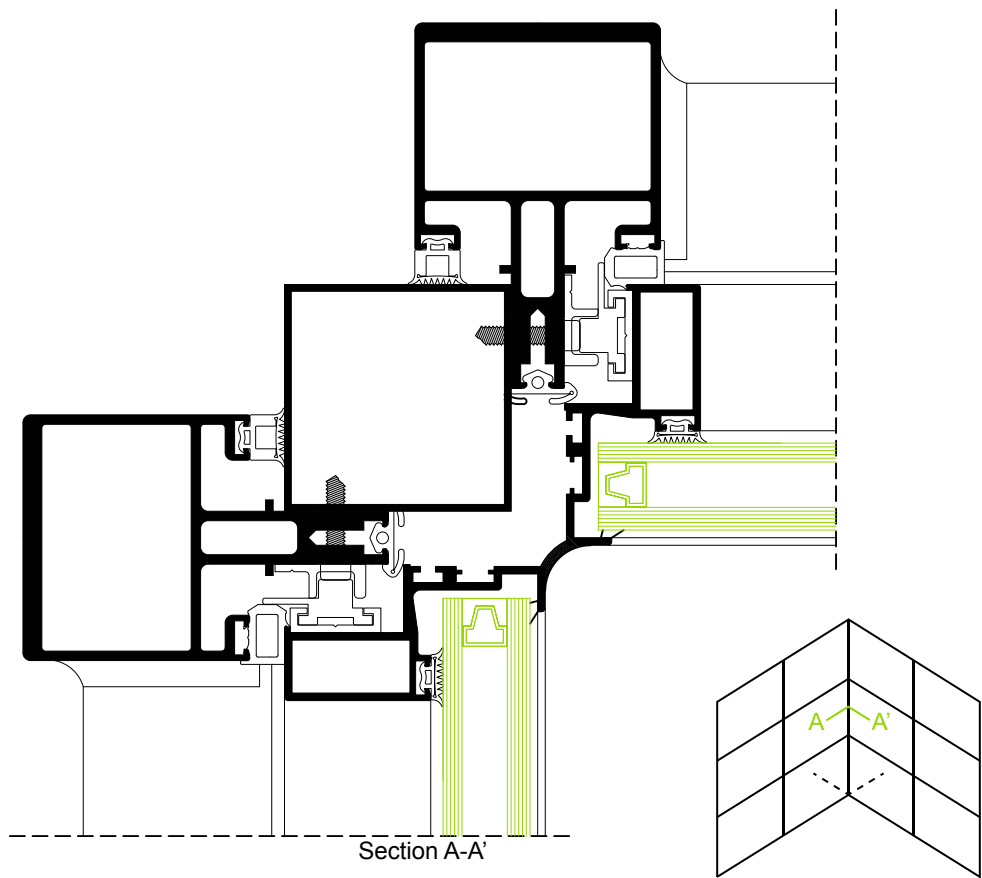

408

Détail coin 90°

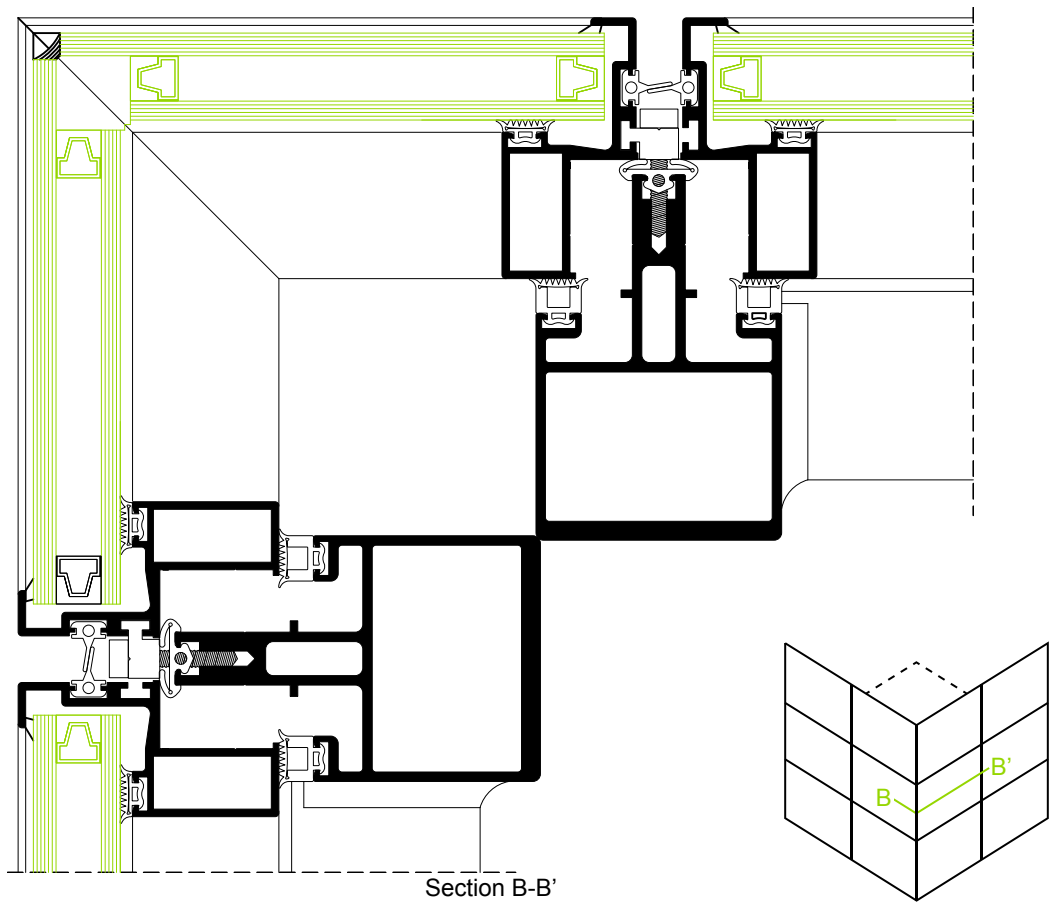

Détail coin 90°

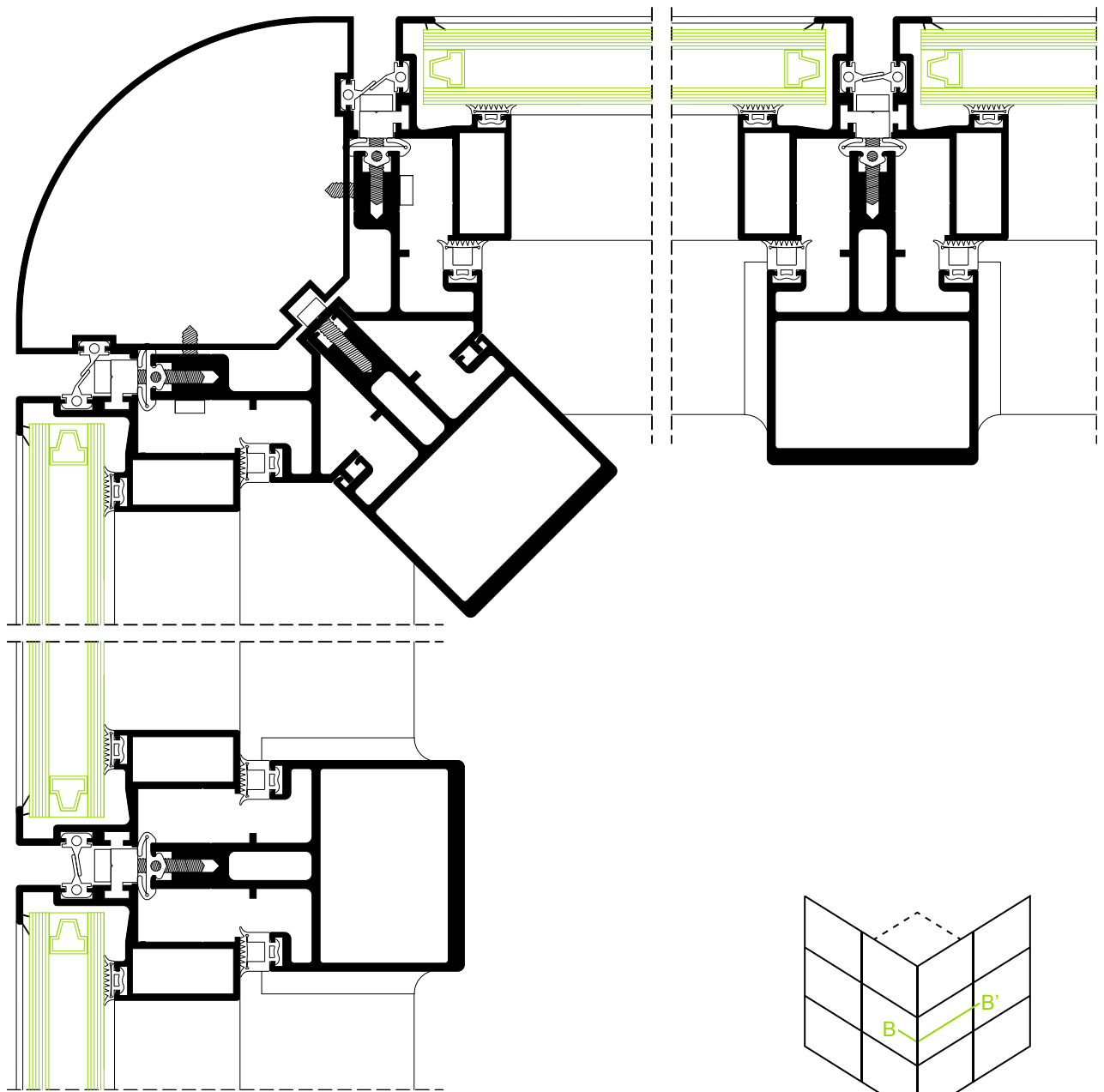

Section A-A'

Détail horizontale et verticale

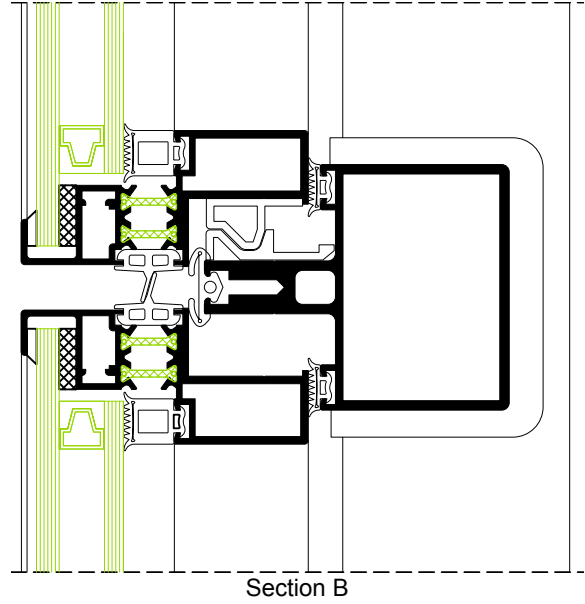
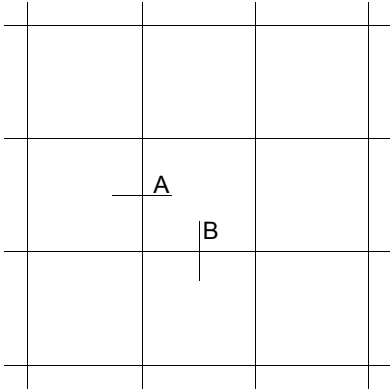

410

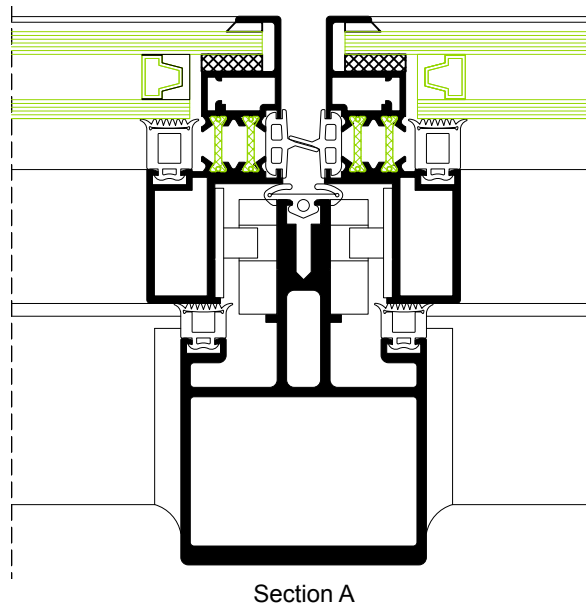

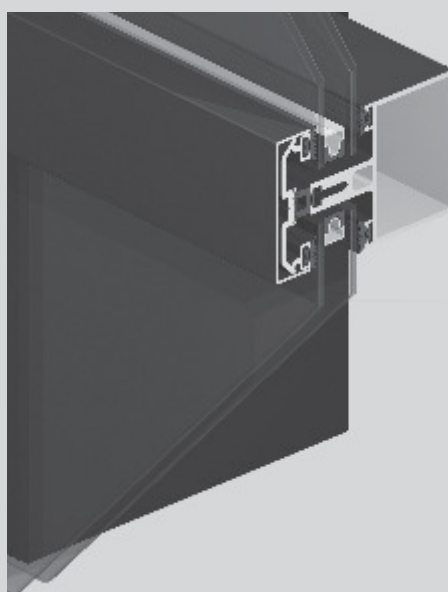
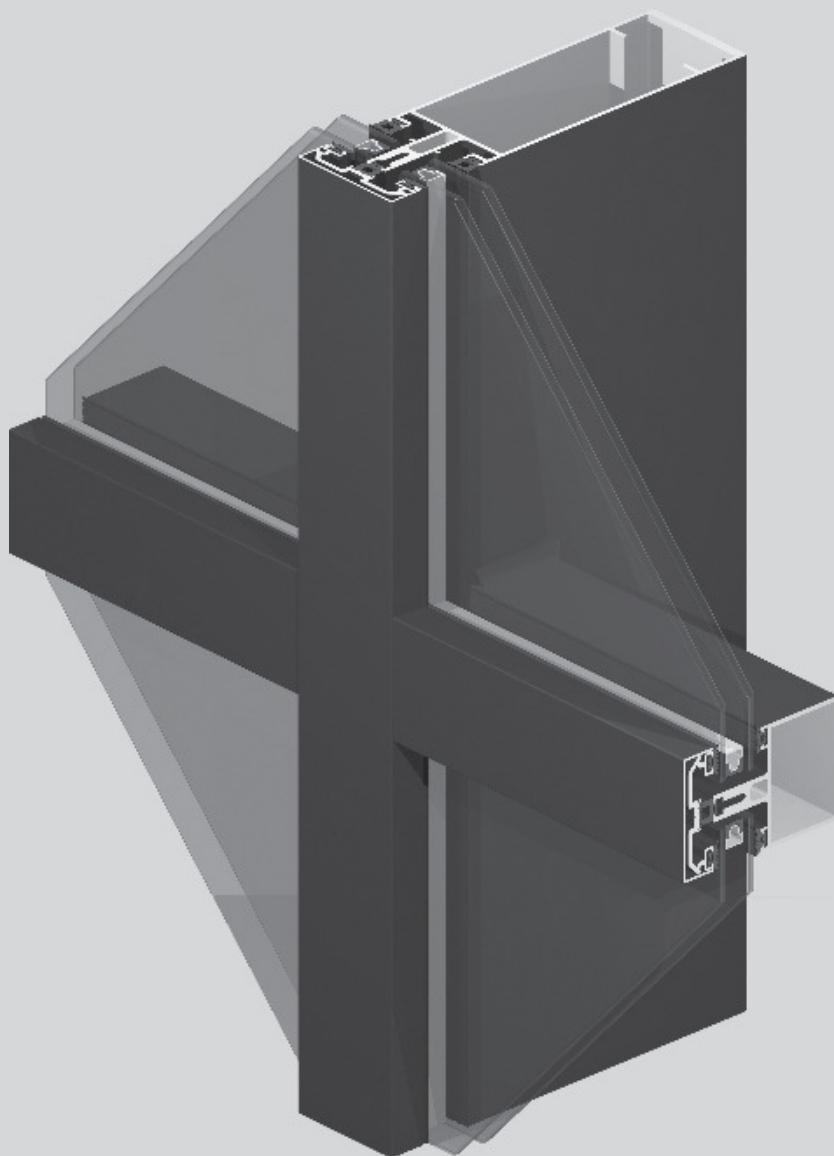

**Façade
Mur
Rideau**

Façade Mur Rideau

Caractéristiques

Dans ce système le placement de verres est effectuée à travers une profil avant bouchon qui fixe le verre à la structure portante. Sur ce profil est placée une couverture extérieur, horizontale et verticalement, formant une vue extérieur sur les deux dimensions. Le section visible de intérieur et extérieur des montants et traverses c'est 65 mm. Les deux profils présentent canaux de drainage et de ventilation qui assurent, jointment avec le système de joints en EPDM, une étanchéité et perméabilité maximales.

Possibilités d'ouverture

Ce type de façade, au contraire de tous les autres, permet tout type d'ouverture fournies par les systèmes Anicolor. La fenêtre c'est fixe à la structure avec l'aide de profil pressage qui fixe le verre à façade. Il y a aussi la possibilité de réaliser des ouvertures italiennes "cachés", c'est-à-dire, non visibles par extérieur.

Catégories obtenus en banc d'essai:

1. Perméabilité a l'air: Classe C
2. Étanchéité a l'eau: 600 Pa
3. Résistance au vent: 2400 Pa
4. Essai de sécurité: 3600 Pa

Façade Mur Rideau – Bouchon Elliptique

Caractéristiques

Système dérivé de Façade Mur Rideau mais qui offre une esthétique extérieur distincte. Dans le sens verticale, les verres caché la structure portante, produire une union verre-verre, tandis que horizontale, à propos le profil pressage qui fixe le verre, est placé une couverture avec forme elliptique ou ronde, mettant en évidence la vue horizontale cette type de façades. La section visible, par l'intérieur, par l'extérieur des montants et traverses c'est 65 mm. Les deux profils présents canaux de drainage et de ventilation qui assurent, jointment avec le système de joints EPDM, une étanchéité et perméabilité maximales.

Possibilités d'ouverture

Ce type de façade, au contraire de tous les autres, permet tout type d'ouverture fournies par les systèmes Anicolor. La fenêtre c'est fixe à la structure avec l'aide de profil pressage qui fixe le verre à façade. Il y a aussi la possibilité de réaliser des ouvertures italiennes "cachés", c'est-à-dire, non visibles par extérieur.

Détail horizontale et verticale

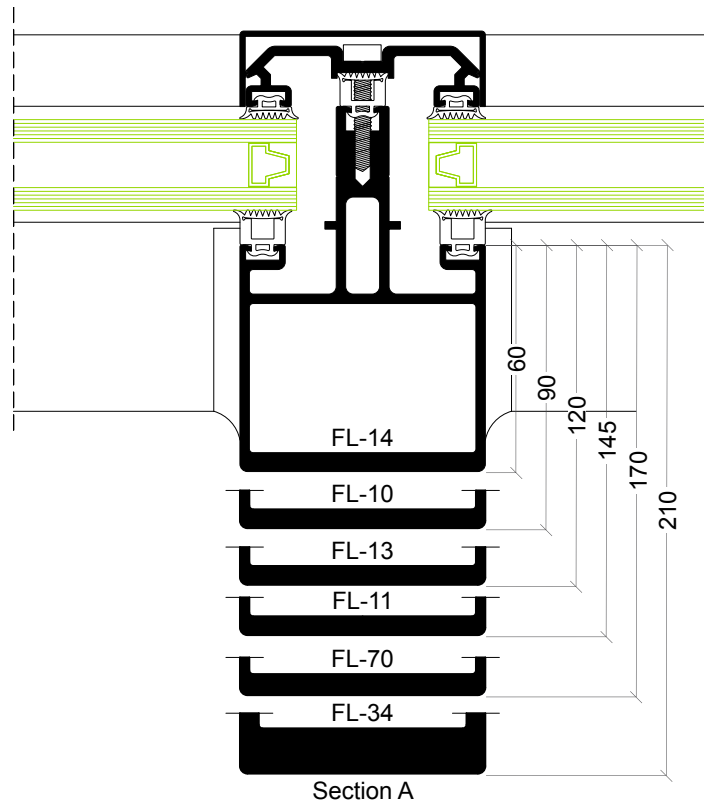
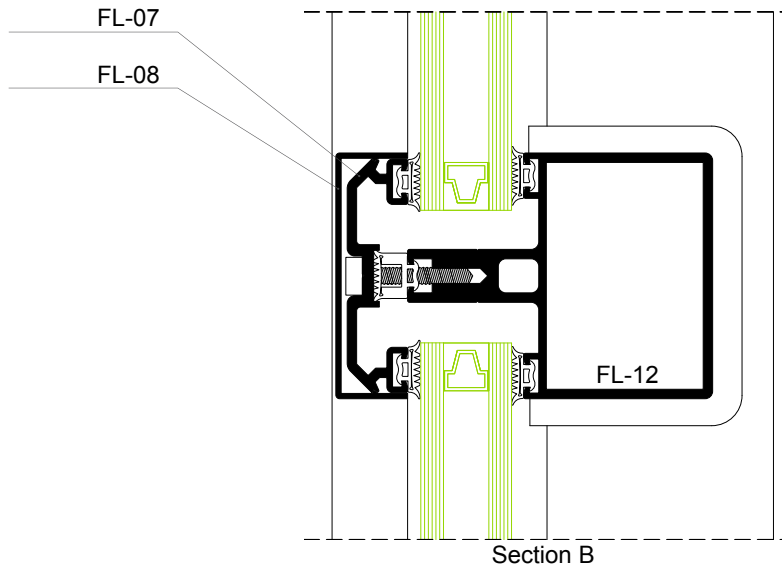
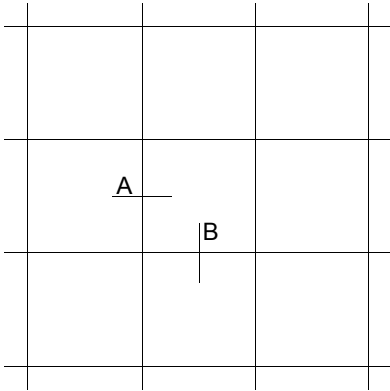

**Détail horizontale et verticale
Fenêtre italienne-deslizant (AXi)**

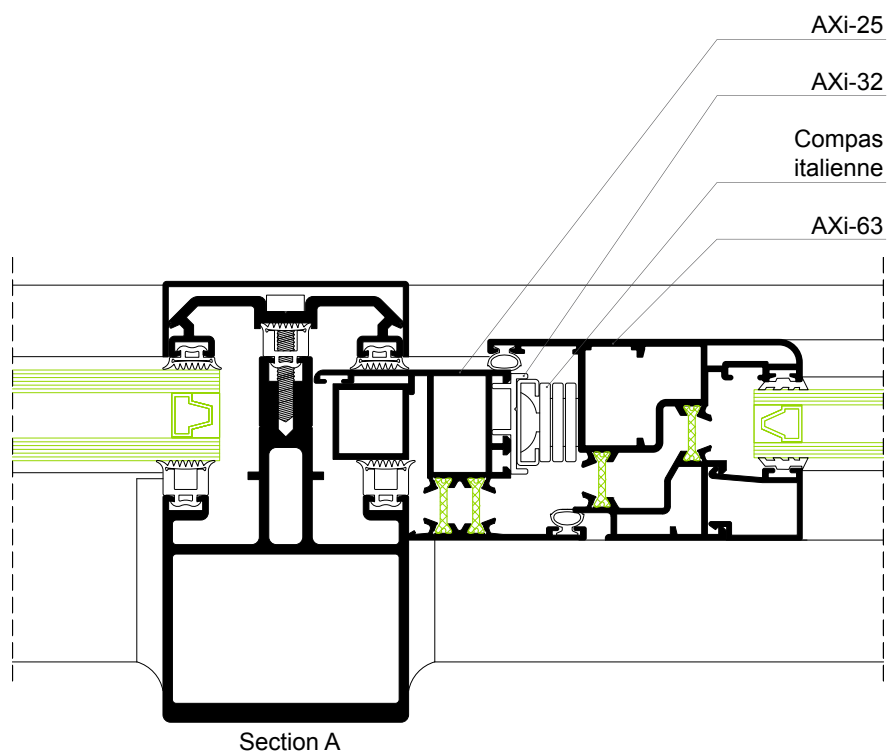
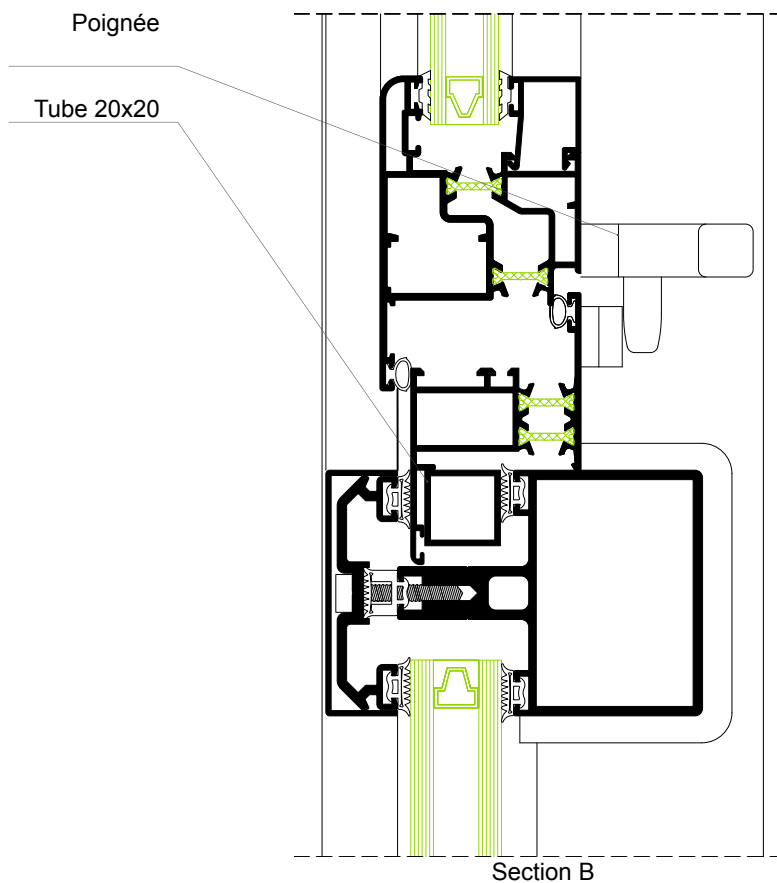
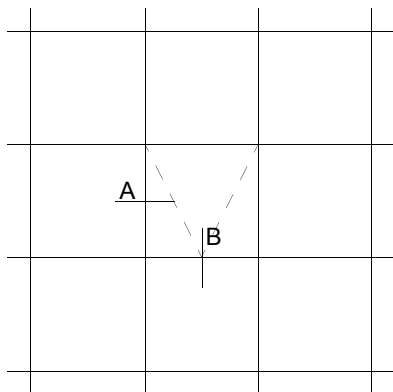

**Détail horizontale et verticale
Fenêtre italienne-deslizant (ouvrant caché)**

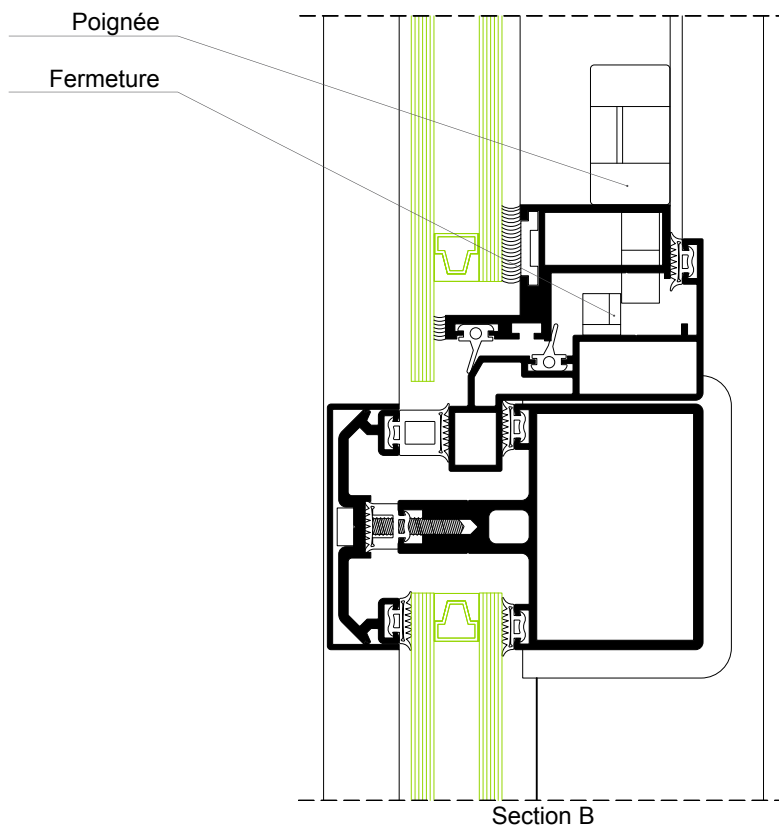
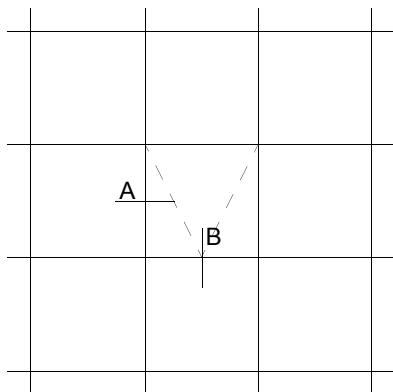

415

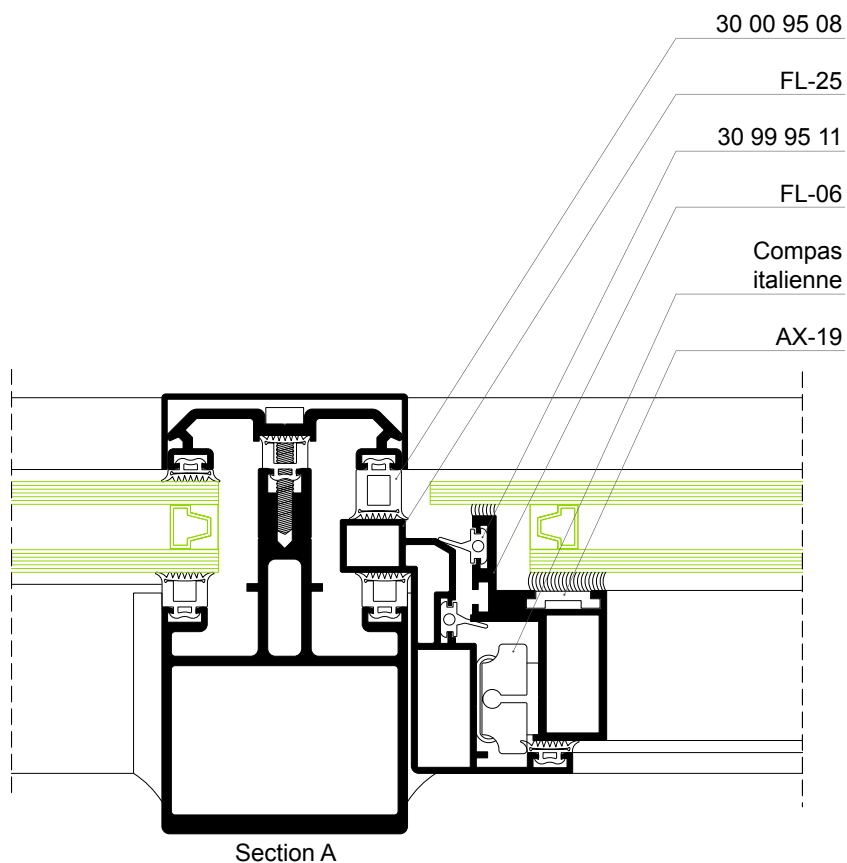

Détail coin 90°

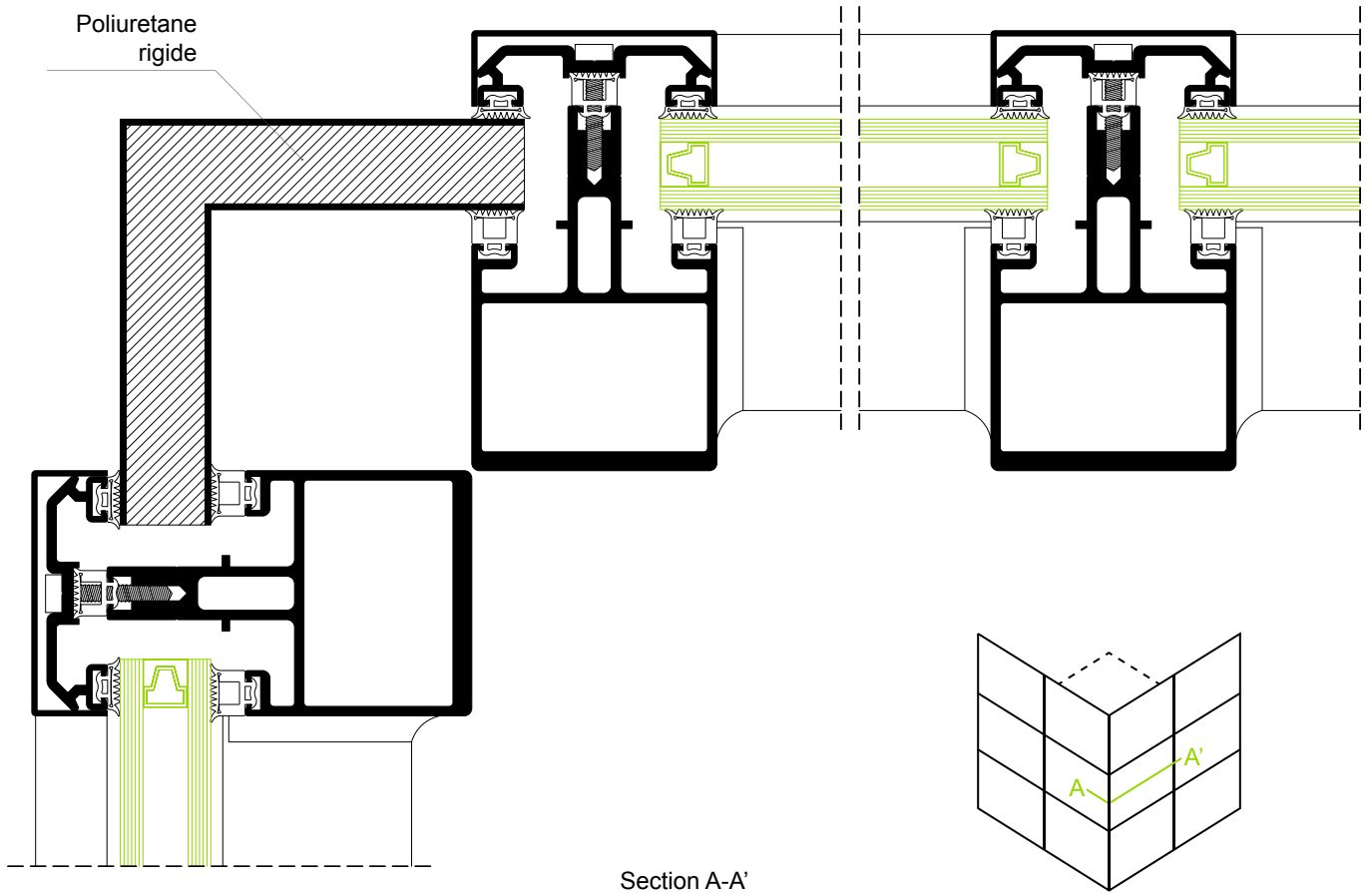

416

Détail coin 90°

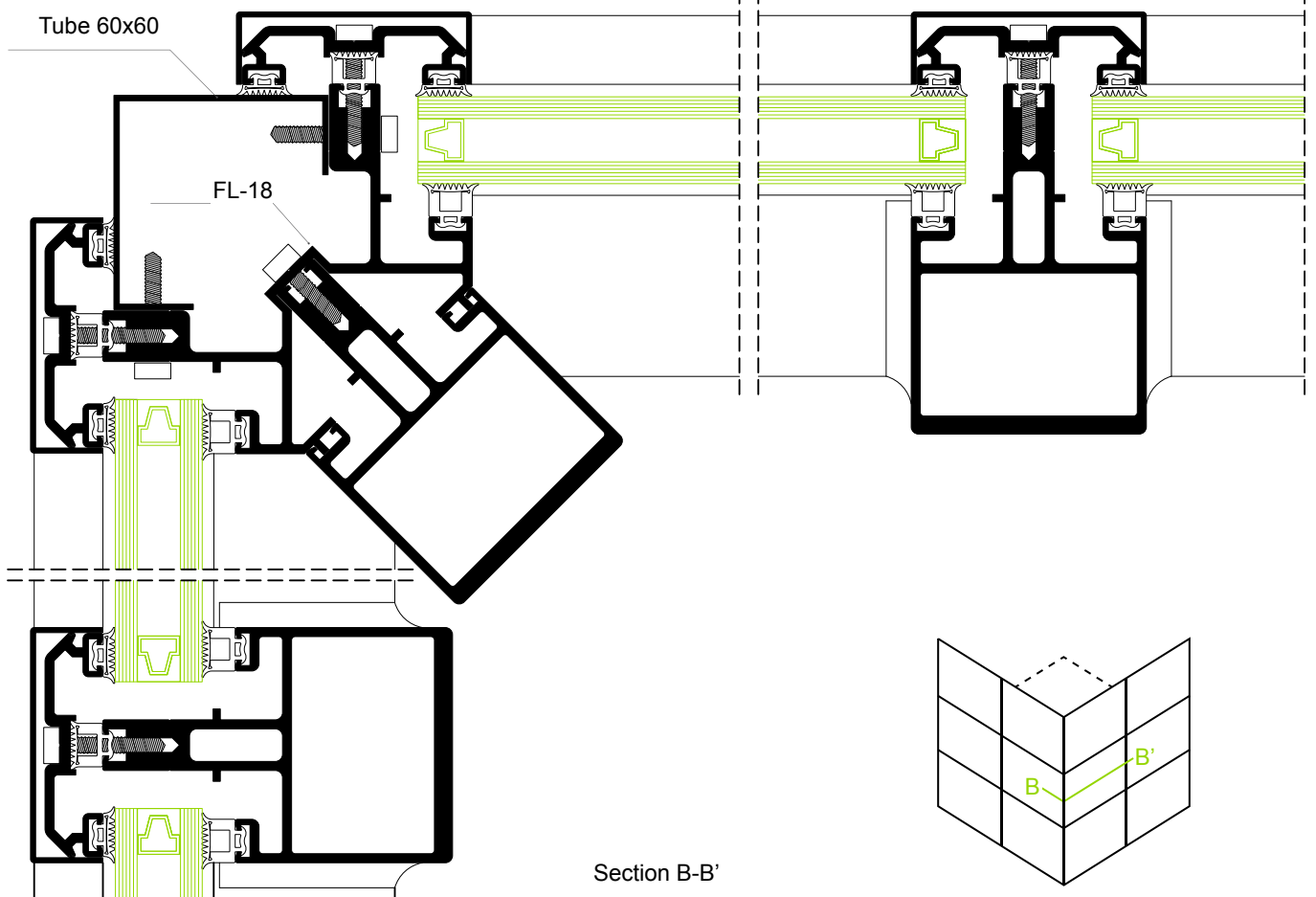

Détail coin 90°

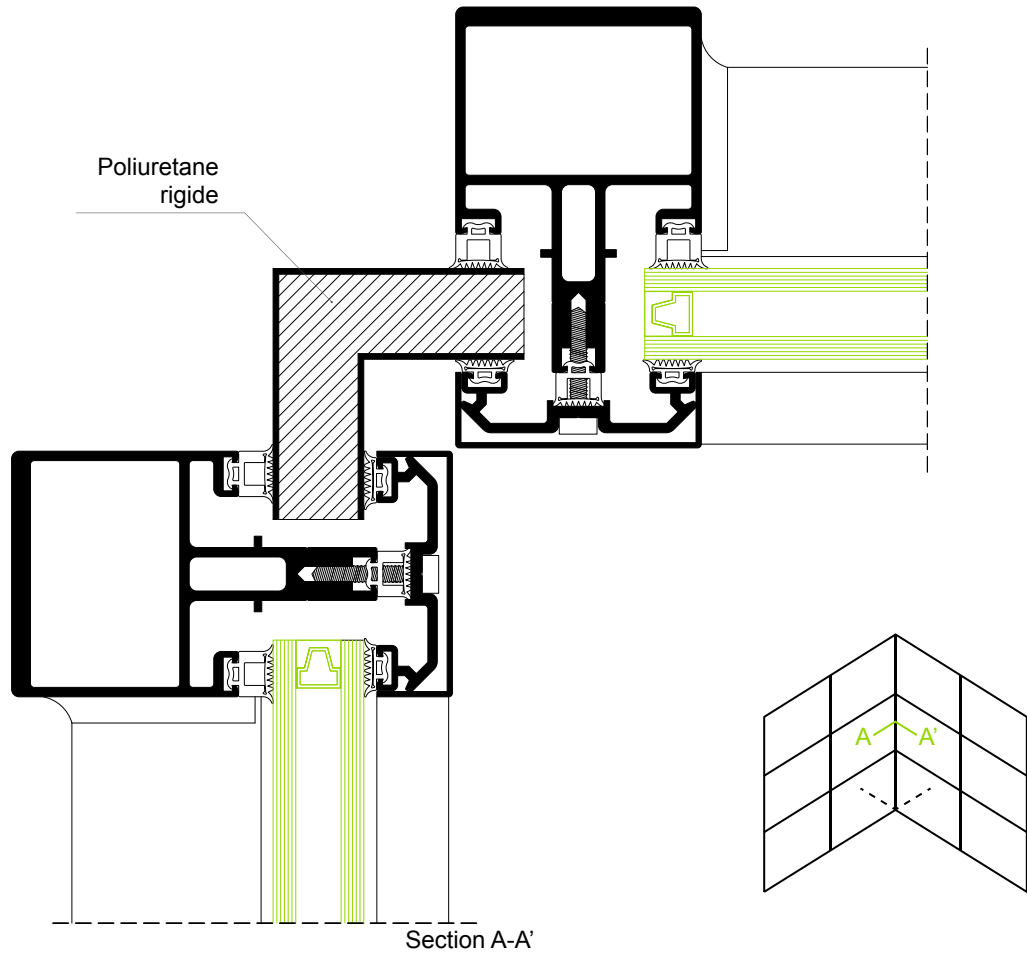

Verre

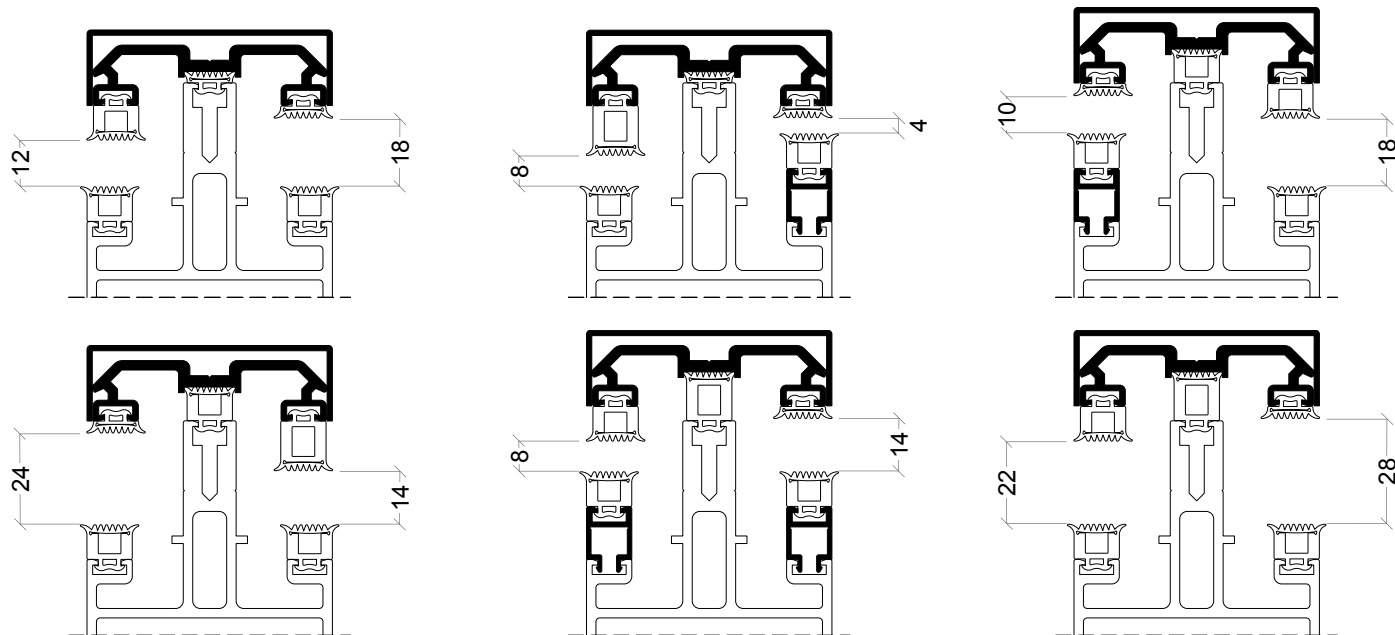

Verre

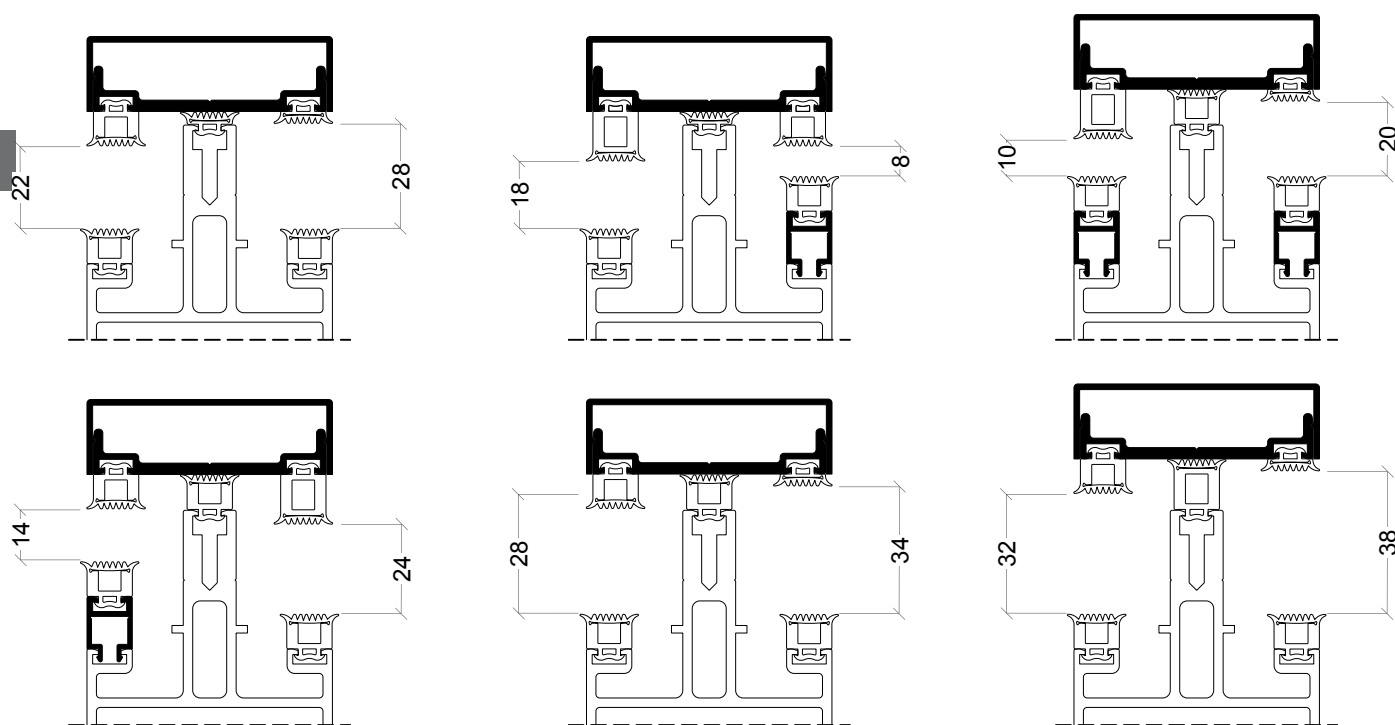

4 1 8

Référence	Dessin	Description
FL-32		Supplément de mur rideau
30 00 95 01		Joint intérieur montant Joint central montant et traverse (mur rideau)
30 00 95 05		Joint intérieur de traverse
30 00 95 08		Joint central montant et traverse

Détail horizontale et verticale

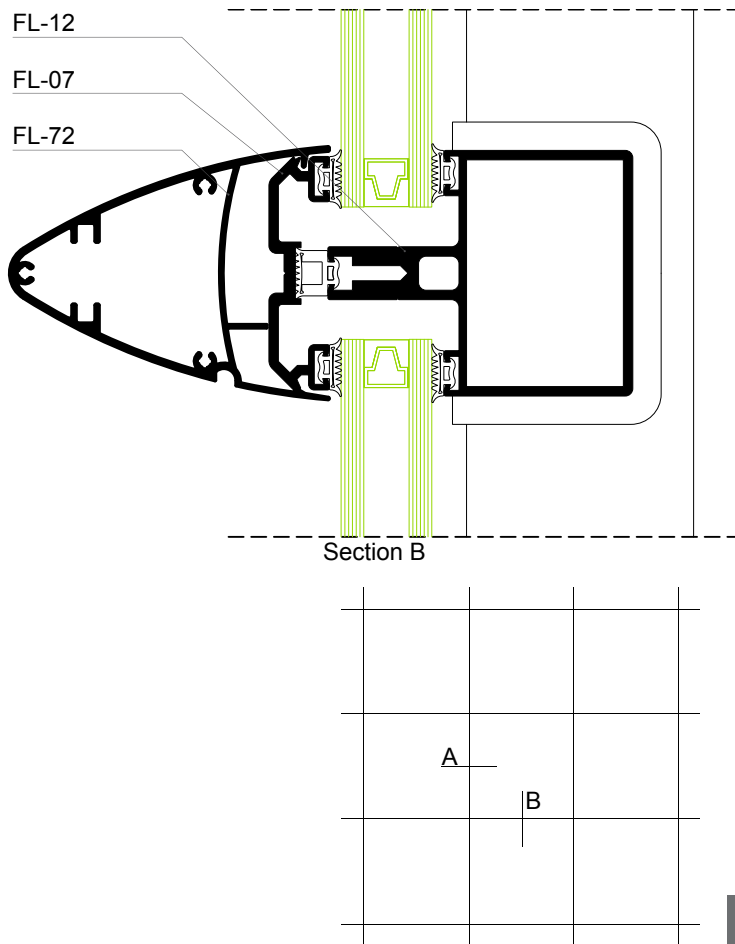
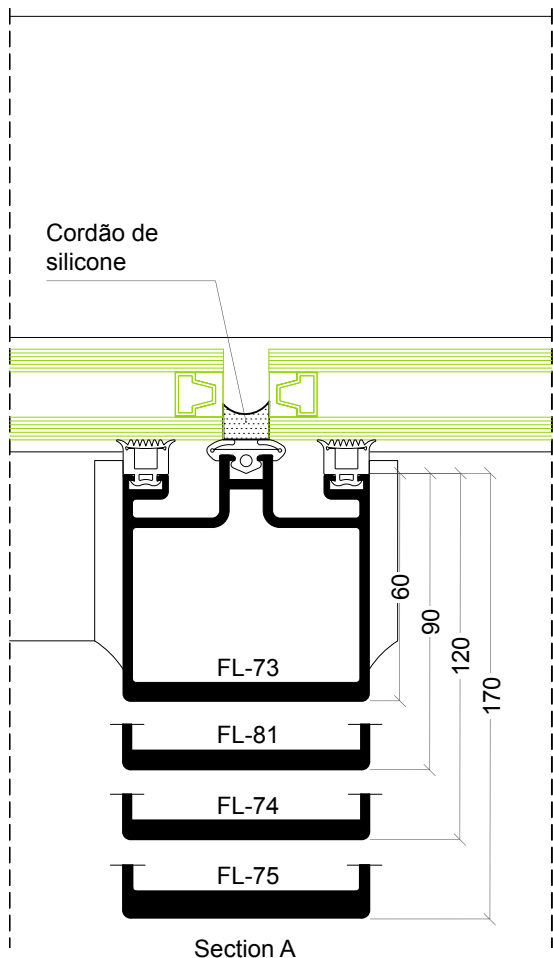

Détail horizontale et verticale
Fenêtre italienne

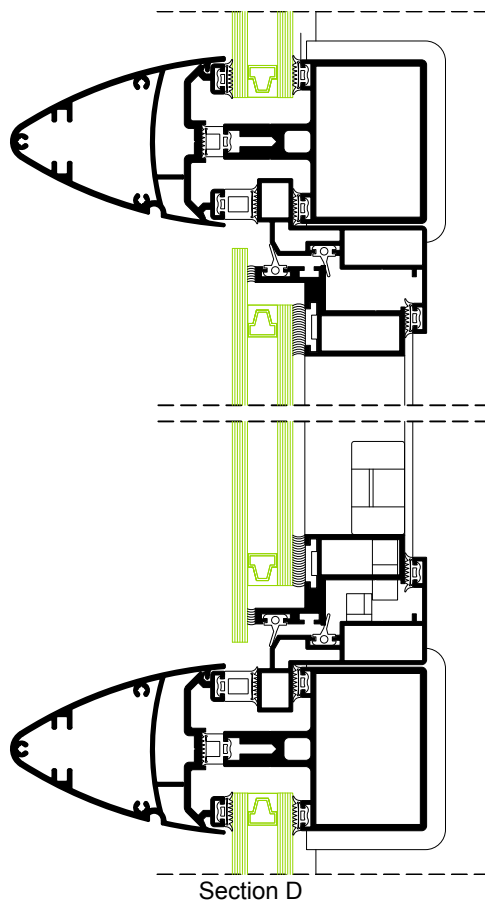
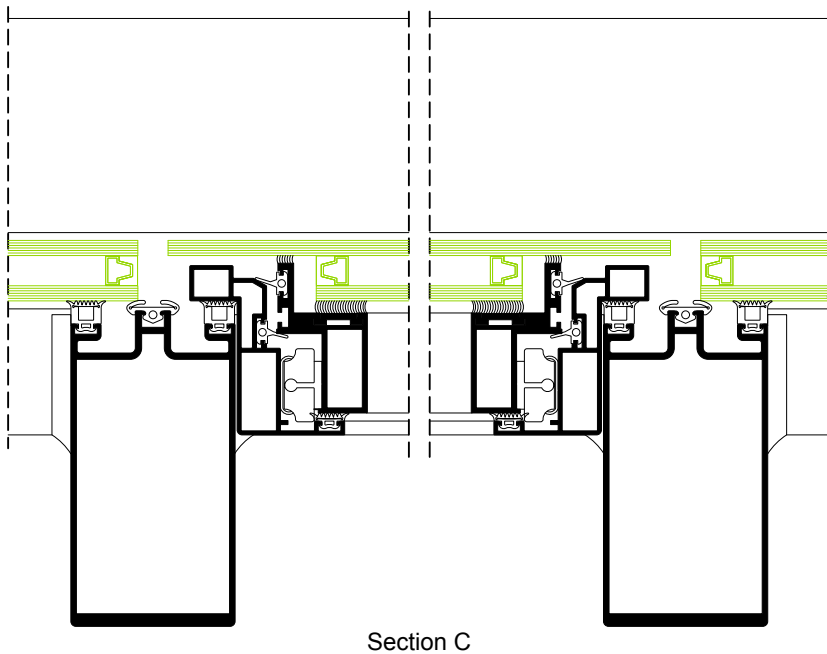
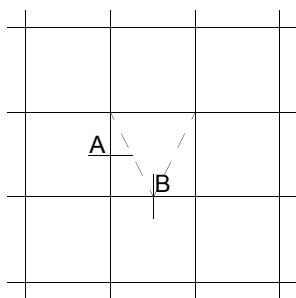

Détail coin 90°

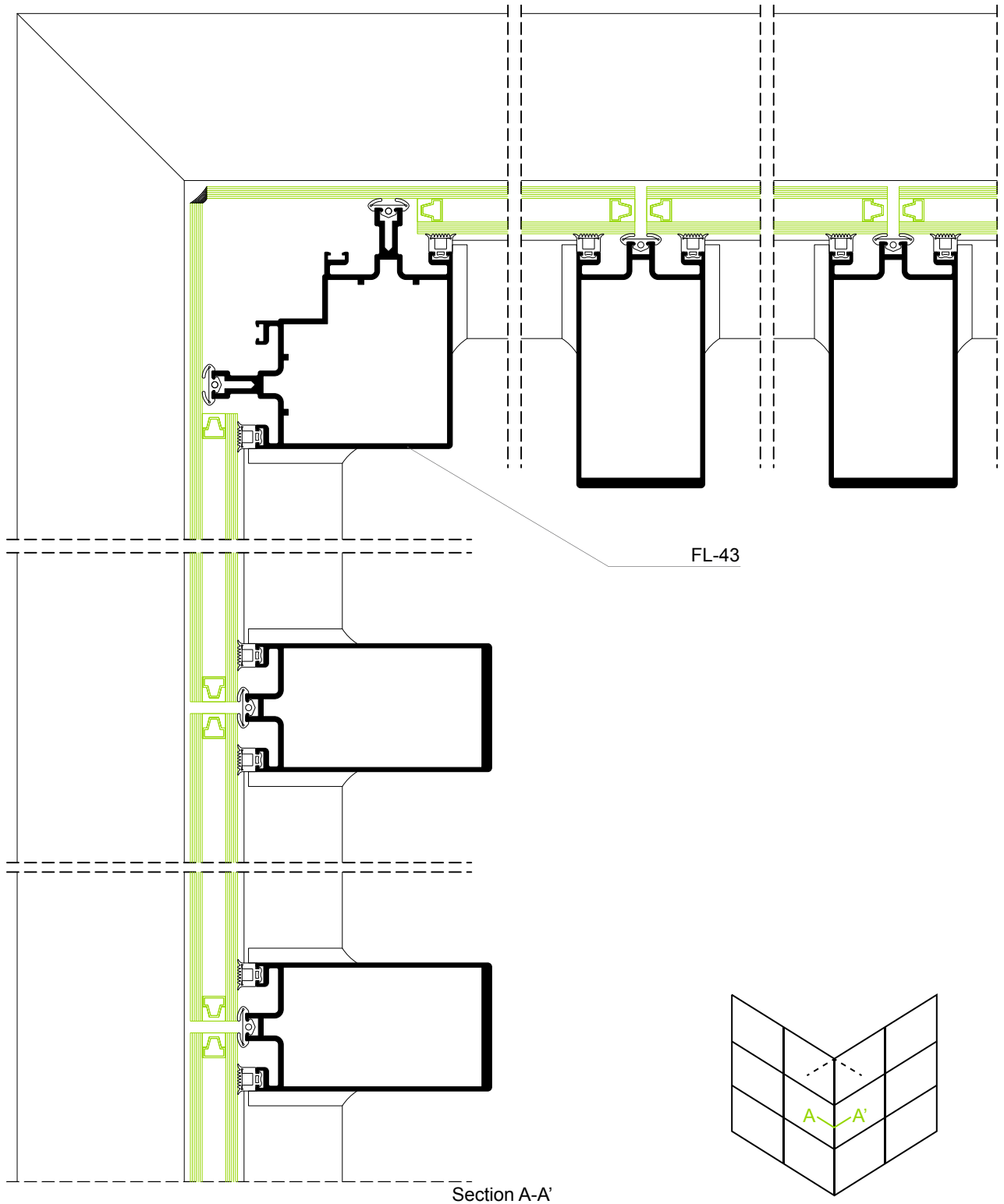



**Système
Ergolux**

Système Ergolux

Caractéristiques

Ce système utilise le principe fondamental des canaux de drainage et de ventilation des systèmes de façade. Il se complémente avec des profils qui permettent d'adopter différentes solutions, à la fois dans les puits de lumière et les vérandas. Il peut ainsi se créer de nouveaux espaces avec beaucoup de luminosité.

Les profils de ce système ont une section visible intérieure de 65 mm, pendant que sa profondeur varie en fonction des besoins du calcul statique (structure portante, charge de neige, zone vent, etc.). De même mode, il y a une large gamme de couvertures appuyant de verre avec diverses possibilités de réglage, qui permettent ainsi d'obtenir les angles nécessaires pour chaque cas. Ce système, appliqué sur couvertures ou solariums, contient des profils de connexion avec et sans rupture thermique, qui permettent l'utilisation de tout type d'ouverture. La totale étanchéité du système est assurée par l'ensemble de joints en EPDM, résistant aux agents atmosphériques.

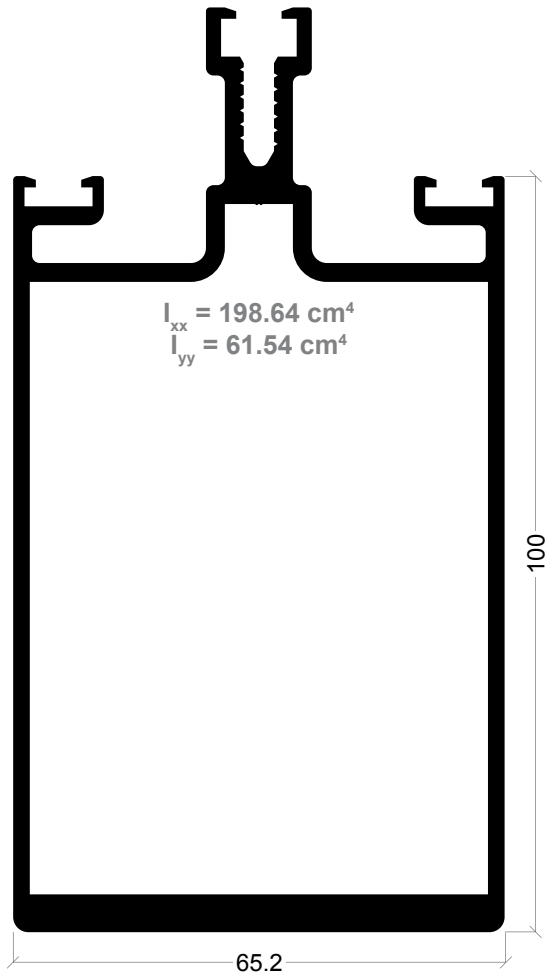

FL-41
Montant 100 mm

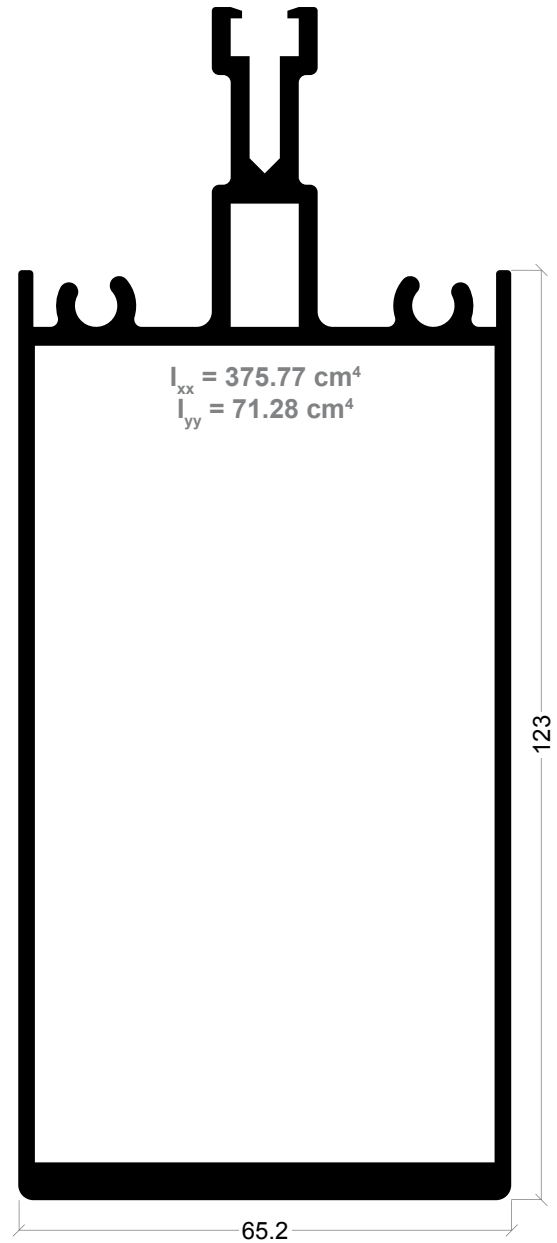

FL-56
Montant réglable

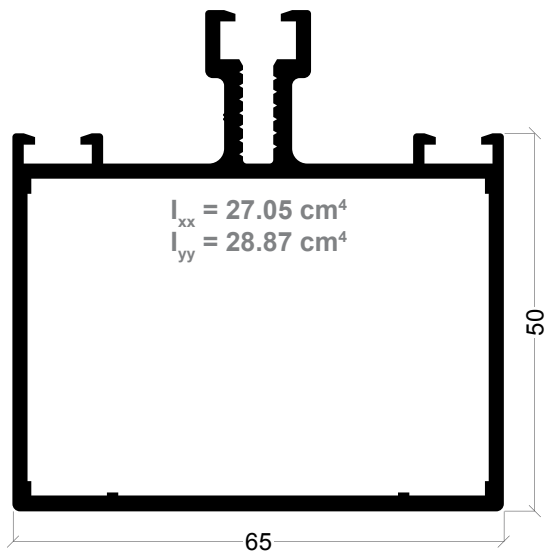

FL-42
Traverse

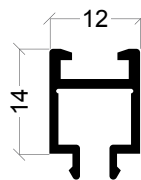

FL-32
Supplément

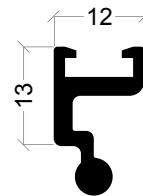

FL-23
Porte joint réglable

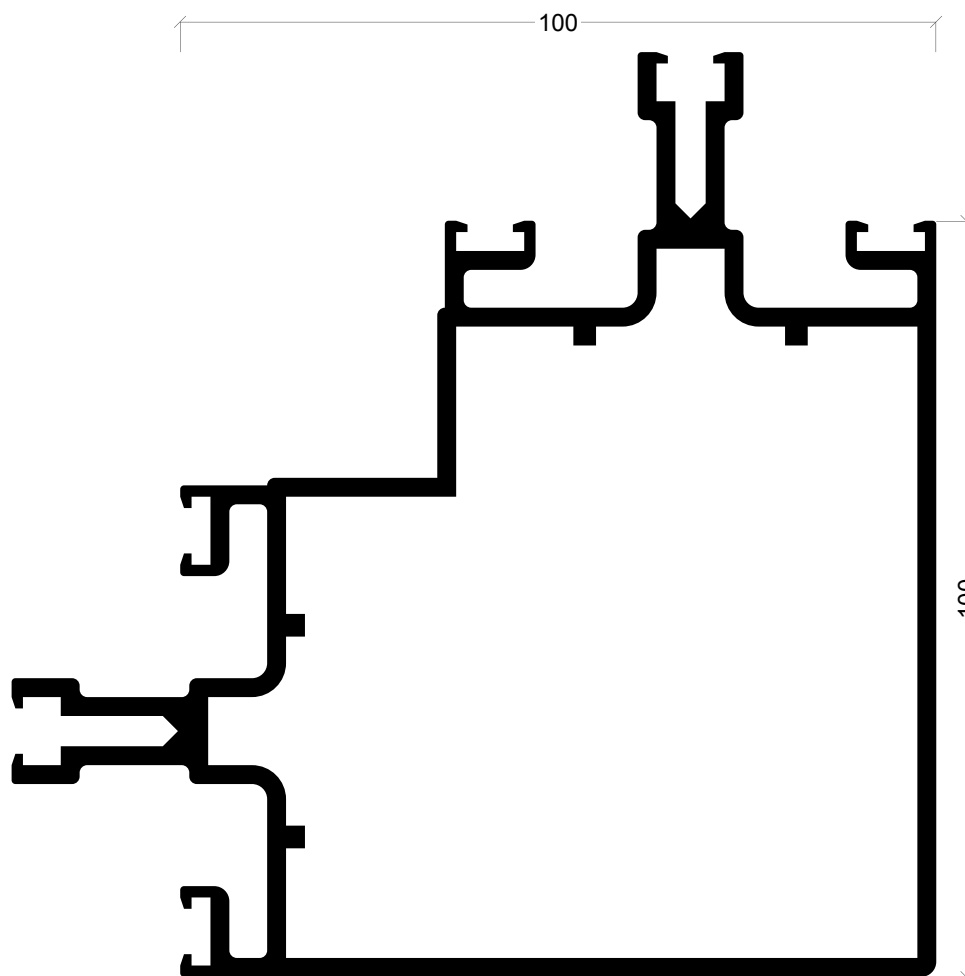

FL-43
Coin 90°

424

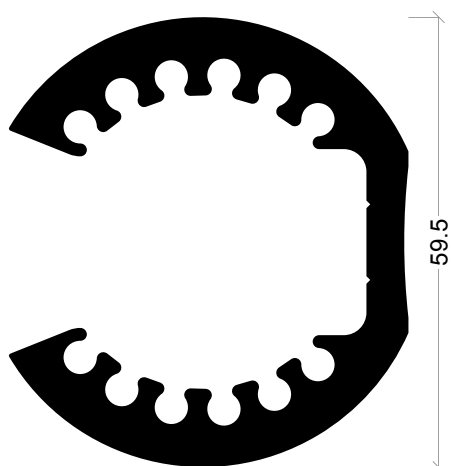

FL-69
Haut de fixation

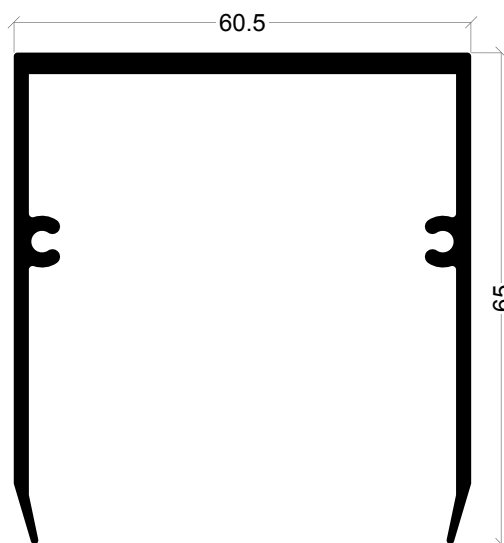

FL-68
Haut de traverse

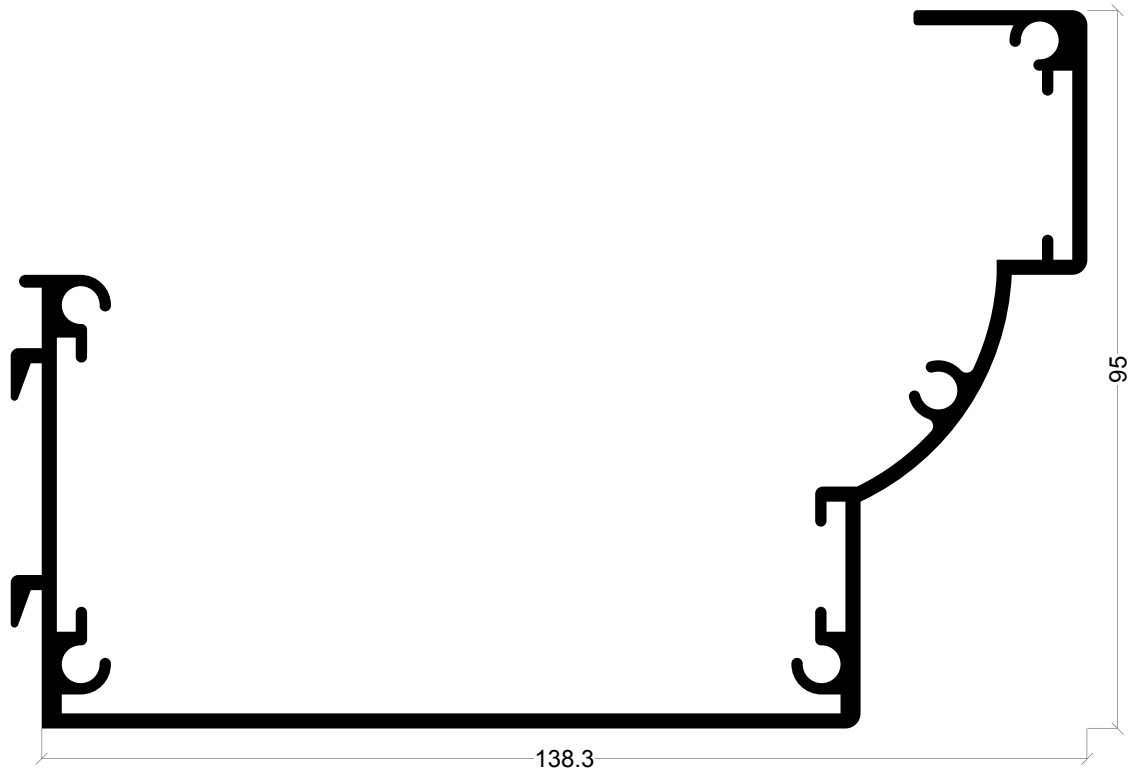

FL-57
Pignon

425

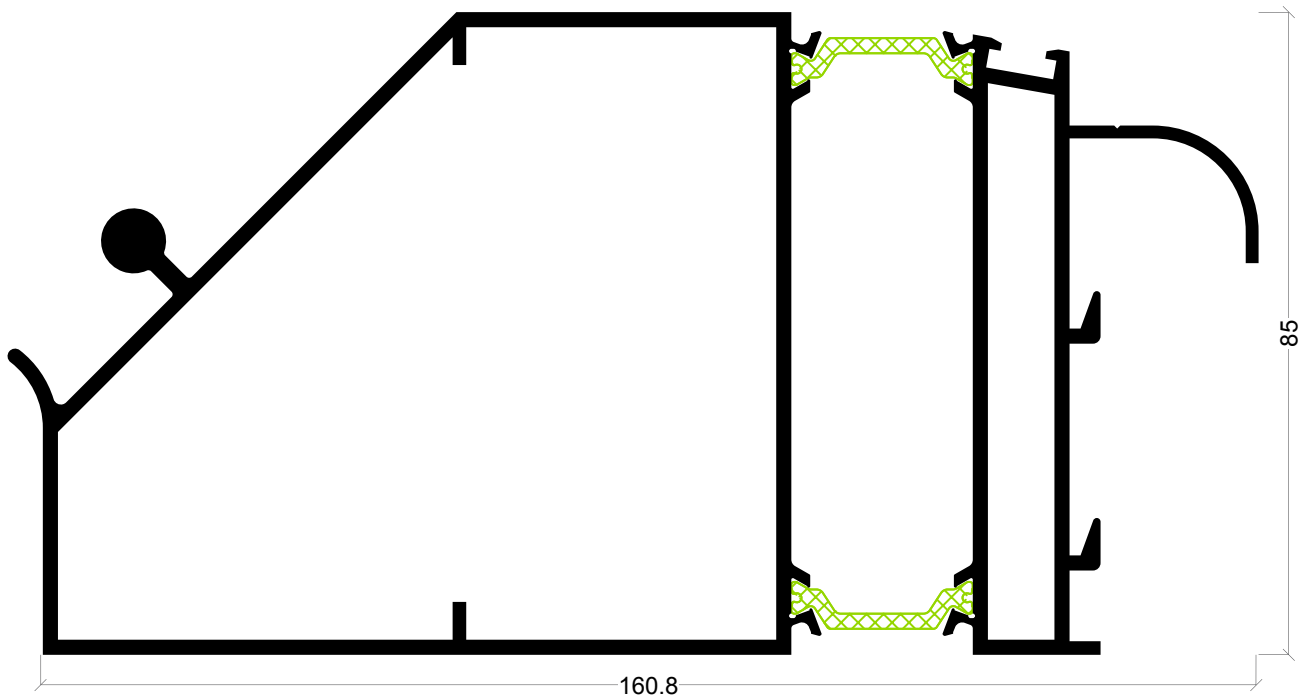

FL-60
Porte soufflet inférieur

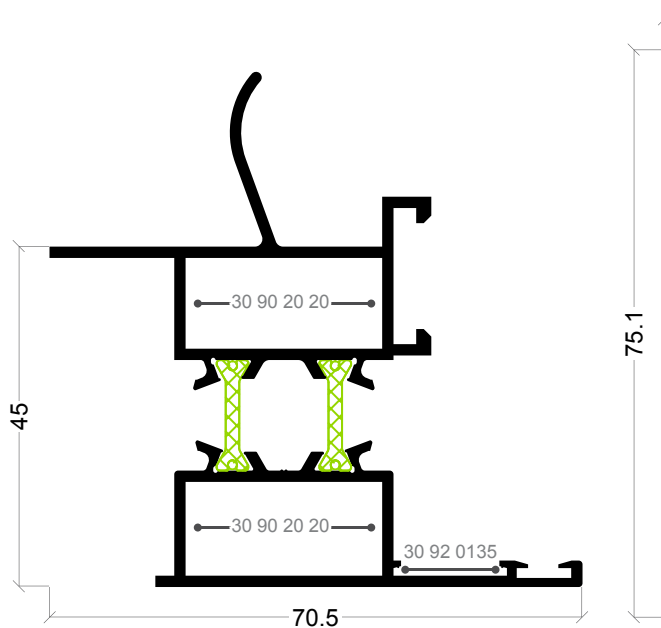

FL-65
Dormant lumière

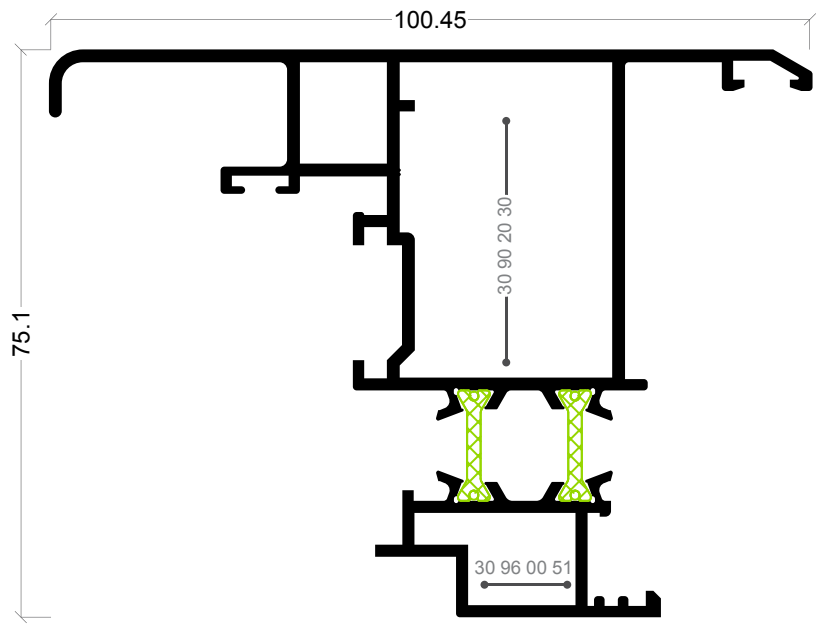

FL-64
Profil ouvrant lumière

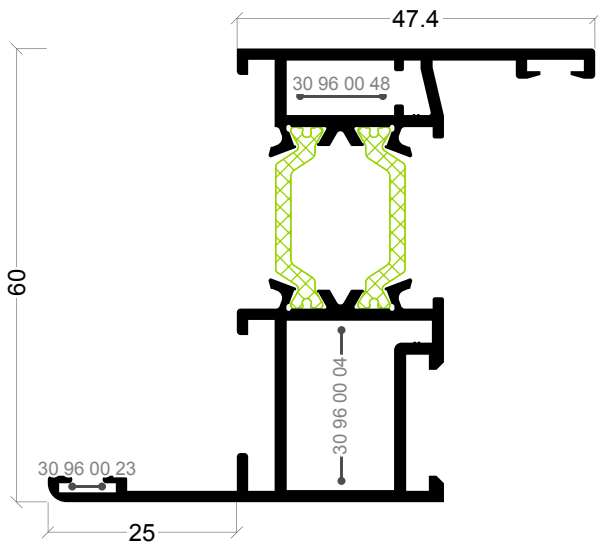

ARi-35
Dormant avec finition 25 mm

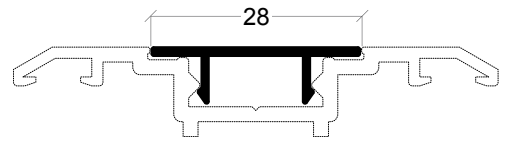

FL-66
Bouchon

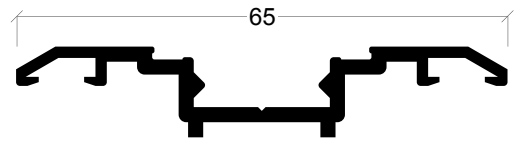

FL-44
Profil avant bouchon

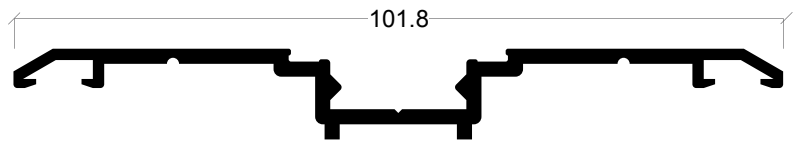

FL-59
Profil avant bouchon (plier en brut)

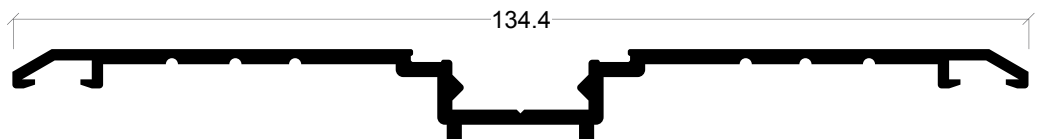

FL-67
Profil avant bouchon (plier en brut)

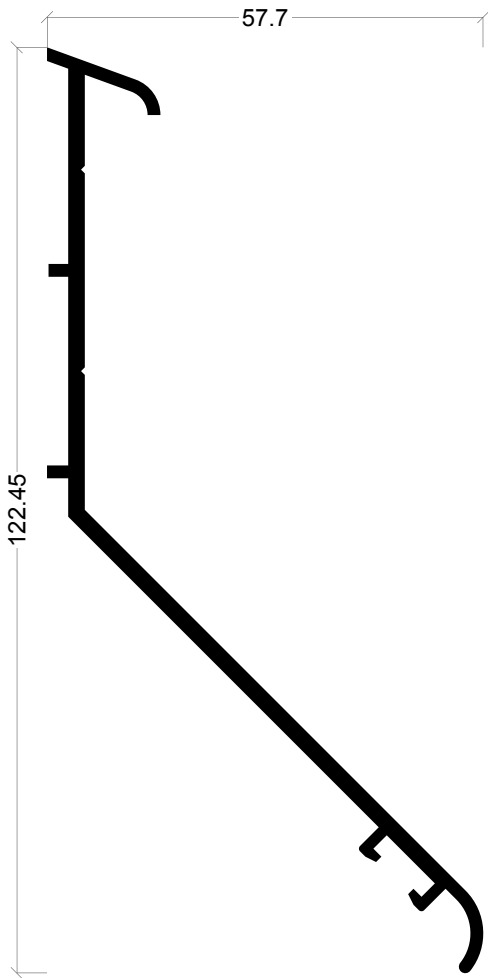

FL-63
Rejet d'eau supérieur

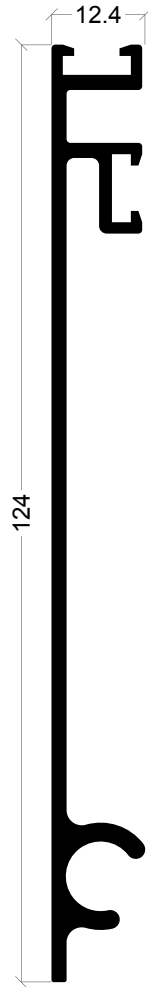

FL-62
Soutien montant soufflet

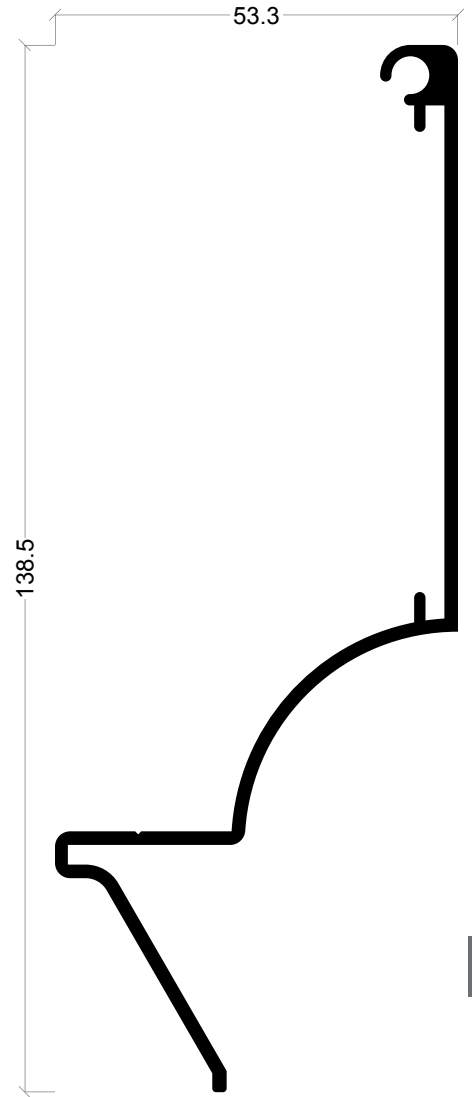

FL-58
Supplément pignon

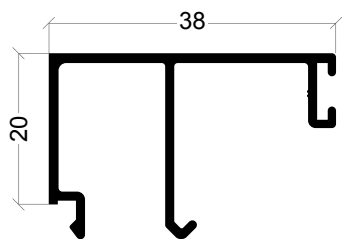

AX-32
Parclose

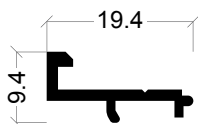

ARi-29
Soutien parclose

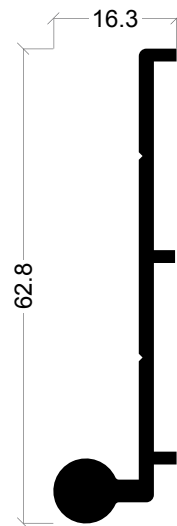

FL-61
Porte soufflet supérieur

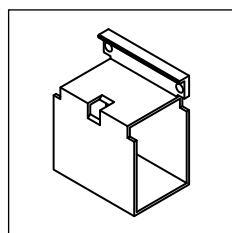

30 00 90 66

Haut traverses

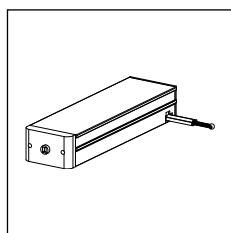

30 00 95 75

Moteur ouverture extérieur
(60 kg - L < 1.4 mt)

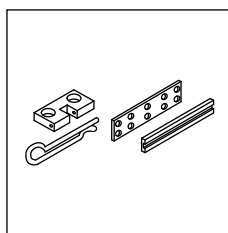

30 00 95 77

Ensemble de
transmission italienne

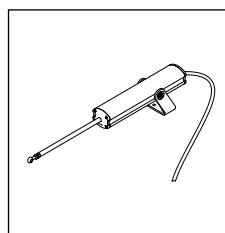

30 15 10 84

Moteur électrique piston
(80 kg - L < 1.5 mt)

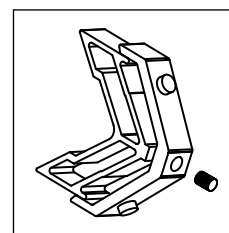

30 90 20 20

Equerre dormant lumière

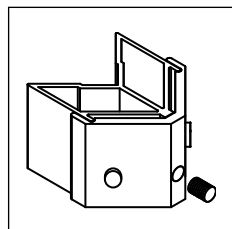

30 90 20 30

Equerre profil ouvrant
lumière

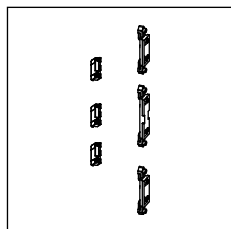

30 90 20 40

Transmission d'ouverture
lumière

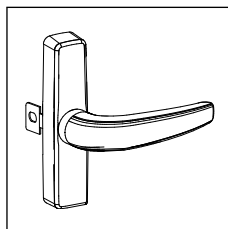

30 90 20 50

Poignée lumière

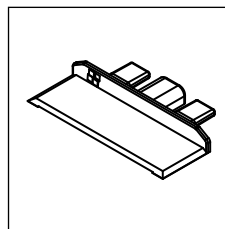

30 90 20 61

Haut de finition Ergolux
noir

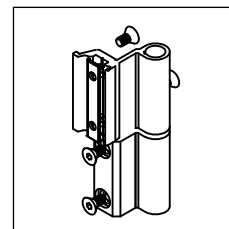

30 92 00 20/21

Charnière C.E. blanc/noir

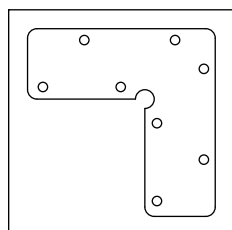

30 92 01 35

Equerre d'alignement

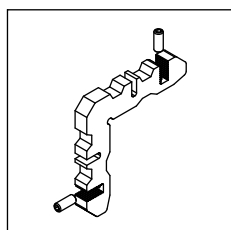

30 96 00 51

Equerre d'alignement 11.9 x
14 avec boulons

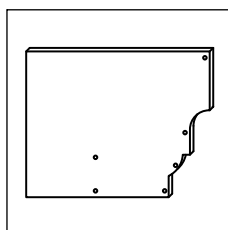

31 90 20 10

Haut pour pignon en
aluminium

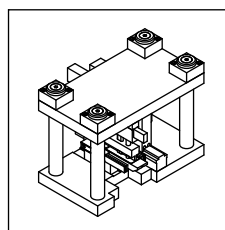

33 23 19 99

Outil XP

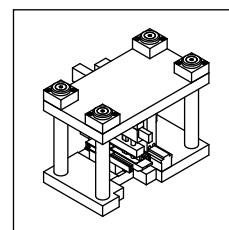

33 96 87 99

Outil equerre intérieur et
extérieur ARi/AKi

Référence	Dessin	Description
30 00 95 01	11	Joint intérieur montant Joint central montant et traverse
30 00 95 03		Joint central (montant et traverse)
30 00 95 05	5	Joint intérieur de traverse
30 00 95 06	7	Joint central montant et traverse
30 00 95 07	13	Joint central montant et traverse
30 00 95 08	15	Joint central montant et traverse
30 00 95 10		Joint de étanchéité traverse FL-42
30 00 95 76	9	Joint central montant et traverse
30 90 20 80		Joint extérieur système Ergolux
30 90 20 90		Joint finition supérieur sectionable
30 96 00 18		Joint pour FL-64 et FL-65

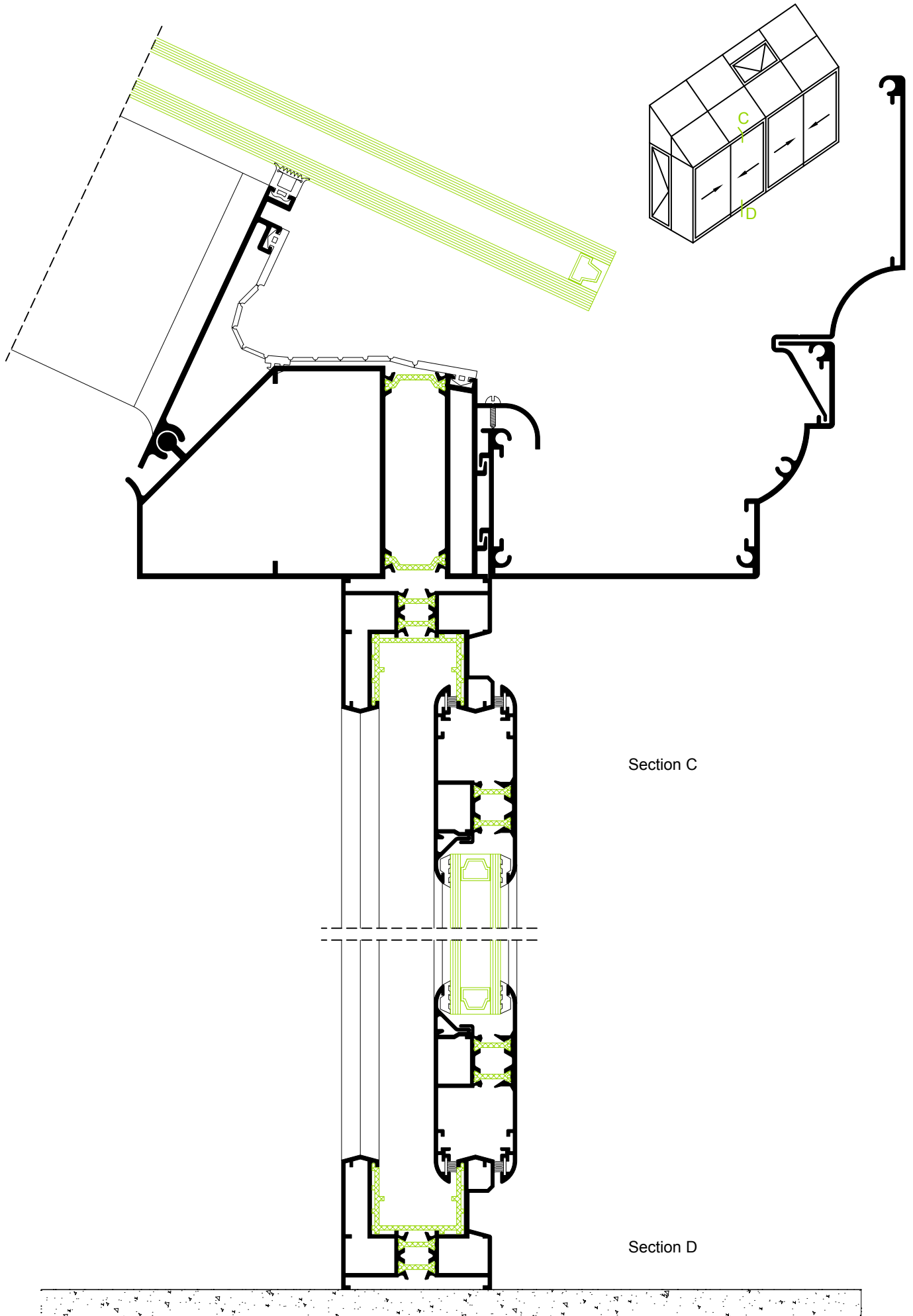

Section C

Section D

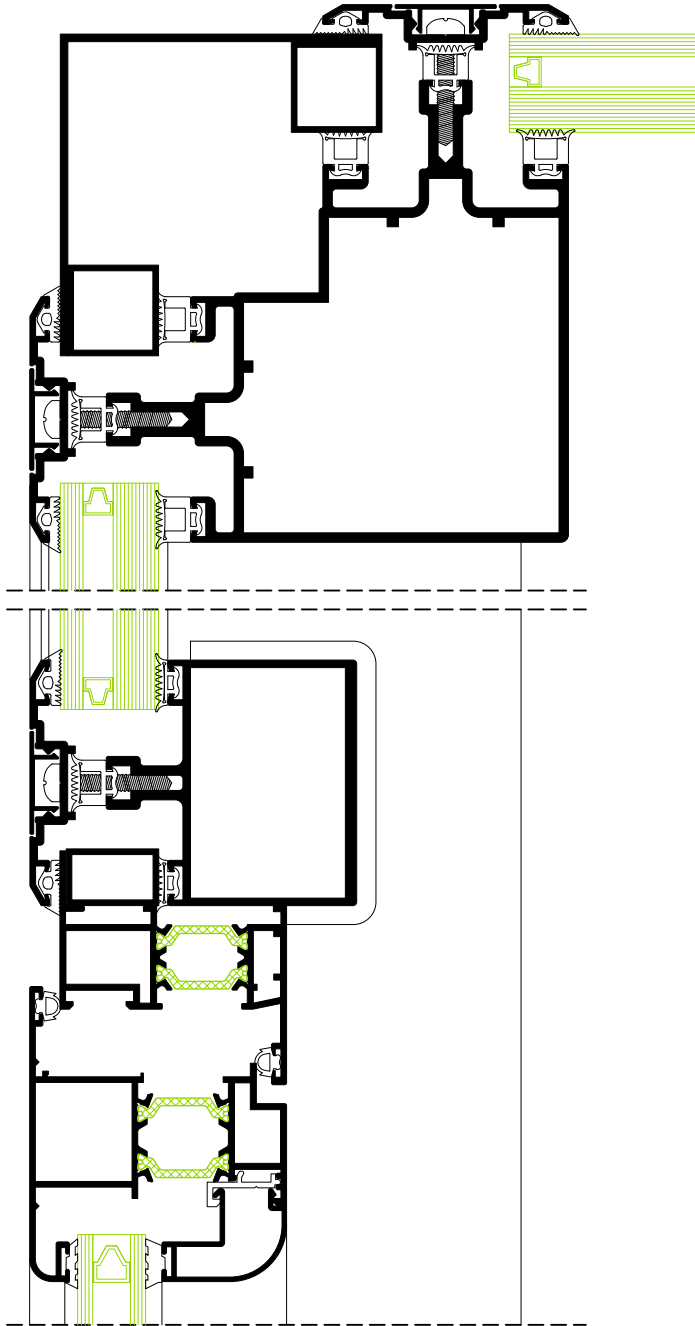

Section E

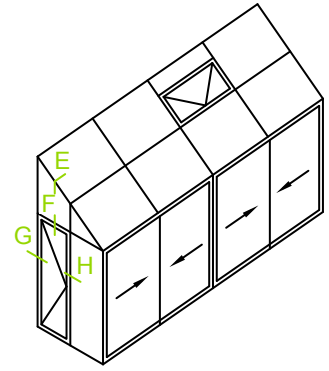

Section F

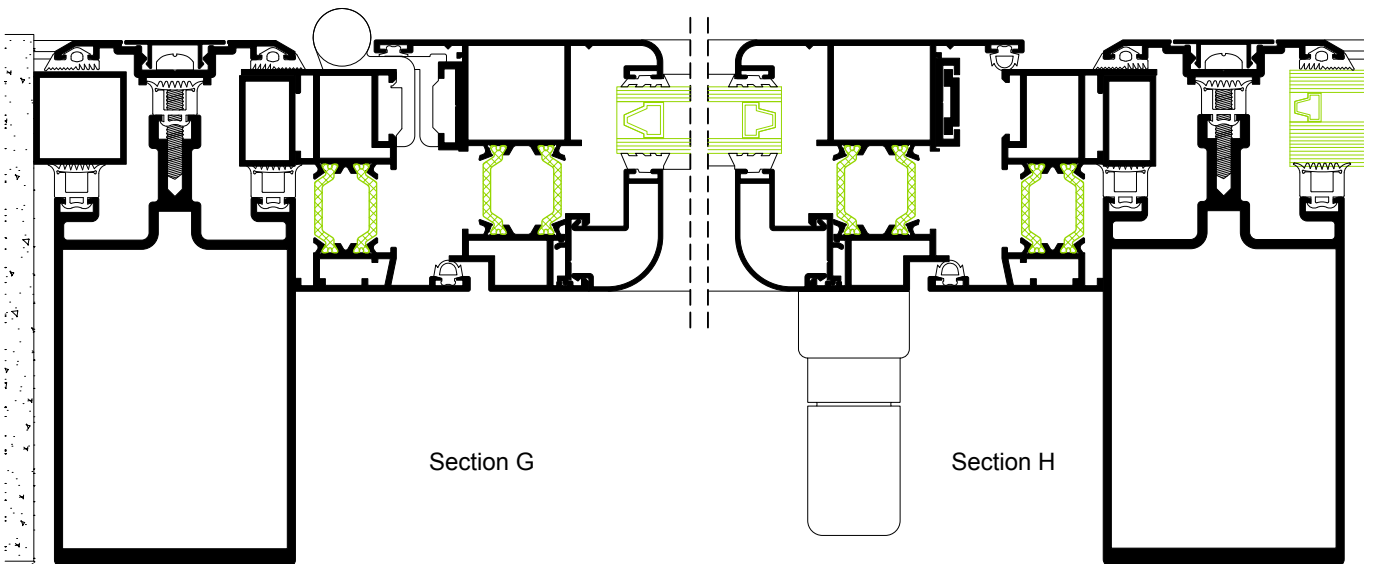

Section G

Section H

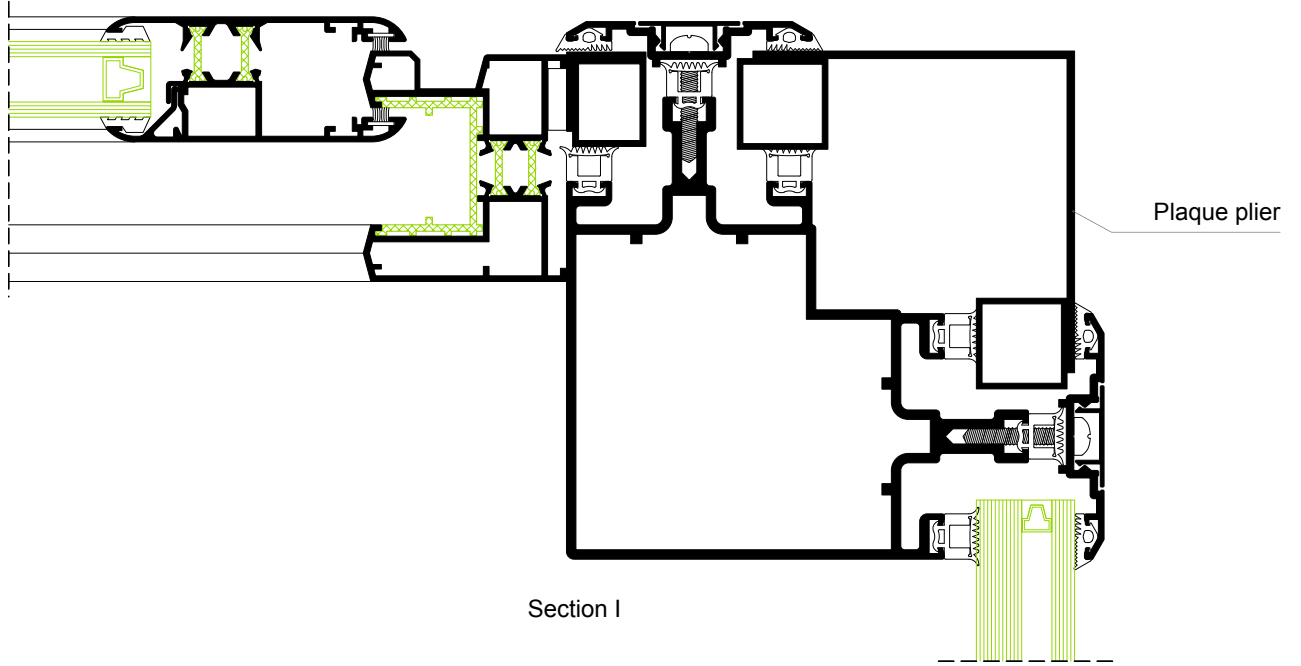
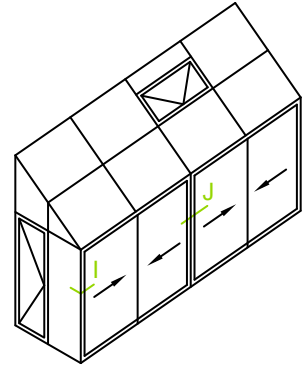

432

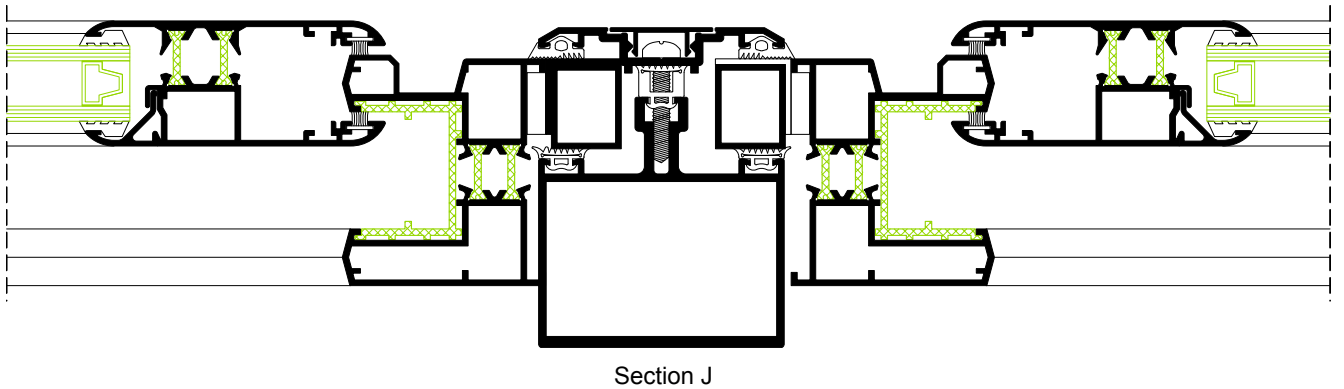

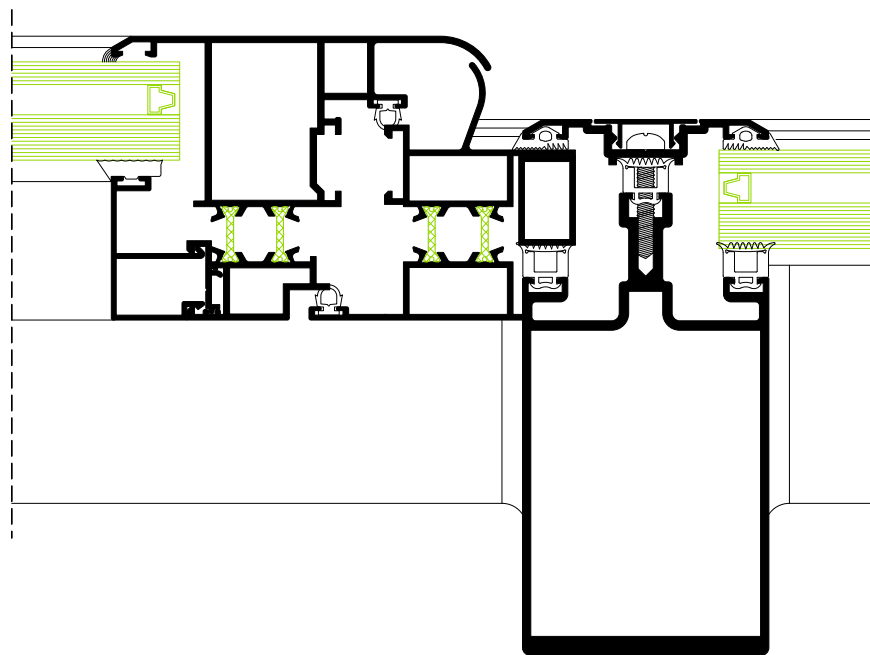
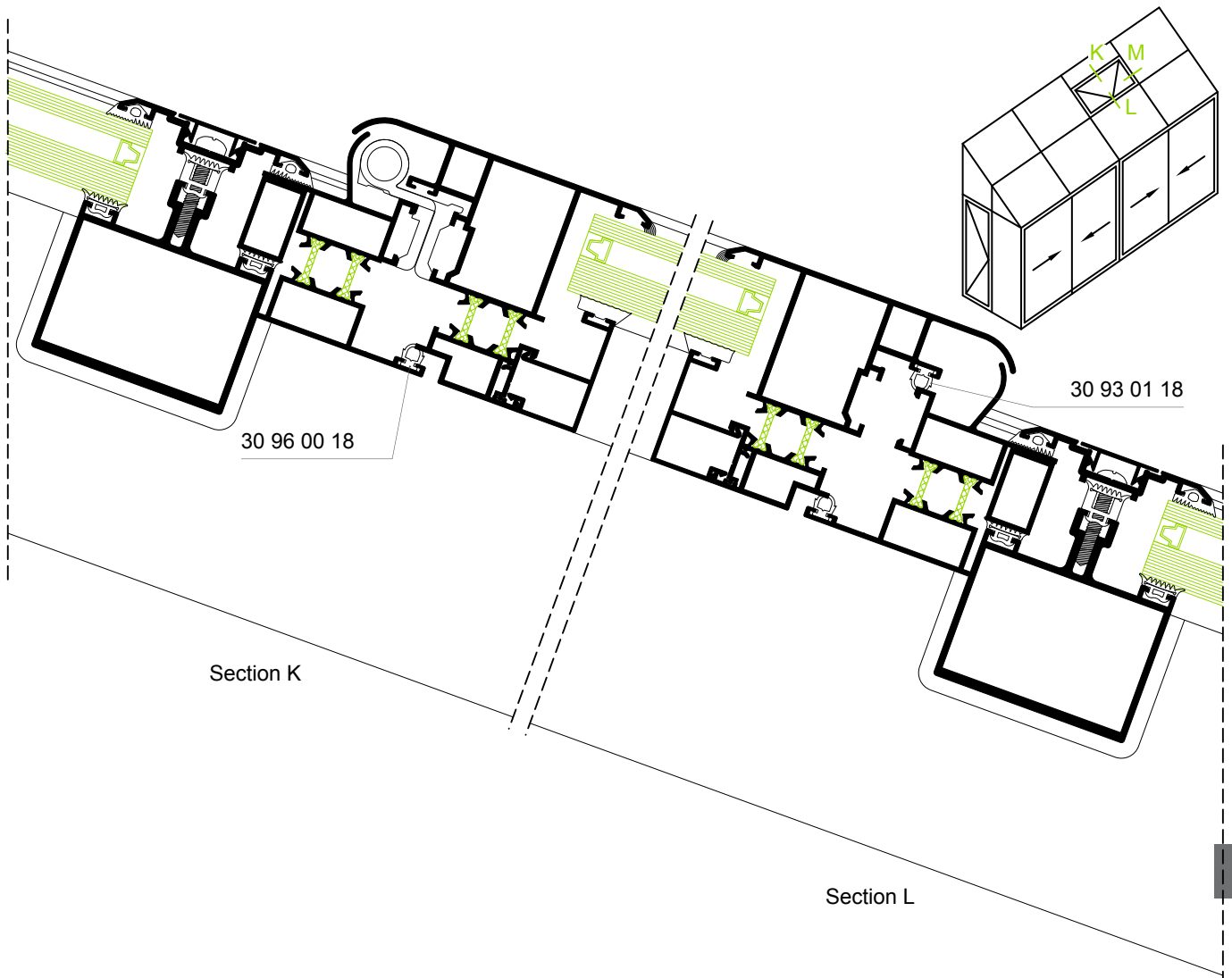

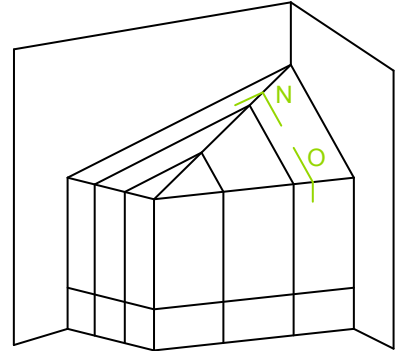

434

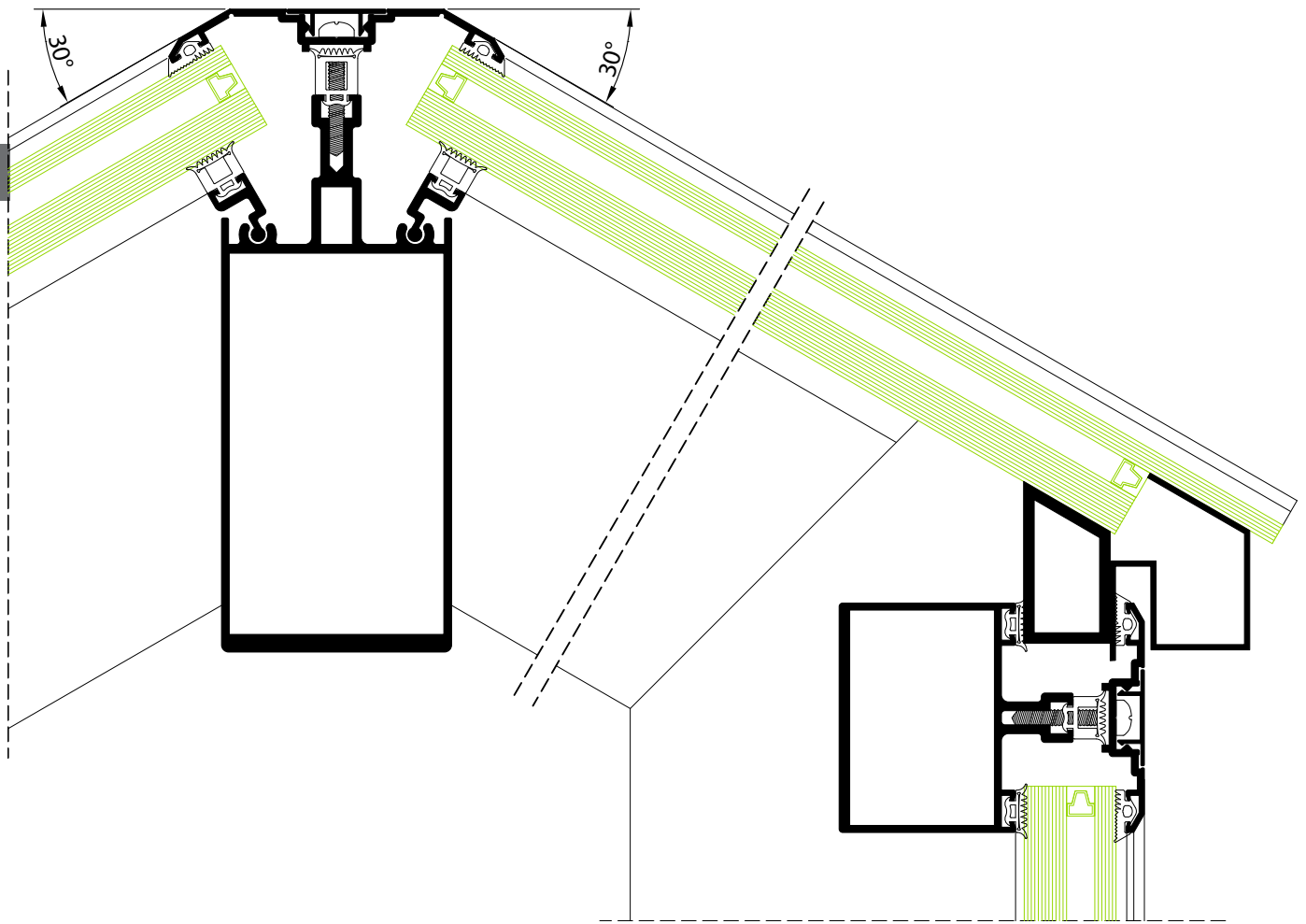

Section N

Section O

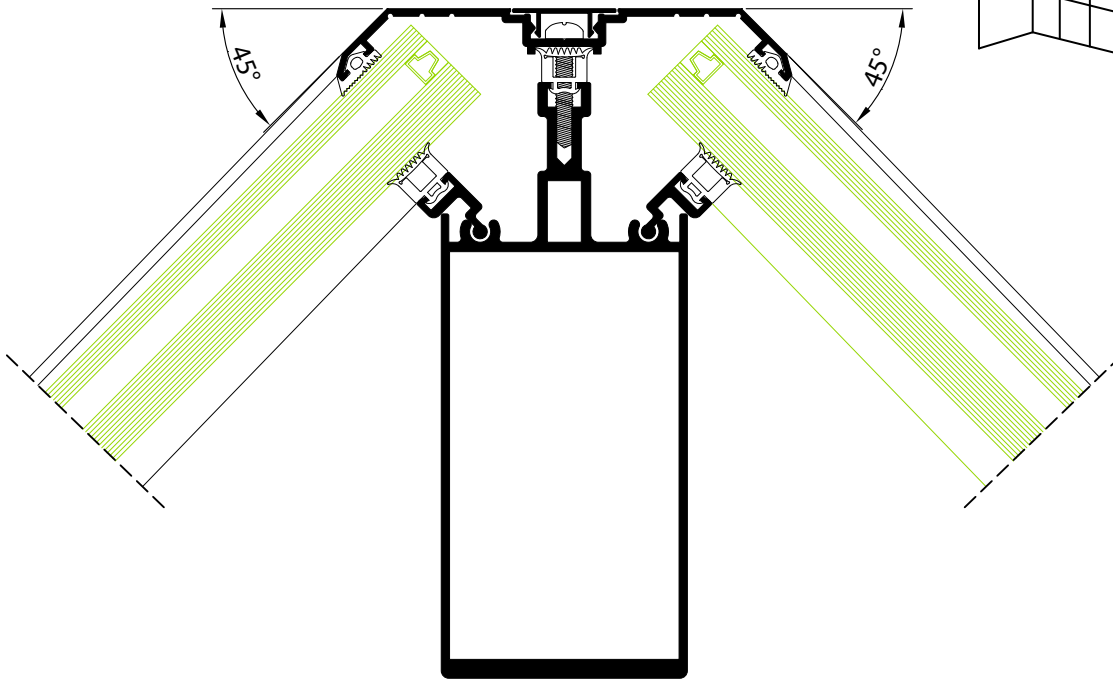
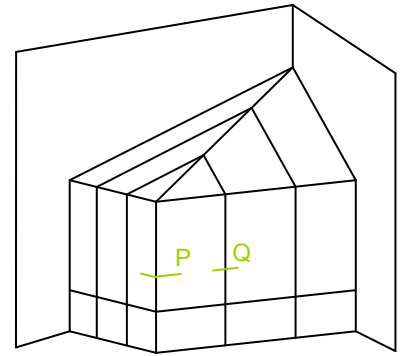

Section P

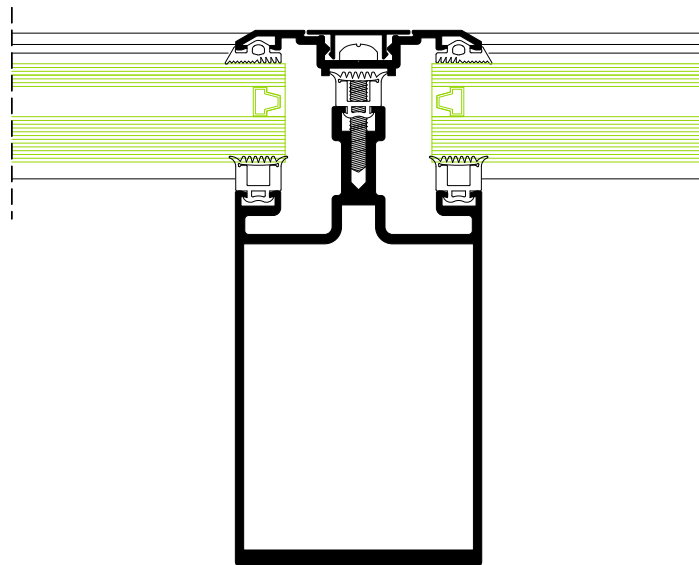

Section Q

436

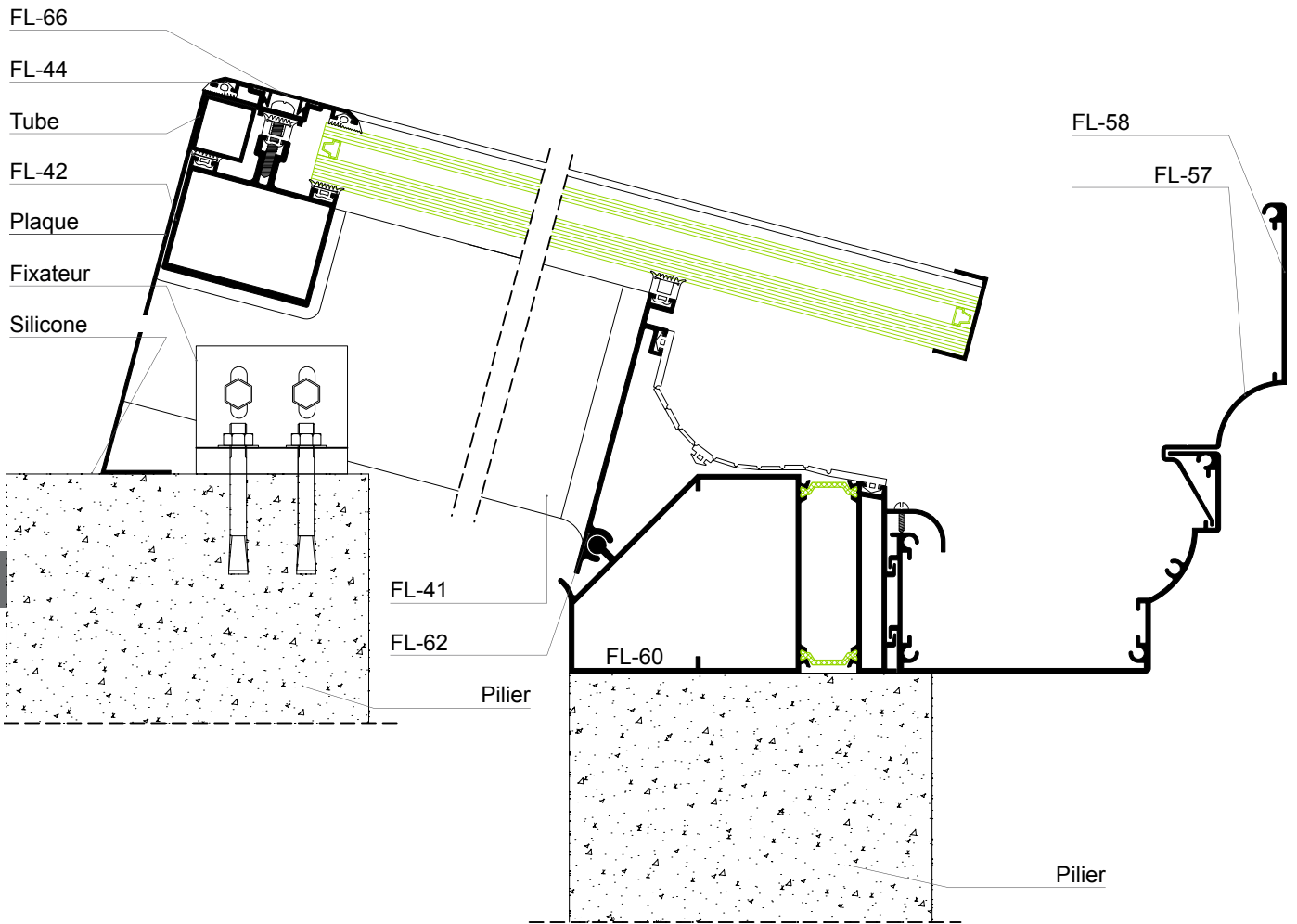

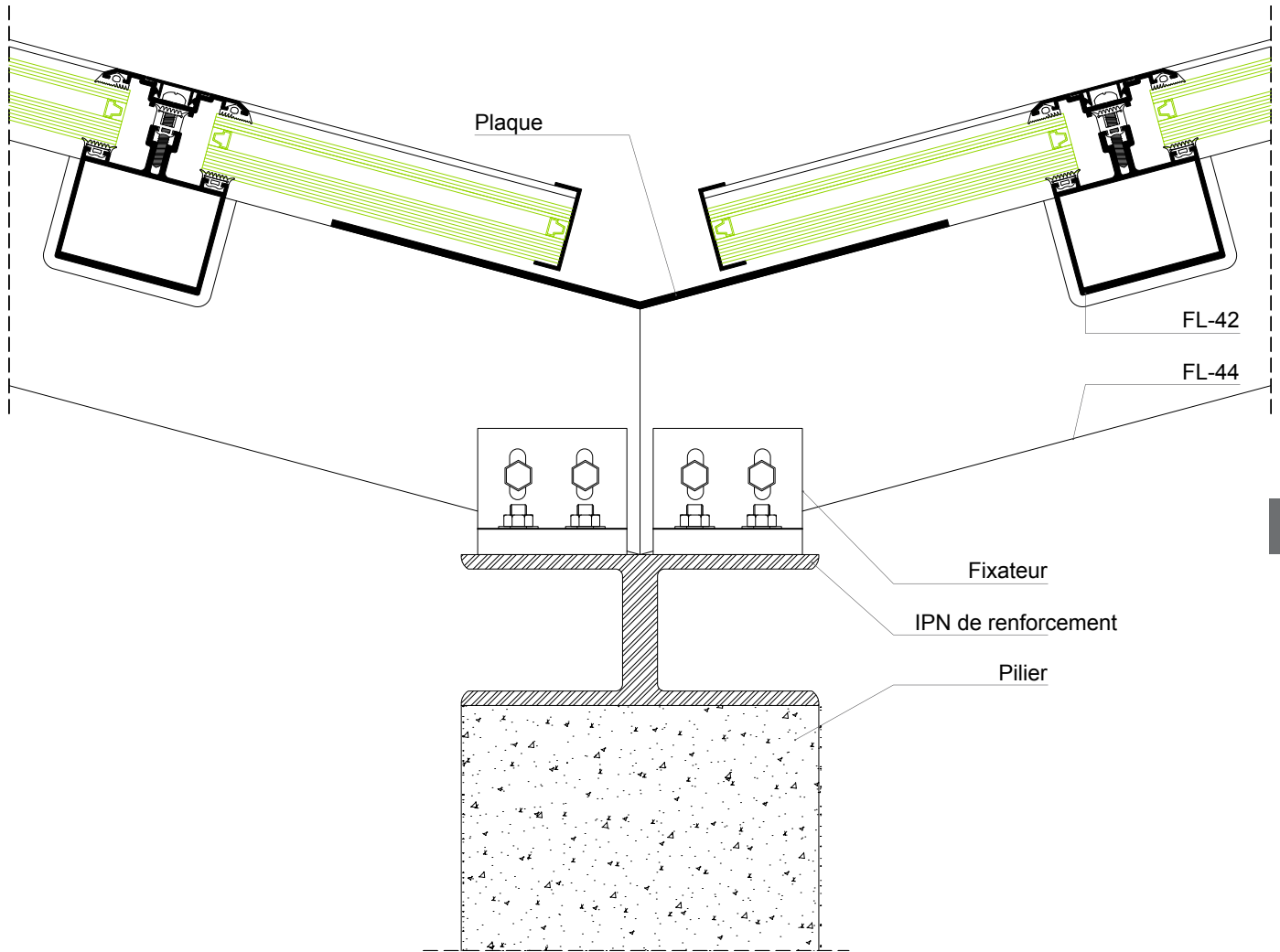

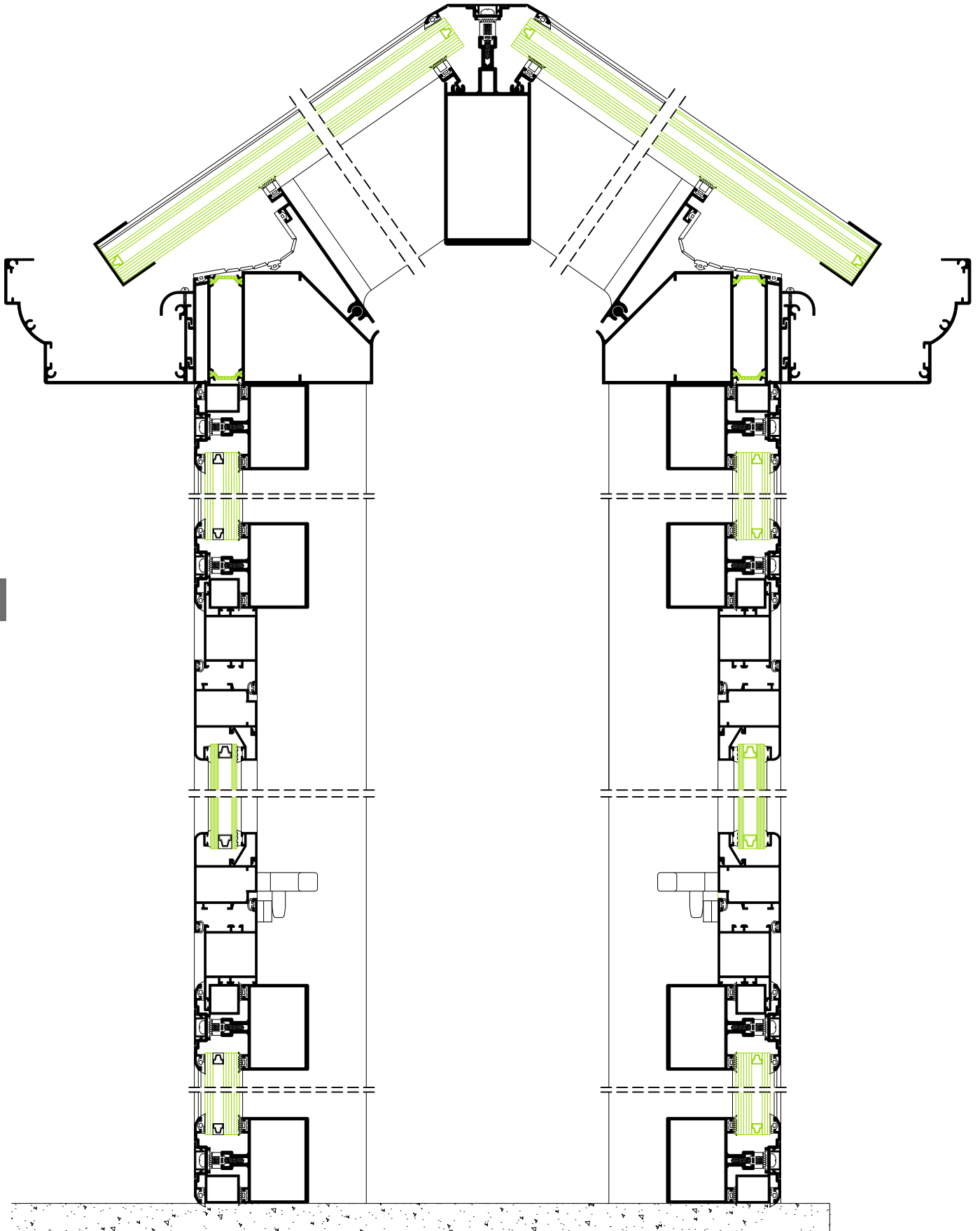

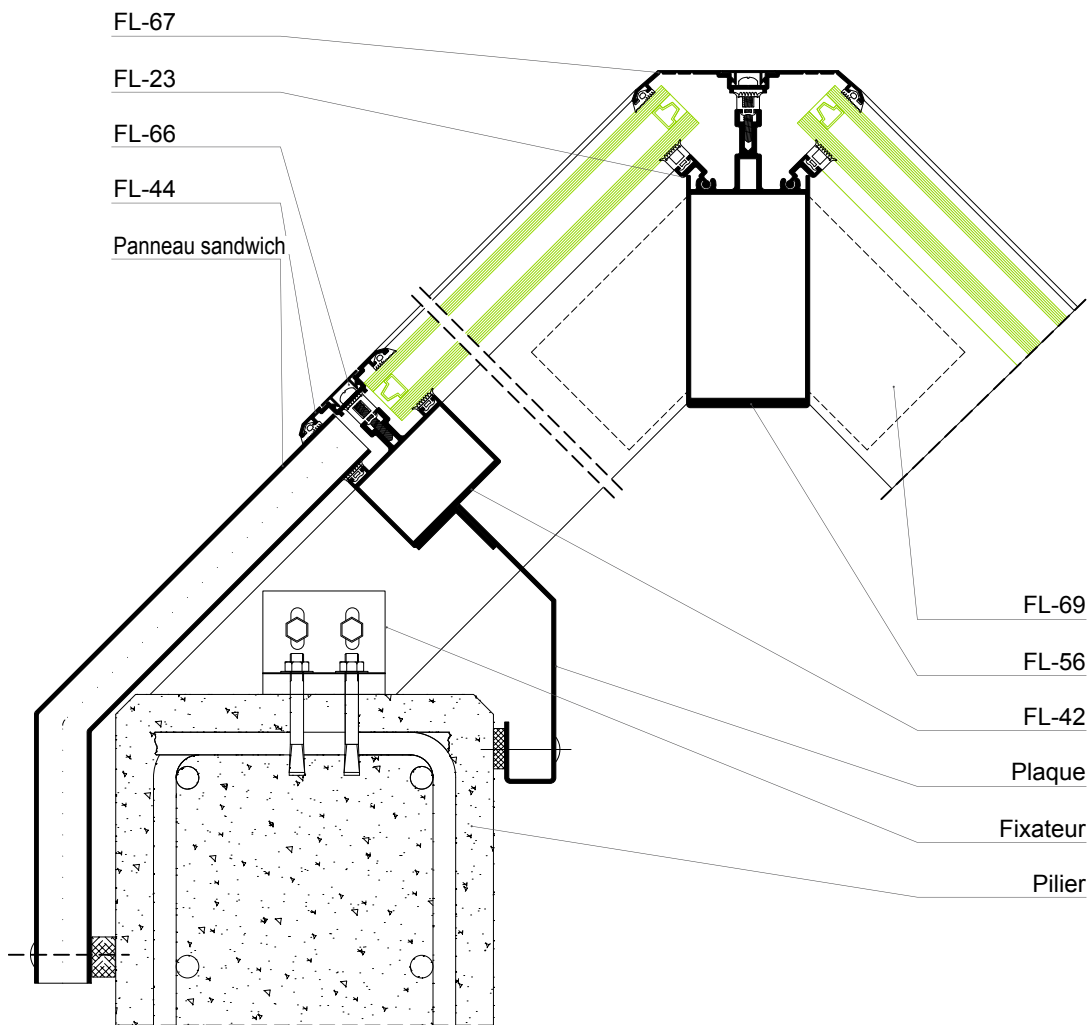

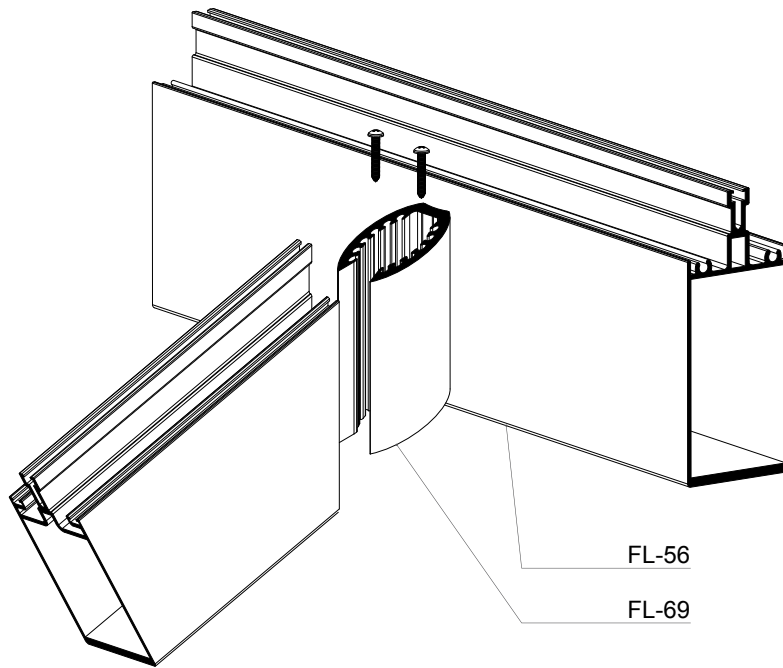

Détail I

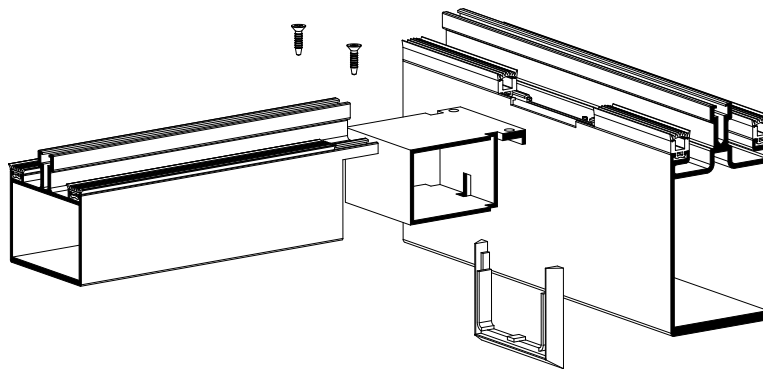

Détail II

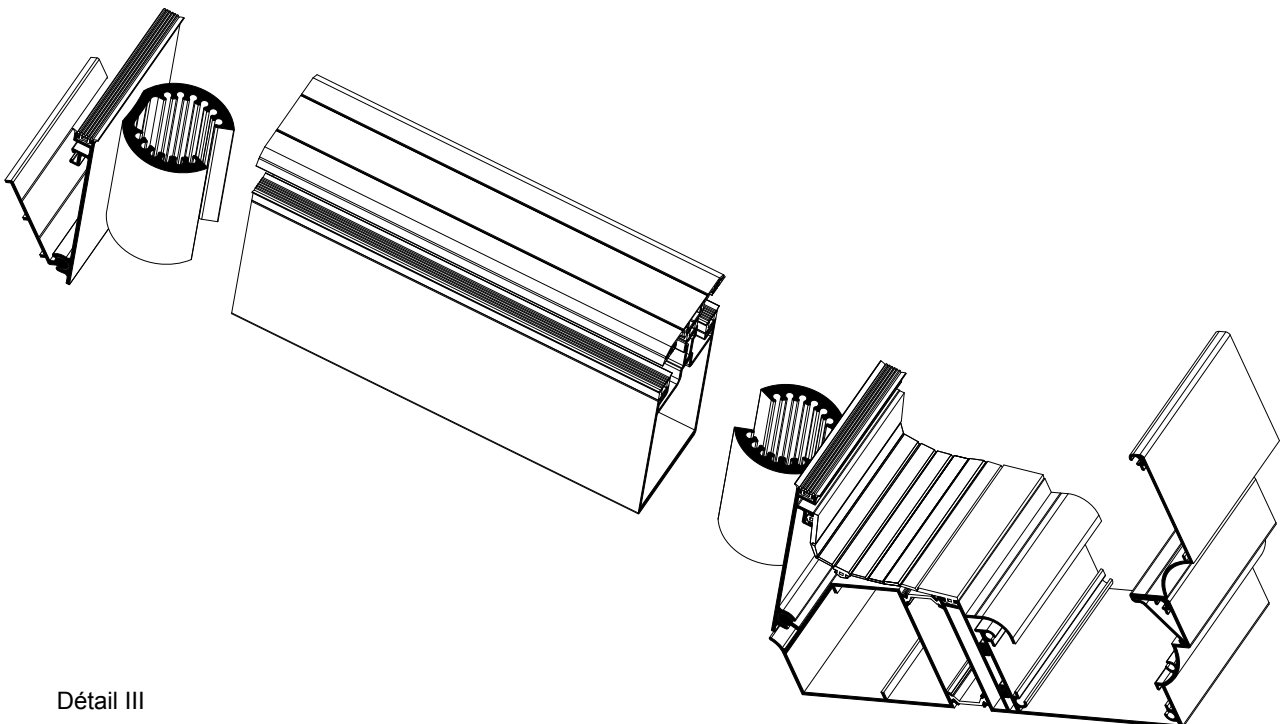

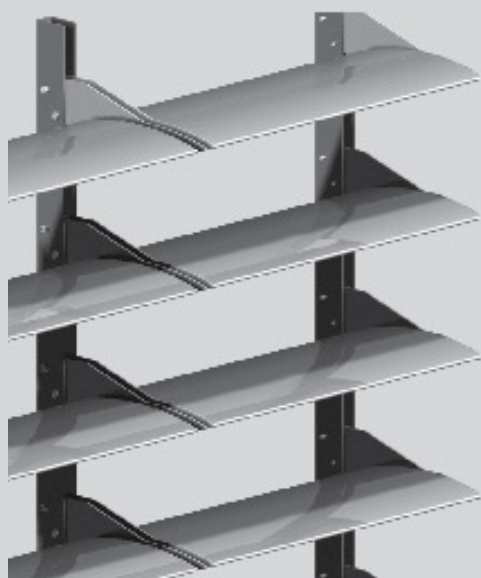
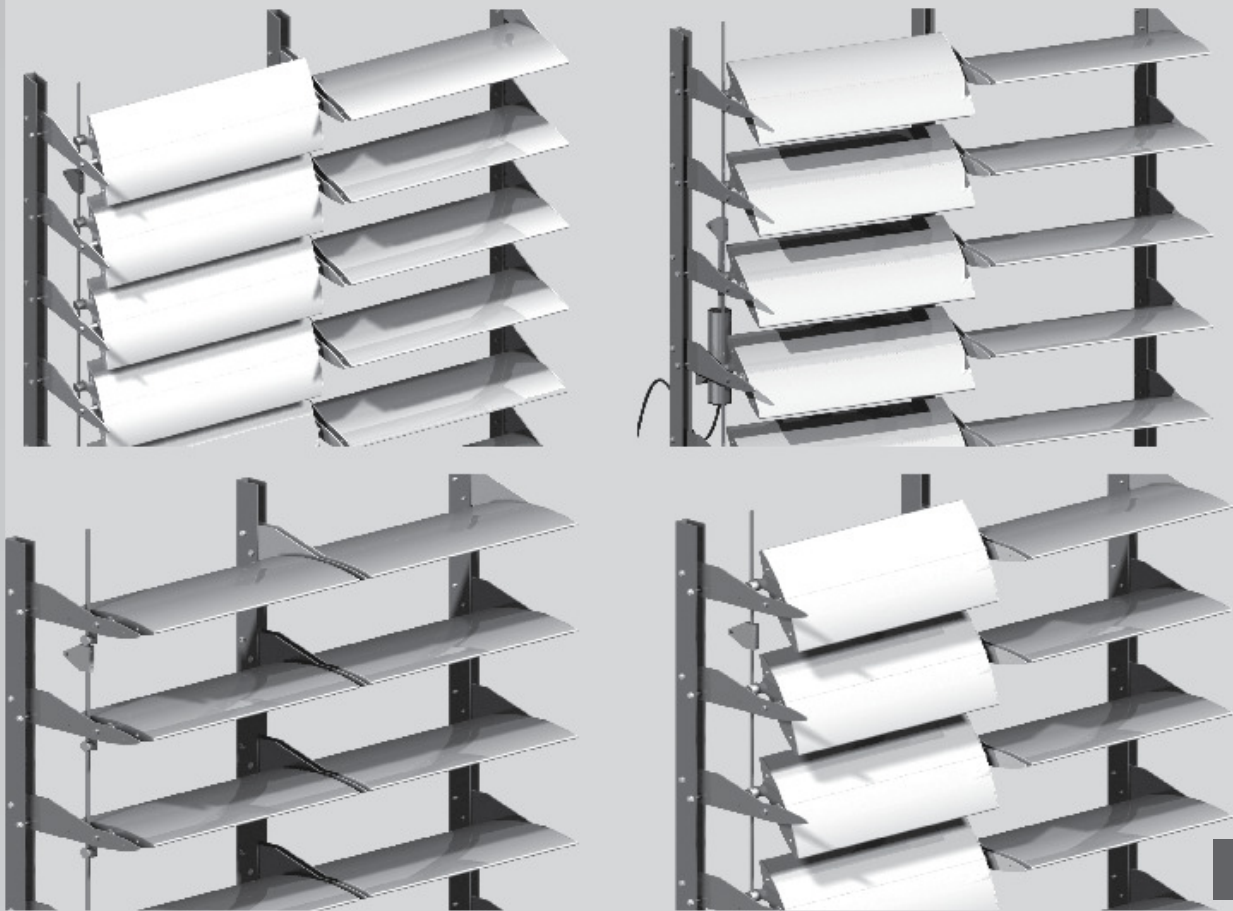

**Brise
Soleil**

Brise Soleil

Caractéristiques

Systèmes d'aluminium préparé pour assemblage en façades avec l'objectif de faire l'effet de brise soleil présentant en même temps une forme esthétique.

Permettent de assembler dans des suivants formes:

- lames fixes;
- lames amovibles.

Les systèmes de lames amovibles permettent un contrôle sur sa orientation par un mécanisme manuel ou motorisé en que les deux peuvent être contrôlés à distance. Les lames brise soleil ils existent avec les sections transversales de 120, 165, 250 et 345 mm avec une épaisseur moyenne des profils d'aluminium de 1.5 mm.

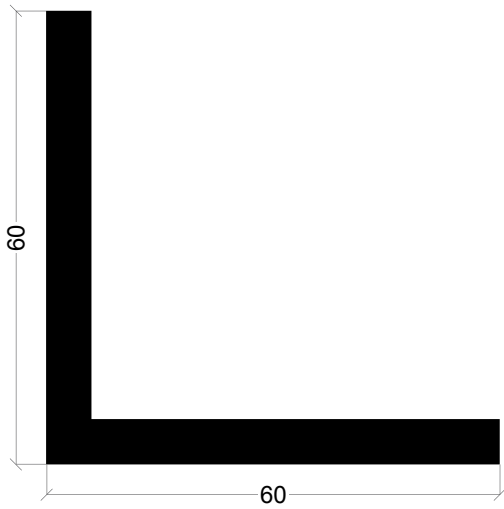

L-25

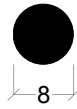

G-01

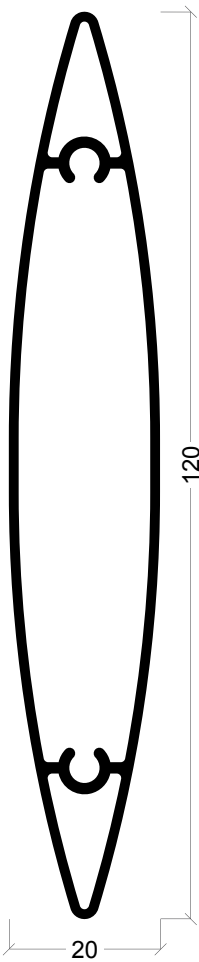

Z-58

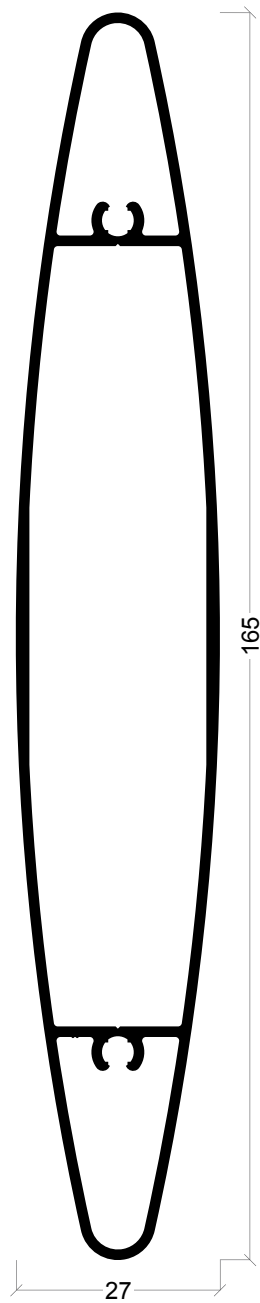

Z-68

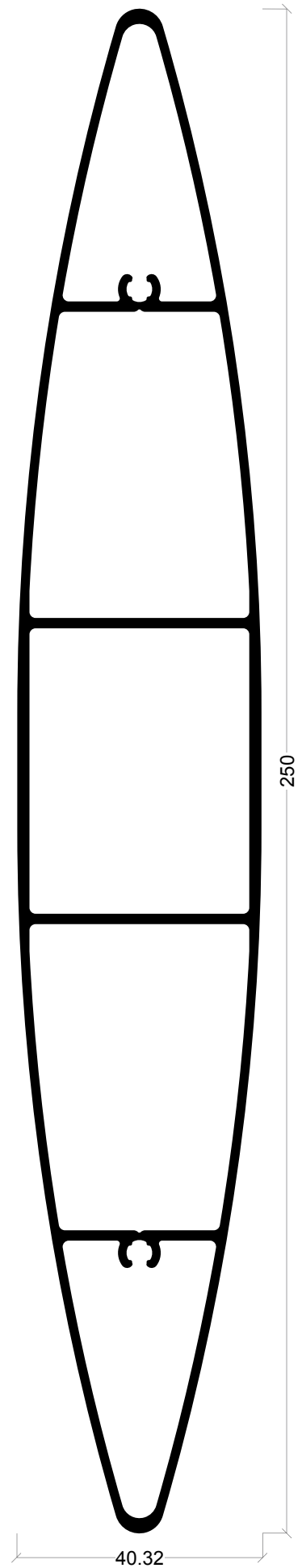

Z-62

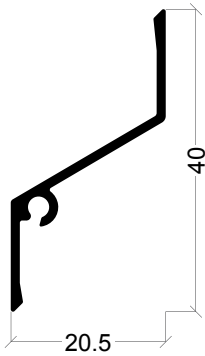

Z-26

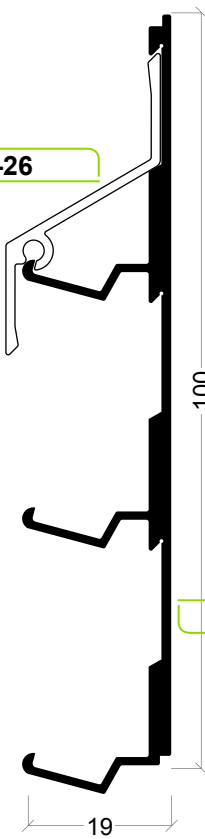

Z-25 + Z-26

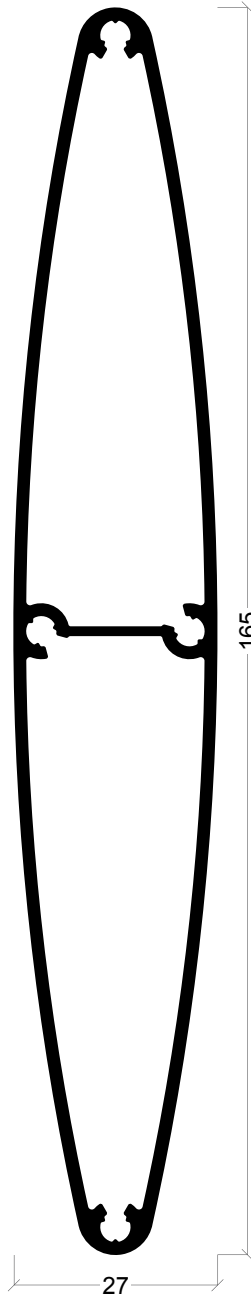

Z-64 (lame fixe)

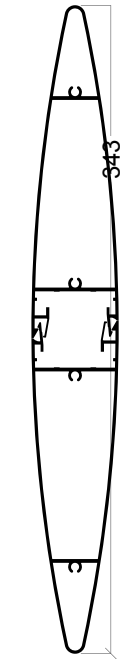

Z-65 + Z-65

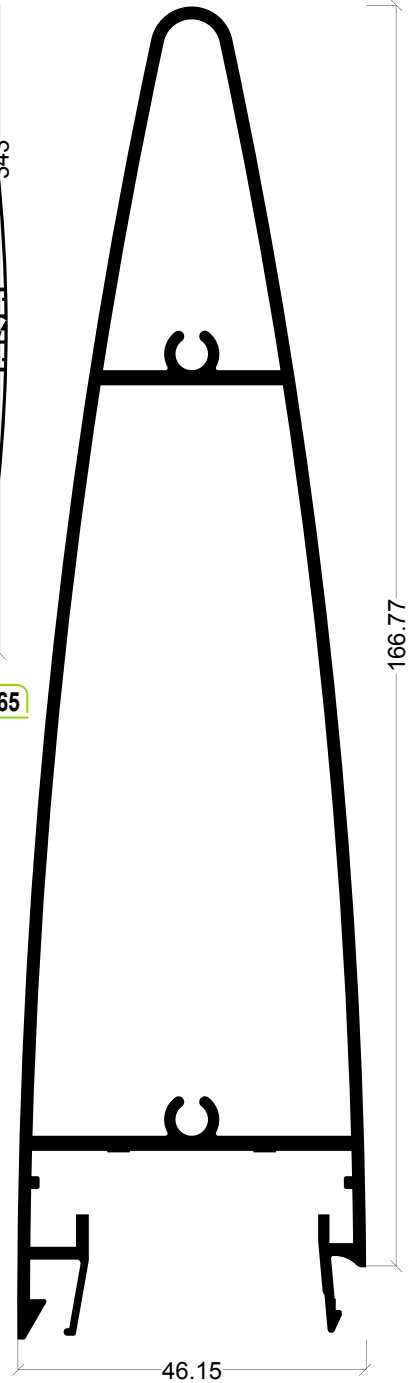

Z-65

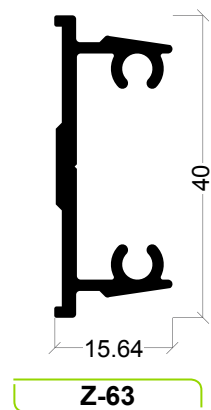
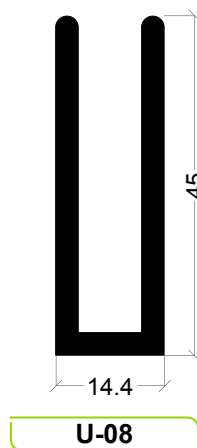
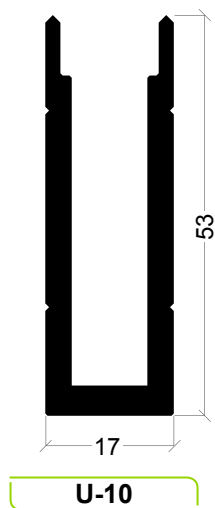
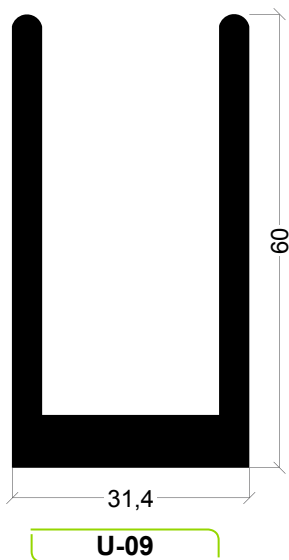
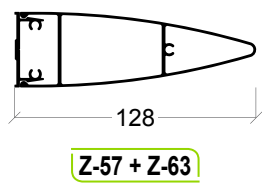
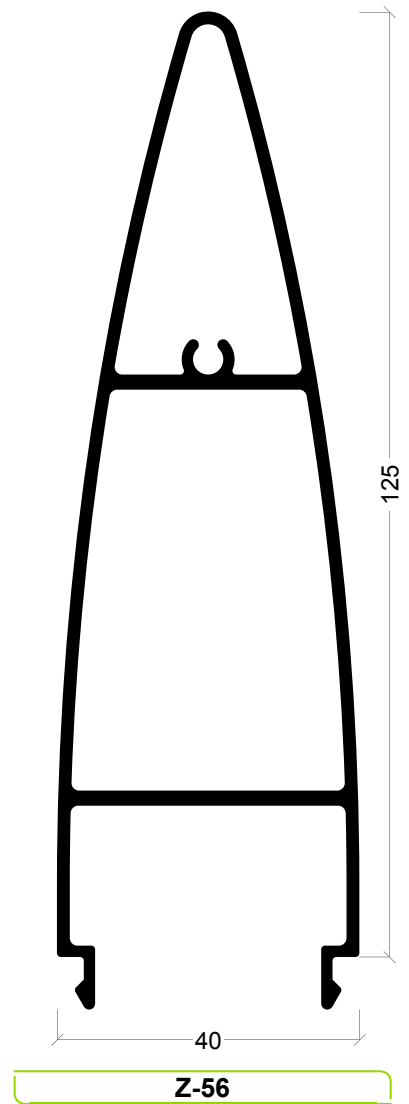
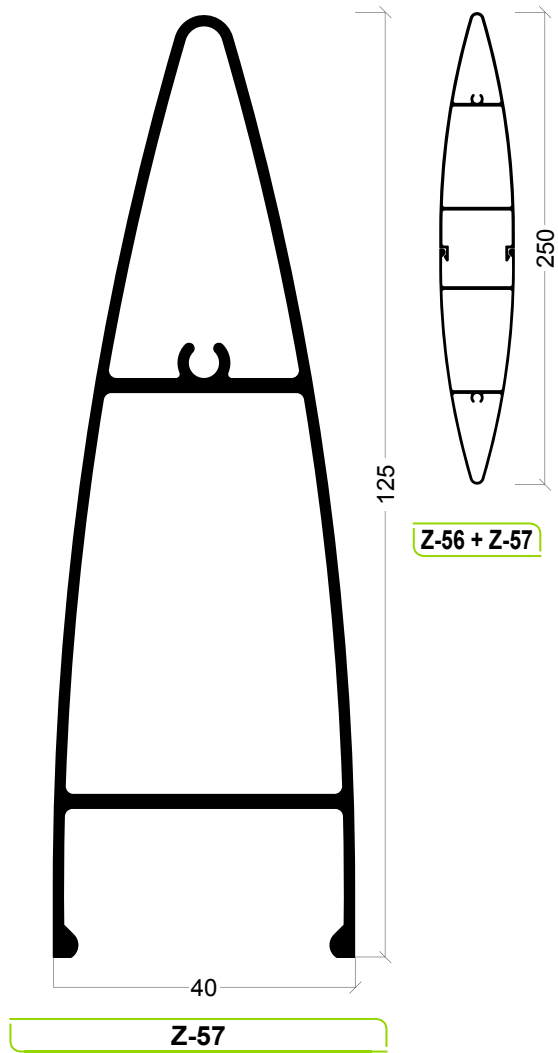

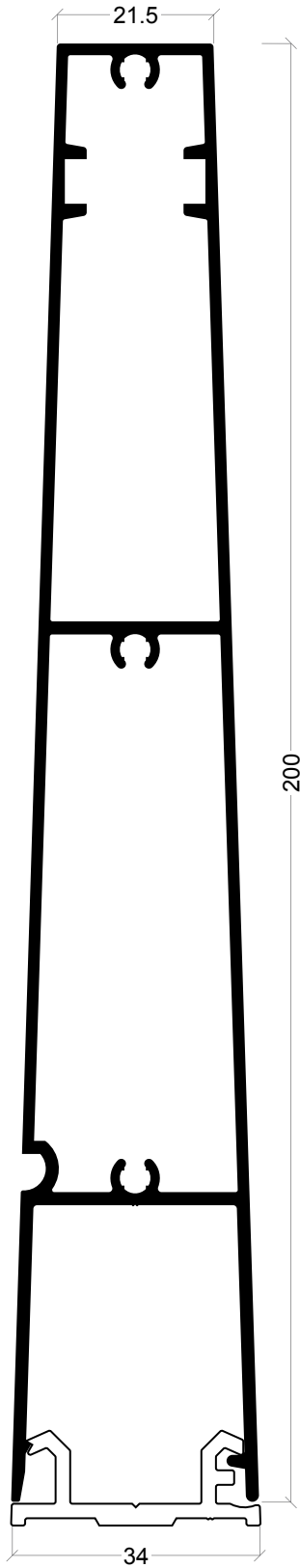

Z-67

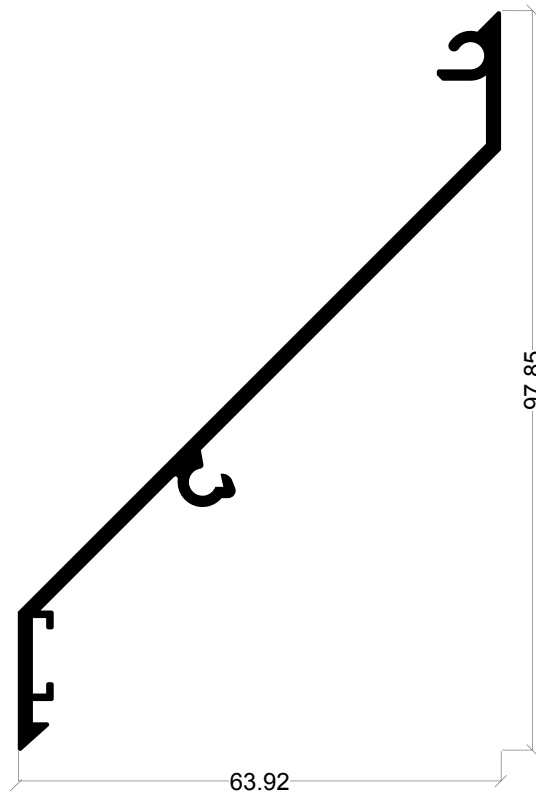

Z-24

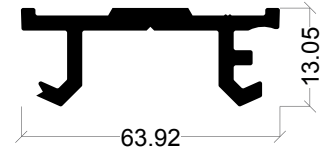

Z-66

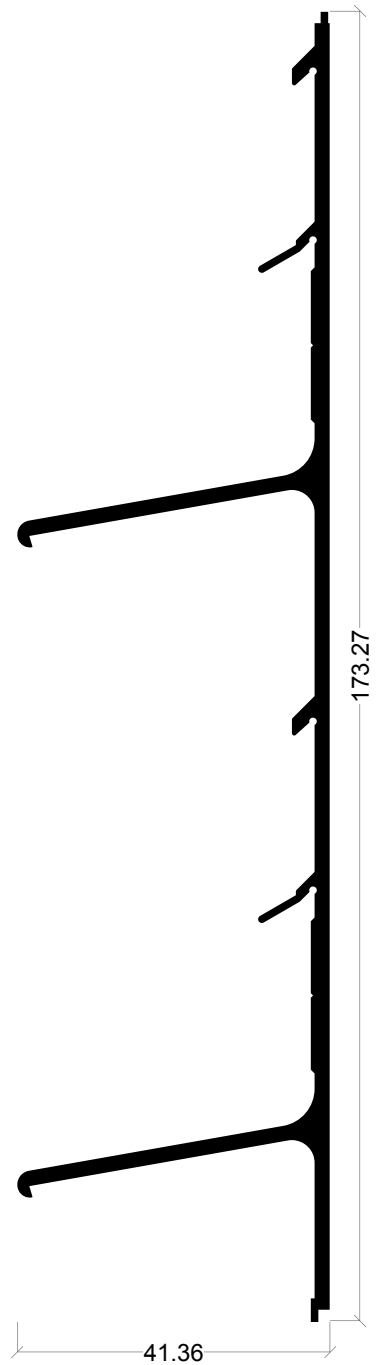

Z-23

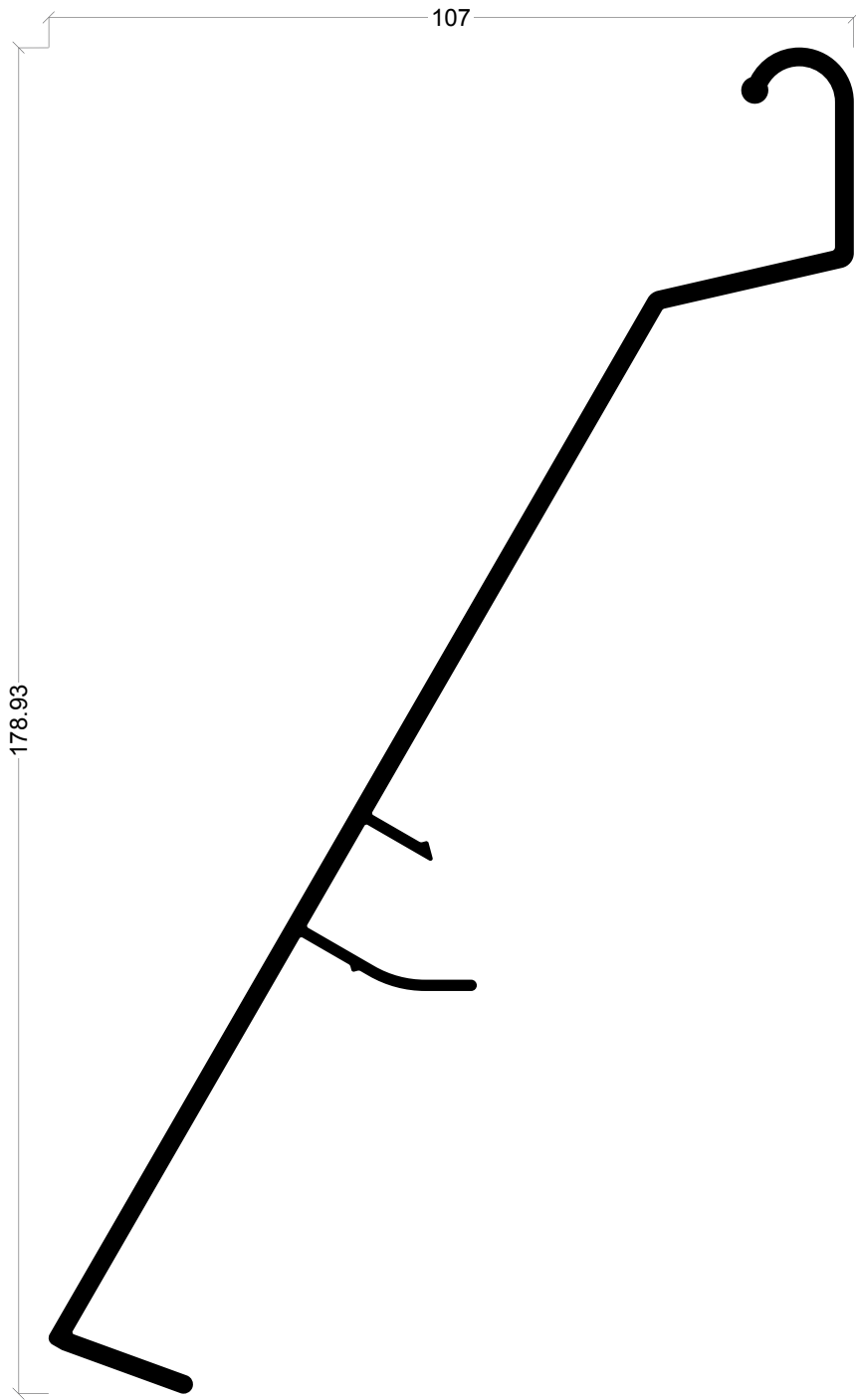

Z-43

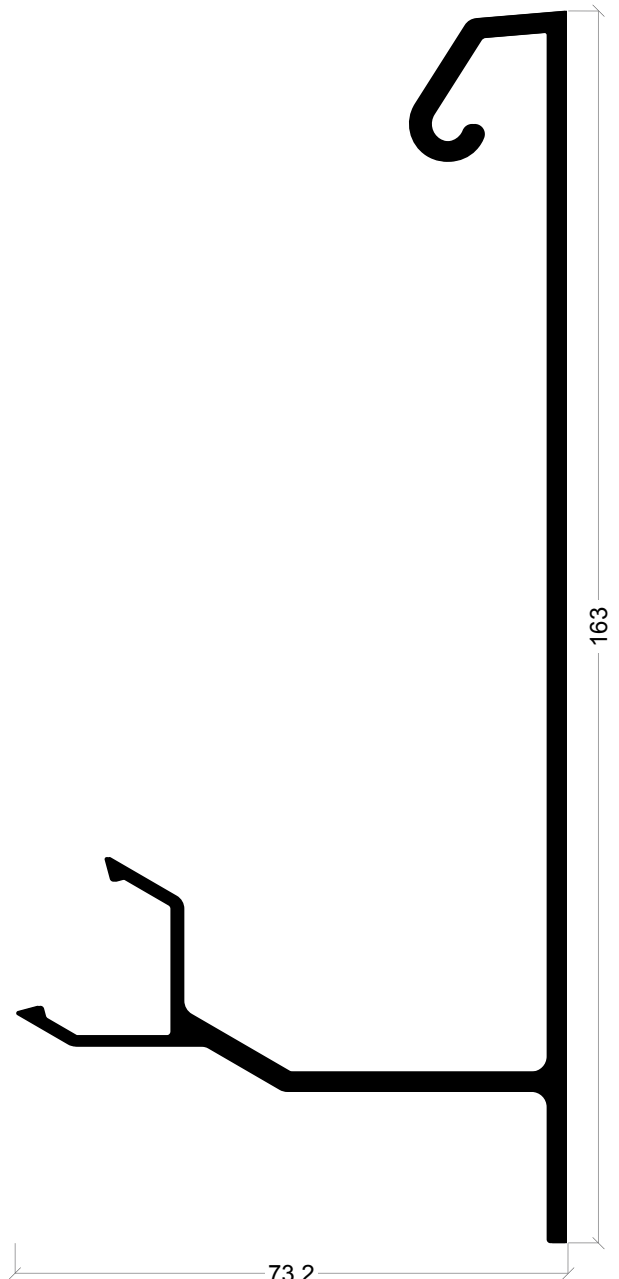

Z-42

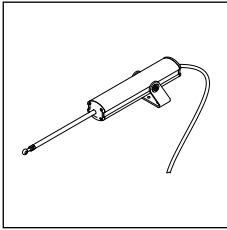

30 15 10 84
Moteur électrique

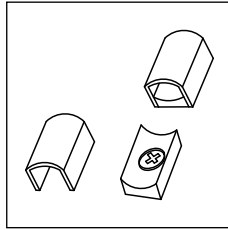

30 15 11 00
Fixateur tube commande manuelle

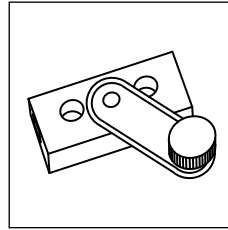

30 15 11 02
Manivelle commande manuelle

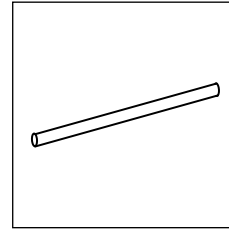

30 15 11 03
Tube aluminium (3m)

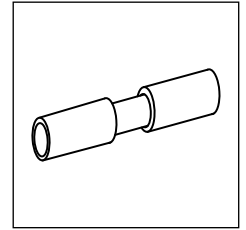

30 15 11 04
Union de tubes

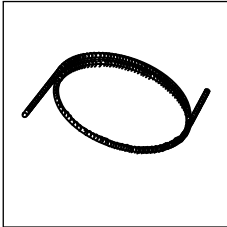

30 15 11 12
Câble commande manuelle

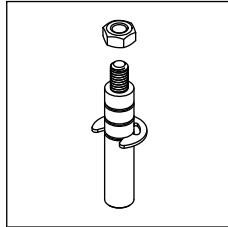

30 15 11 24
Axe supérieur lame (Z-58 ou Z-68)

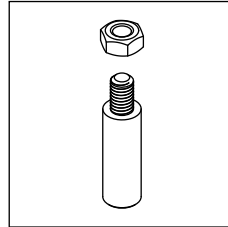

30 15 11 29
Axe inférieur (Z-58 ou Z-68)

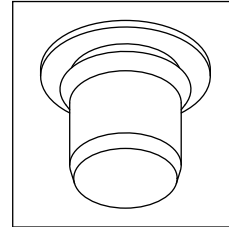

30 15 11 30
Casquette inférieur (Z-58 ou Z-68)

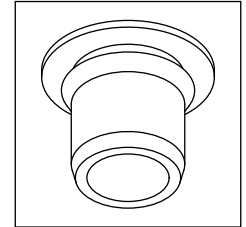

30 15 11 31
Casquette supérieur (Z-58 ou Z-68)

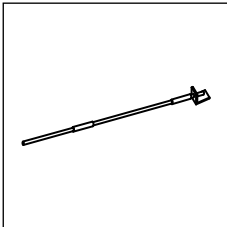

30 15 11 36
Actionneur télescopique

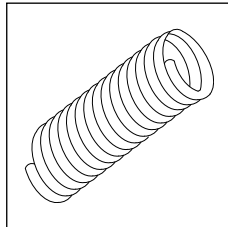

30 15 11 96
Ressort fin de course

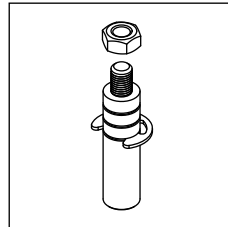

30 15 12 24
Axe supérieur lame (Z-62 ou Z-65)

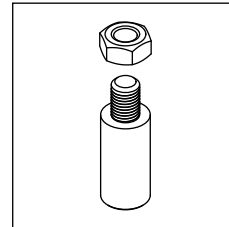

30 15 12 29
Axe inférieur lame (Z-62 ou Z-65)

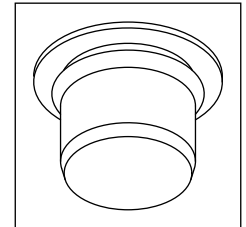

30 15 12 30
Casquette inférieur lame (Z-62 ou Z-65)

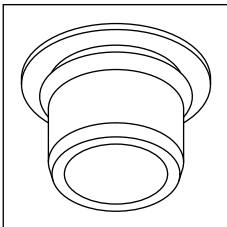

30 15 12 31
Casquette supérieur lame (Z-62 ou Z-65)

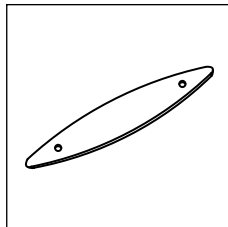

31 15 00 40
Haut simple 250 mm

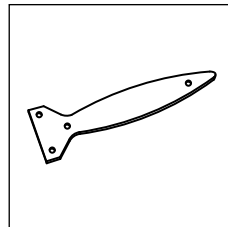

31 15 00 42
Haut fixation 120 mm

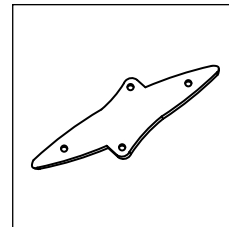

31 15 00 63
Haut fixation central 120 mm

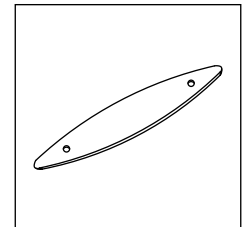

31 15 00 67
Haut simple 120 mm

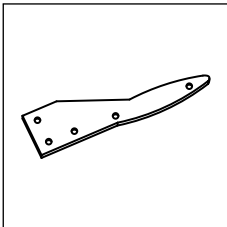

31 15 00 71
Haut fixation allongé 120 mm

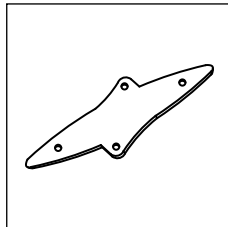

31 15 00 75
Haut fixation central 250 mm

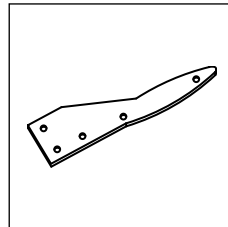

31 15 00 79
Haut fixation allongé 250 mm

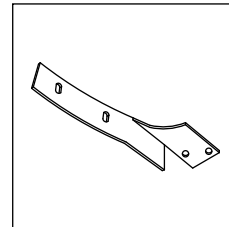

31 15 00 84
Soutien central 250 mm droit

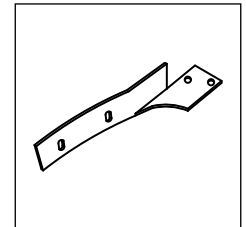

31 15 00 85
Soutien central 250 mm gauche

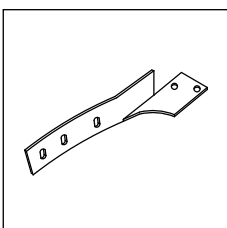

31 15 00 86 / 87
Soutien central 343 mm gauche / droit

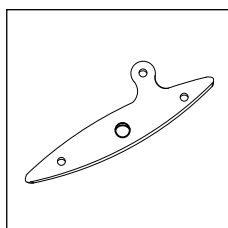

31 15 01 01
Haut latéral lame ouvrant 120 mm

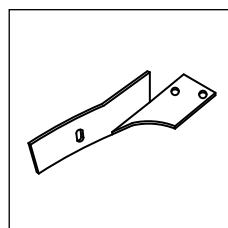

31 15 01 08
Soutien central 120 mm gauche

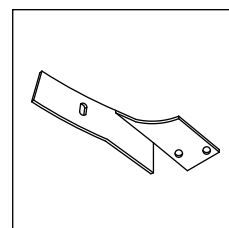

31 15 01 09
Soutien central 120 mm droit

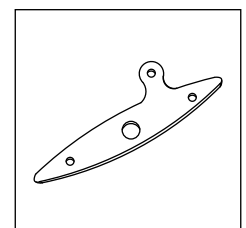

31 15 01 12
Haut latéral lame ouvrant 250 mm

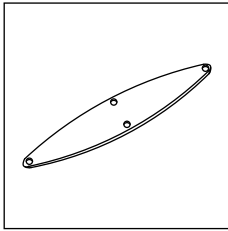

31 15 01 15

Haut simple 165 mm
(Z-64)

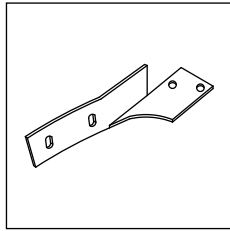

31 15 01 16

Soutien central 165 mm
gauche

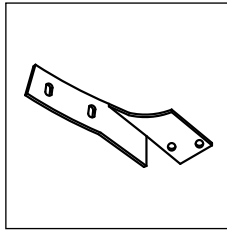

31 15 01 17

Soutien central 165 mm
droit

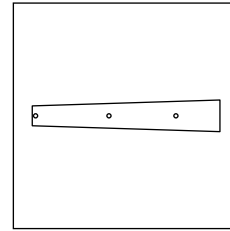

31 15 01 35

Haut pour lame Z-67

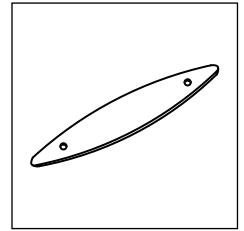

31 15 01 36

Haut simple 343 mm

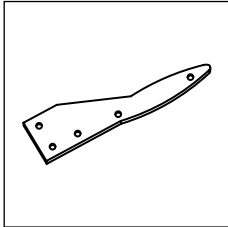

31 15 01 40

Haut fixation allongé
343 mm

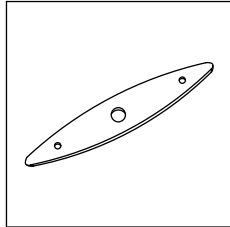

31 15 01 42

Haut latéral lame ouvrant
120 mm

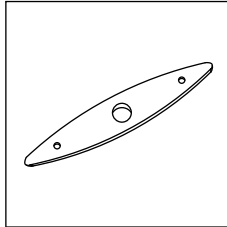

31 15 01 43

Haut latéral lame ouvrant
343 mm

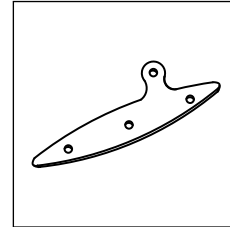

31 15 01 44

Haut latéral lame ouvrant
343 mm

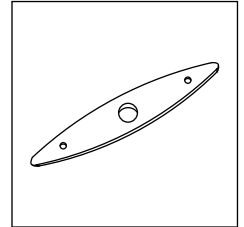

31 15 01 46

Haut latéral lame ouvrant
250 mm

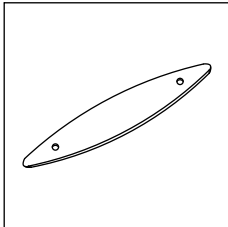

31 15 01 51

Haut simple 165 mm
(Z-68)

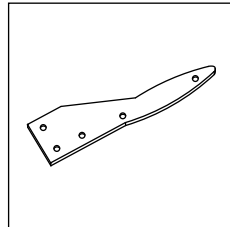

31 15 01 56

Haut fixation allongé 165
mm (Z-68)

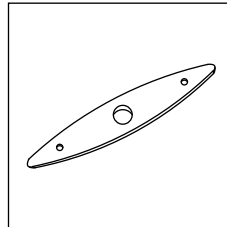

31 15 01 60

Haut latéral lame ouvrant
165 mm (Z-68)

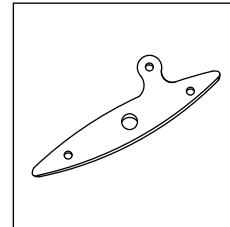

31 15 01 61

Haut latéral lame ouvrant
avec rebord 165 mm (Z-68)

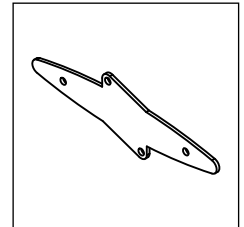

31 15 01 62

Haut fixation central
165mm (Z-68)

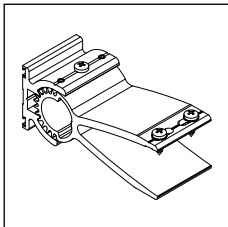

31 15 02 00

Ensemble griffes Z-58
(brut)

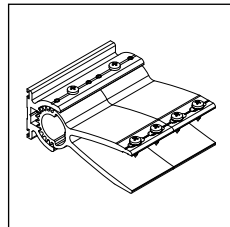

31 15 02 01

Ensemble griffes doubles
Z-58 (brut)

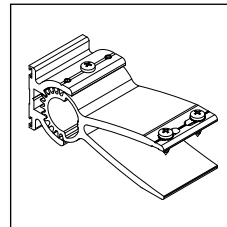

31 15 02 10

Ensemble griffes
Z-64/Z-68 (brut)

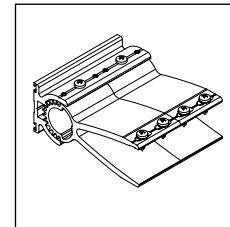

31 15 02 11

Ensemble griffes doubles
Z-64/Z-68 (brut)

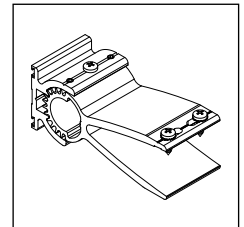

31 15 02 20

Ensemble griffes Z-62
(brut)

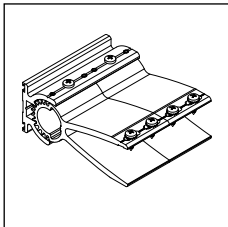

31 15 02 21

Ensemble griffes doubles
Z-62 (brut)

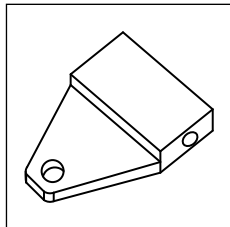

31 15 11 25

Connexion système
électrique ou manuelle

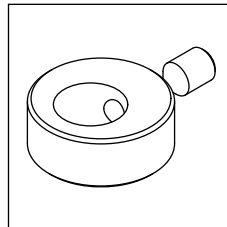

31 15 11 26

Anneau frein lame (Z-58
ou Z-68)

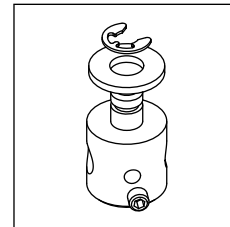

31 15 11 28

Axe de connexion (Z-58
ou Z-68)

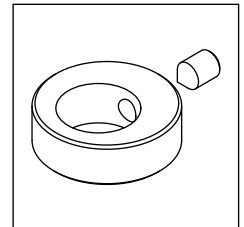

31 15 12 26

Rondelle frein lame
(Z-62 u Z-65)

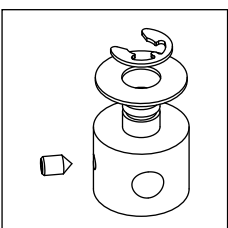

31 15 12 28

Axe connexion lame
(Z-62 ou Z-65)

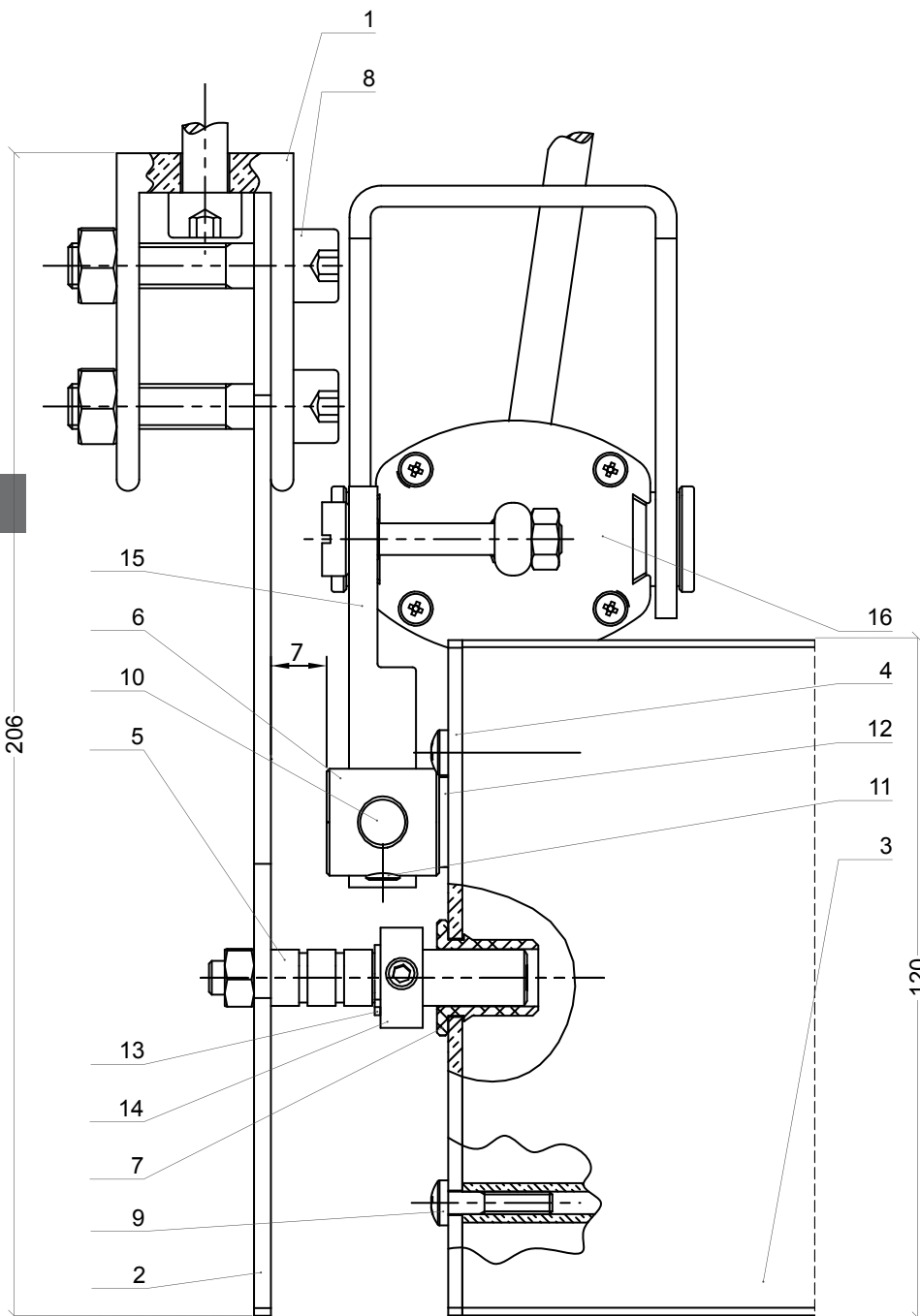

- 1 **U-09** (profil soutien U-09)
- 2 **31 15 00 71** (haut fixation allongé Z-58)
- 3 **Z-58** (lame 120 mm)
- 4 **31 15 01 01** (haut ouvrant)
- 5 **30 15 11 24** (axe pour ouvrant de rotation)
- 6 **31 15 11 28** (axe de connexion lame)
- 7 **30 15 11 31** (Casquette en nylon pour axe)
- 8 **Boulon** DIN 912 M8x40
- 9 **Boulon** ISO 7045 M4x16
- 10 **G-01** (profil 8 mm)
- 11 **Boulon** DIN 913 M6x6
- 12 **Rondelle** en nylon 16x1.6)
- 13 **Frein** TRUARC
- 14 **31 15 11 26** (anneau excentrique d'ajustement)
- 15 **31 15 11 25** (connexion au moteur/commande manuelle)
- 16 **30 15 10 84** (moteur électrique)

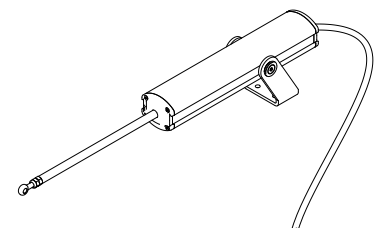

Assemblage de moteur toujours avec le piston pour basse

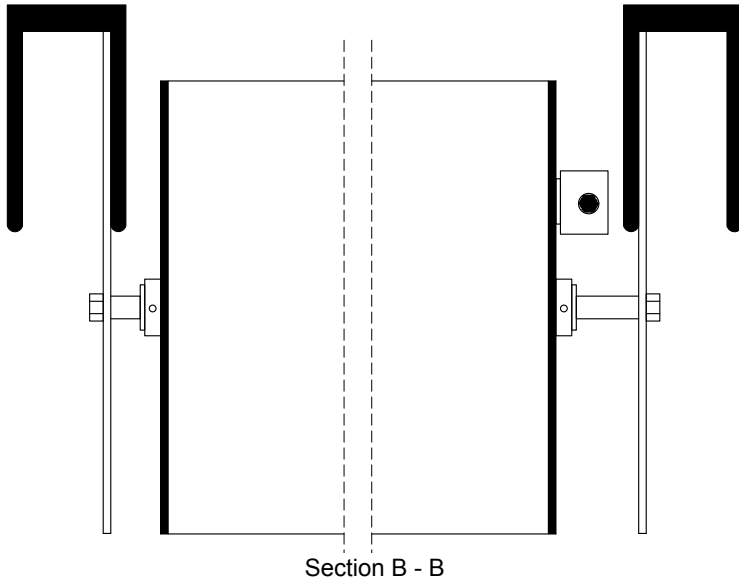

Section B - B

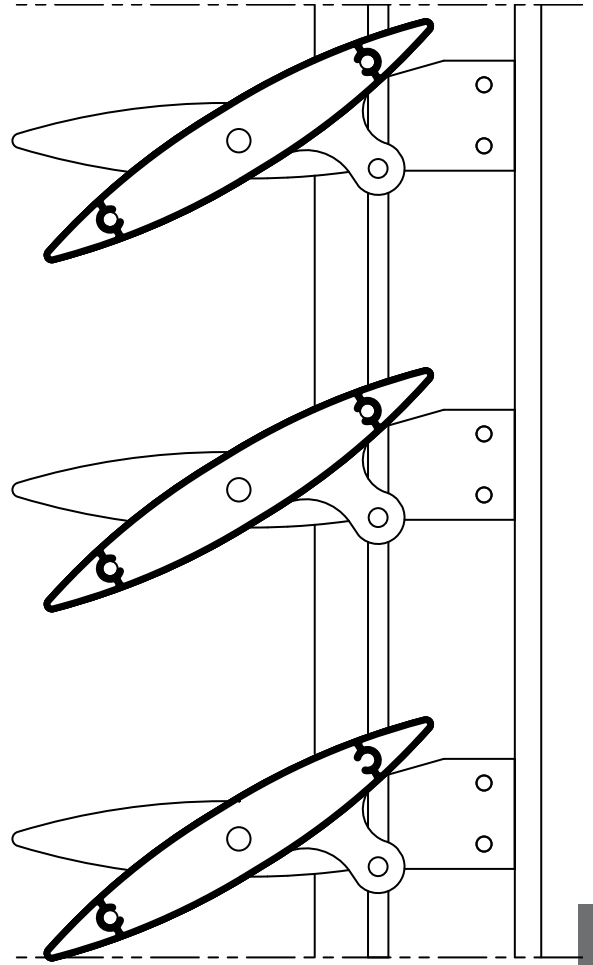
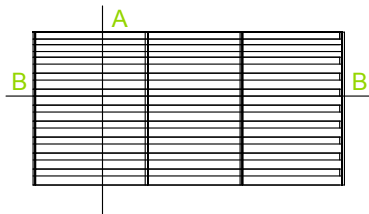

Section A - A

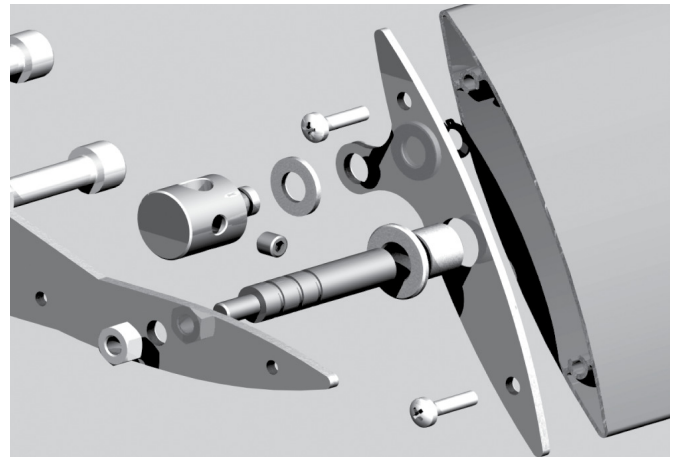
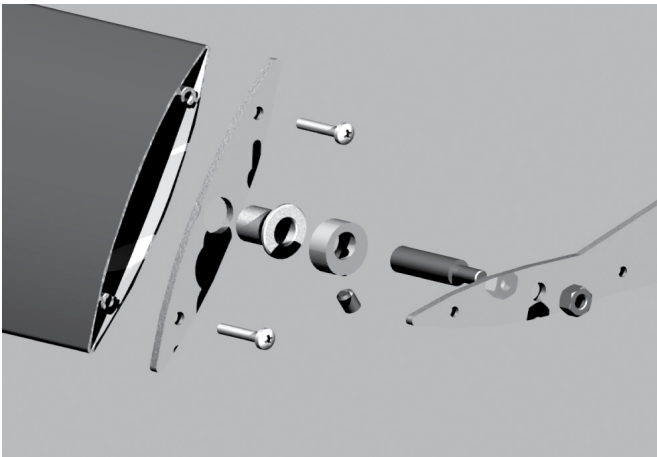

- 1 **U-09** (profil soutien U-09)
- 2 **31 15 00 79** (haut fixation allongé 250 mm)
- 3 **Z-62** (lame 250 mm)
- 4 **31 15 01 12** (haut ouvrant)
- 5 **30 15 12 24** (axe pour ouvrant de rotation)
- 6 **31 15 12 28** (axe de connexion lame)
- 7 **30 15 12 31** (Casquette en nylon pour axe)
- 8 **Boulon DIN 912 M8x40**
- 9 **Boulon ISO 7045 M4x16**
- 10 **G-01** (profil 8 mm)
- 11 **Boulon DIN 913 M6x6**
- 12 **Anilha en nylon 16x1.6**
- 13 **Frein TRUARC**
- 14 **31 15 11 26** (anneau excentrique de ajustement)
- 15 **31 15 11 25** (connexion au moteur/commande manuelle)
- 16 **30 15 10 84** (moteur électrique)

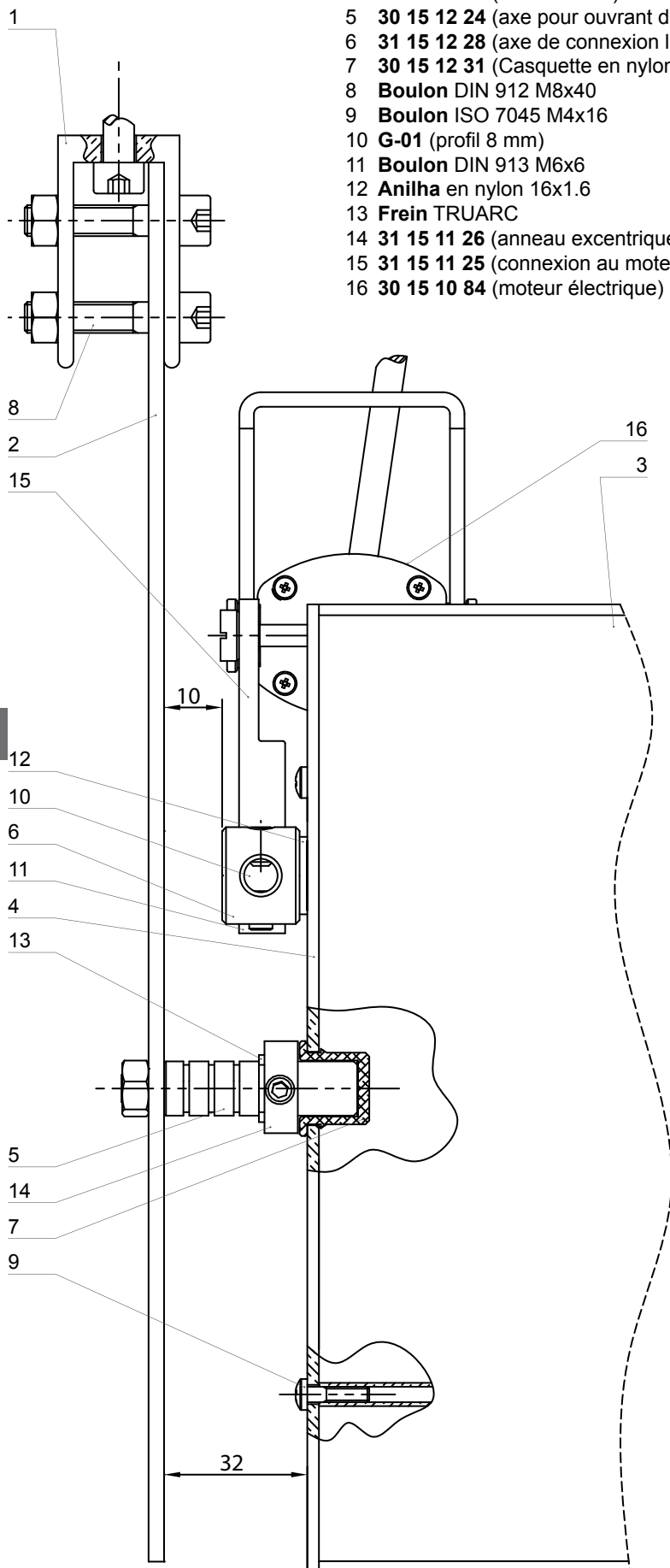

452

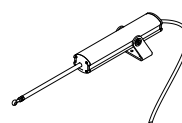

Assemblage de
moteur toujours
avec le piston
pour bas

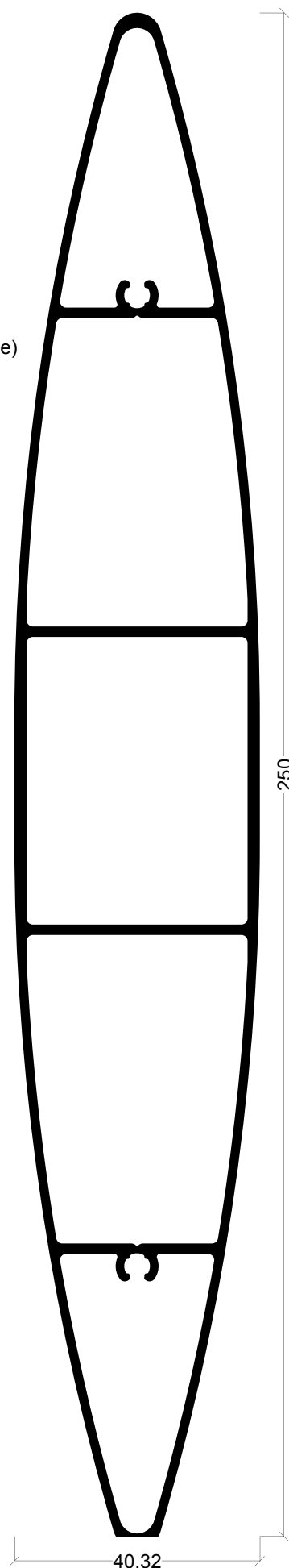

Z-62

