



anicolor

Sistemas de Alumínio



Hortus

Sistema de Portões

Sistema Hortus

Sistema de portões e gradeamento

Características do sistema

Sistema de alumínio para executar portões de batente ou de correr para entrada de habitações, possibilitando a execução de gradeamentos com a mesma aparência.
Produto executado de acordo com a norma europeia de Regulamentação geral EN 13241-1 de desempenho e de segurança.
O sistema Hortus alia os conceitos de qualidade, durabilidade e elegância, possuindo igualmente uma gama de acessórios de fácil aplicação e reduzida manutenção.
Os modelos de portão são compatíveis com os automatismos clássicos para abertura de batente ou de correr.

Perfis de alumínio

Os perfis de alumínio são extrudidos na liga de alumínio 6060 para a arquitetura de acordo com a norma NP EN 12020-02.
Os perfis de alumínio que compõe o sistema Hortus são lacados mediante o selo de qualidade Qualicoat, incluindo a classe Seaside (equivalente Qualmarine), ou anodizados cumprindo os requisitos do selo de qualidade Qualanod.

Portão de batente

Seção dos principais perfis de 50 mm com uma espessura média de 2.5 mm.
Possibilidade de execução de portão de 1 ou 2 folhas de abertura interior ou exterior com opção de sistema anti-entalamento de dedos.
Existem diversas tipologias de enchimento, de 9 mm a 20 mm.
União dos Aros feita através de parafusos especiais de abertura de rosca direta com tratamento anti-corrosão.
A união é reforçada com calços em alumínio.
Pivot superior em alumínio injetado de eixo 20 mm em inox permitindo afinação milimétrica nos 3 eixos.
Pivot inferior em alumínio injetado de eixo 20 mm permitindo regulações laterais.
Conjunto pivot em Cupro-Alumínio de eixo 12 mm com multi-regulação.
Dobradiças em alumínio de 2 ou 3 abas com reforço interior permitindo afinação nos 3 eixos.

Portão de correr

Seção dos principais perfis de 50 mm com uma espessura média de 2.5 mm.
Possibilidade de execução de portão de correr com diversas tipologias de enchimento de 9 mm a 20 mm.
União dos aros feita através de parafusos especiais de abertura de rosca direta e com tratamento anti-corrosão.
A união é reforçada com calços em alumínio.
Calha com suporte de roletos auto-regulável na vertical.
Fechadura com gancho automático.
Rodas de alta resistência e desempenho.
Calha em aço de 3 ou 6 metros para deslizamento das rodas.

Gradeamento

Seção dos principais perfis de 50 mm com uma espessura média de 2.5 mm.
Idêntica tipologia de perfis utilizada na execução do gradeamento.
União de aros feita através de parafusos especiais de abertura de rosca direta e com tratamento anti-corrosão.
Perfis verticais auto-ajustáveis.

Dimensionamento e manobralidade

Dimensões máximas para portão de batente 1 folha*: 1600 mm (L) x 2200 mm (H)
Dimensões máximas para portão de batente 2 folhas*: 5500 mm (L) x 2000 mm (H)
Dimensões máximas para portão de correr*: 6000 mm (L) x 2200 mm (H)
Dimensões máximas entre prumos para gradeamento*: 6500 mm (L) x 2200 mm (H)

* Dimensionamento máximo variável dependendo da tipologia de enchimento e ferragens de abertura.

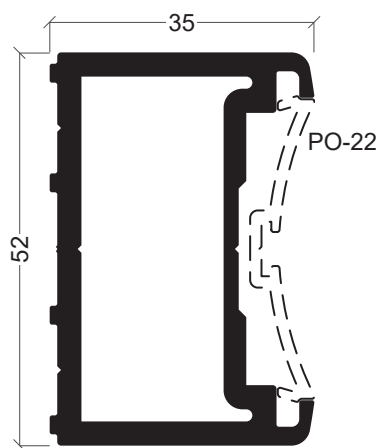

PO-11
Aro fixo

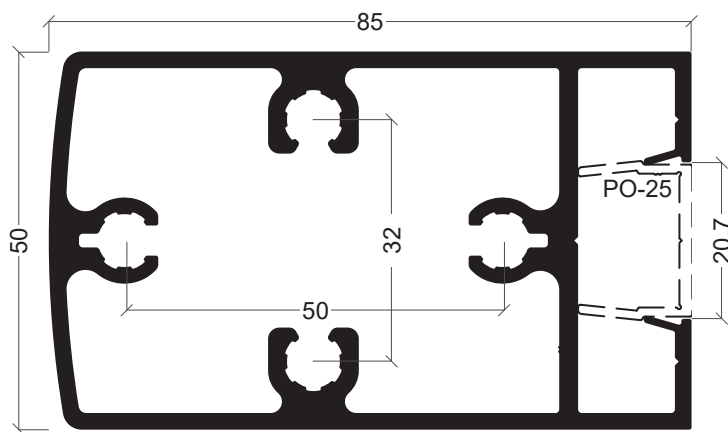

PO-12
Travessa

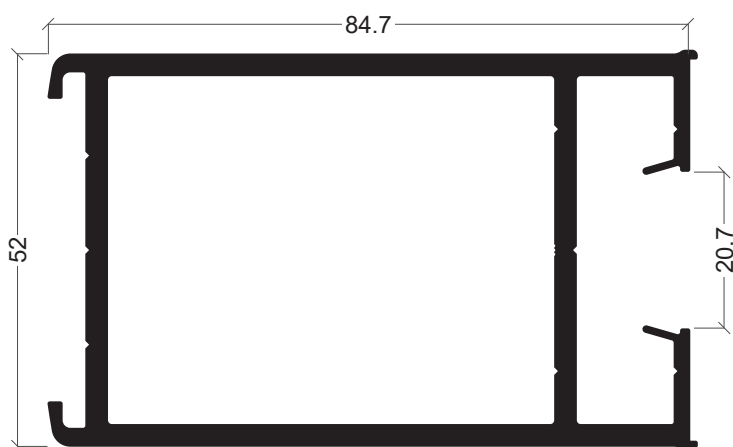

PO-13
Montante

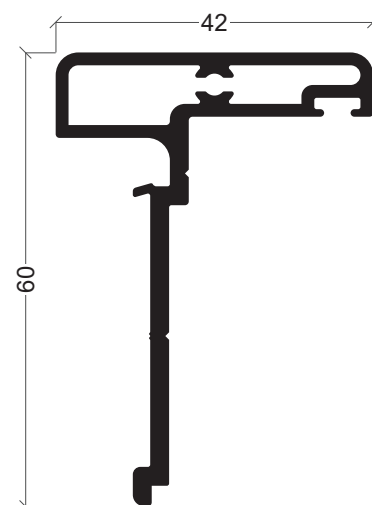

PO-20
Inversor

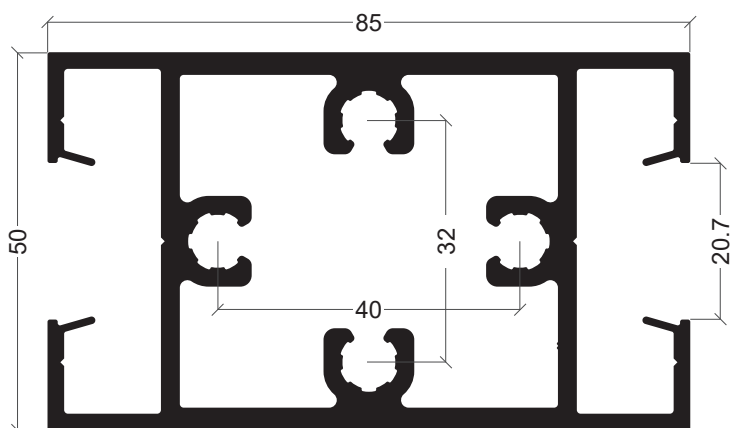

PO-16
Travessa intermédia

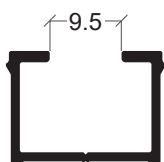

PO-15
Redutor

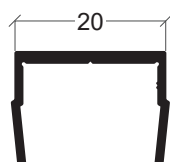

PO-25
Perfil tampa



PO-14
Tampa

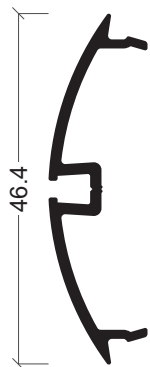

PO-21
Suplemento de batente



PO-22
Suplemento de batente

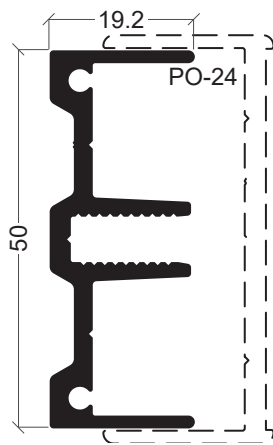

PO-23
Remate gradeamento

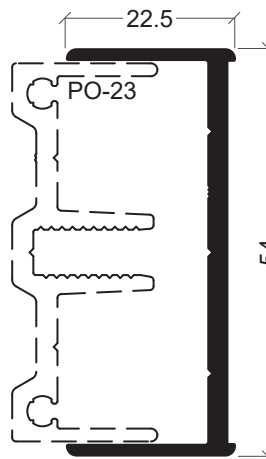

PO-24
Remate gradeamento

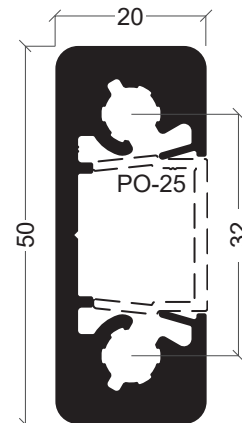

PO-26
Travessa gradeamento

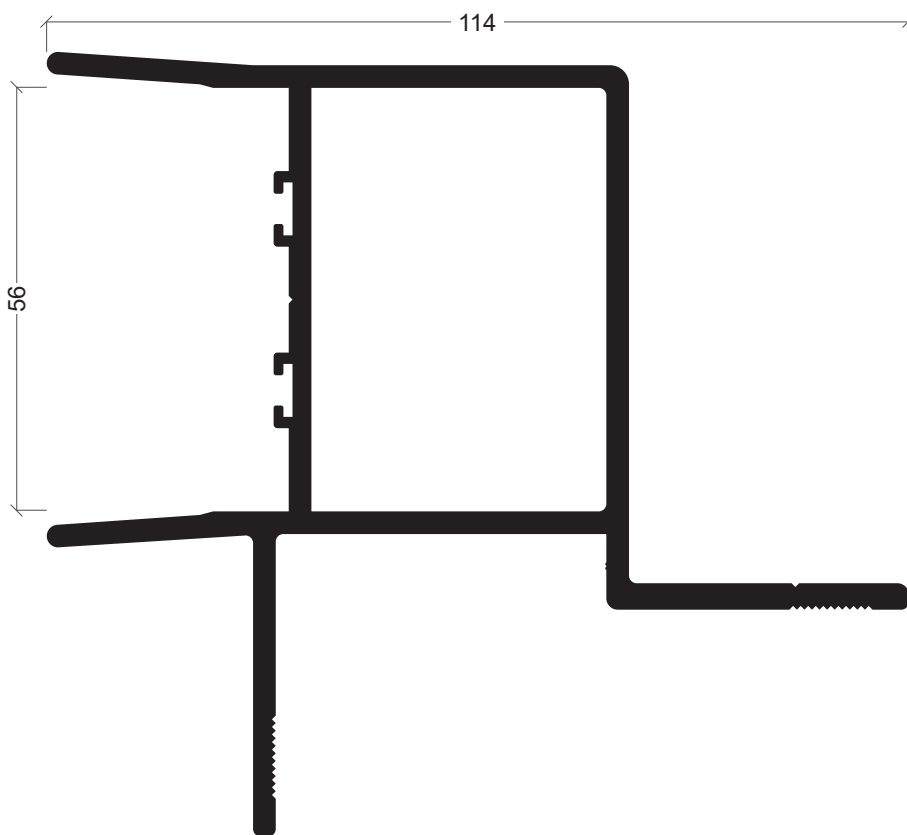

PO-04
Prumo fixo correr

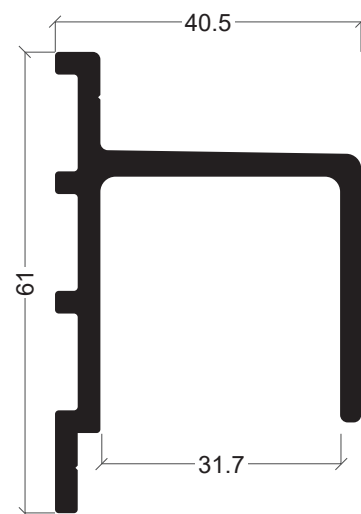

PO-09
Guia correr

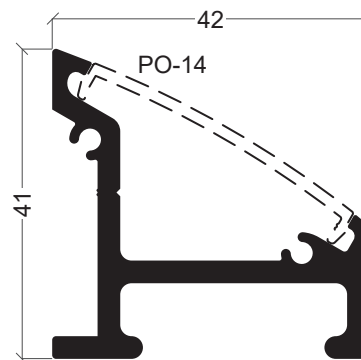

PO-19
Guia correr com tampa

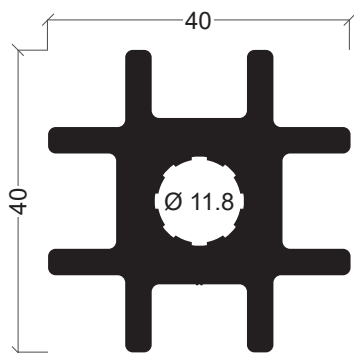

PO-17
Perfil de reforço

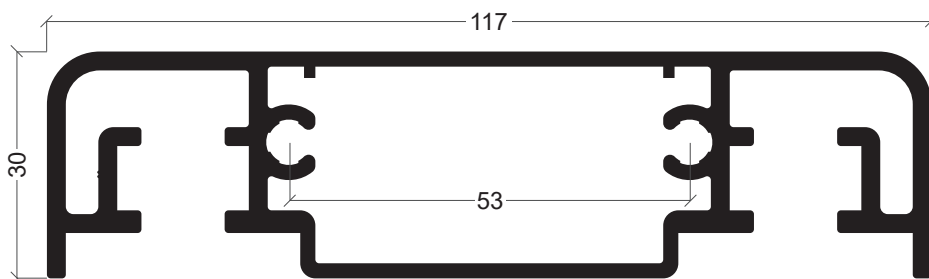

PO-18
Ponte para roletos

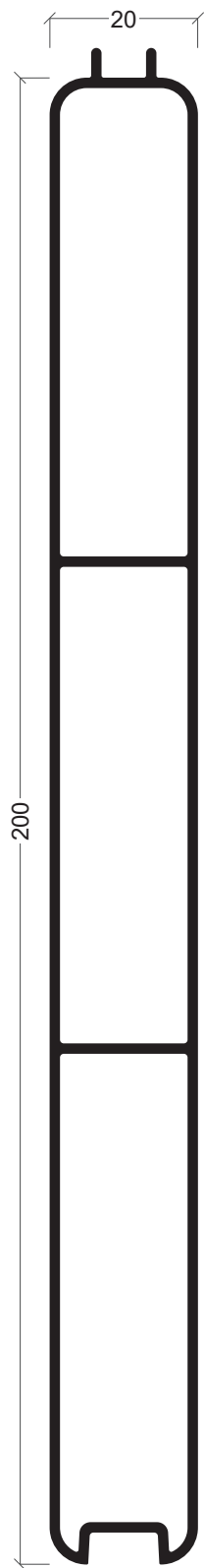

W-12
Lâmina 200 mm

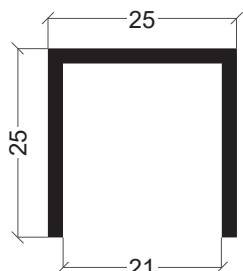

U-11
Perfil de remate

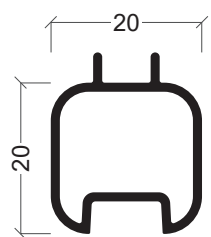

W-16
Lâmina 20 mm

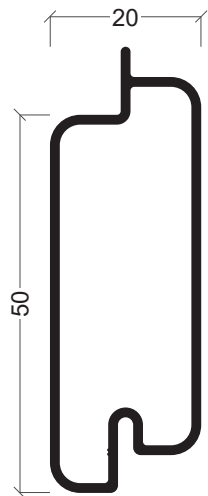

W-26
Lâmina 50 mm



W-23
Lâmina 75.5 mm

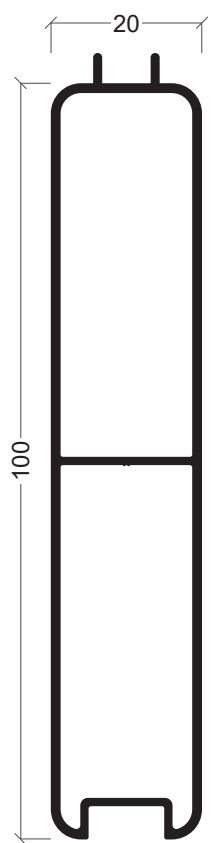

W-27
Lâmina 100 mm

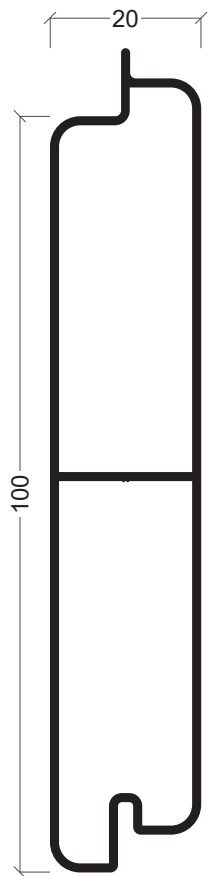

W-25
Lâmina 100 mm

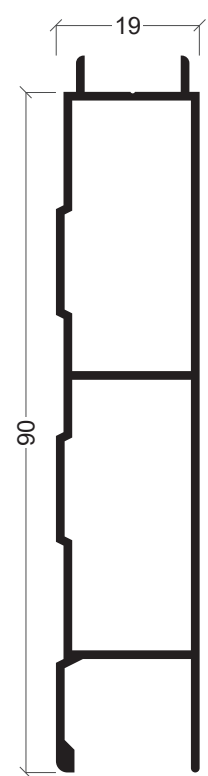

W-21
Lâmina 90 mm

Referência	A	B	Esp.
Q-02	20	-	2
P-11	30	20	1.3
P-04	40	20	1.2
Q-20	60	-	2
Q-09	65	-	1.5
P-21	80	20	1.5
P-14 *	100	20	1.3

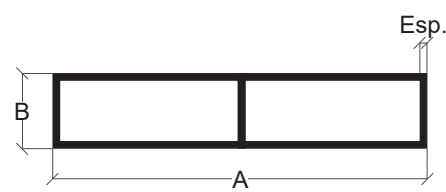
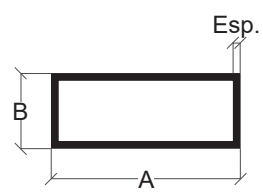
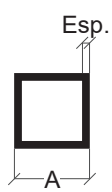

* Parede ao centro

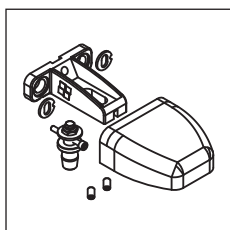

30 01 60 10/11
Pivot superior E20 mm
(branco/preto)

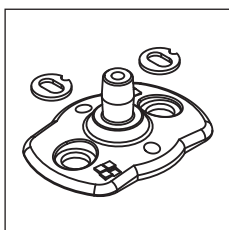

30 01 60 13/14
Pivot inferior E20 mm
(branco/preto)

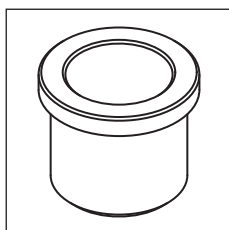

30 01 60 19
Casquilho nylon E20 mm

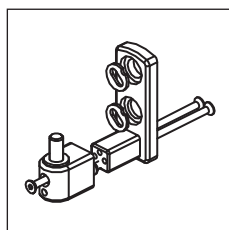

30 01 60 20/21
Conjunto pivot E12 mm
(branco/preto)

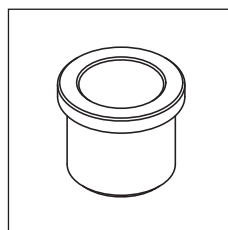

30 01 60 25
Casquilho nylon E12 mm

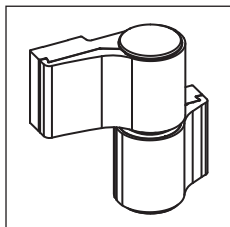

30 01 60 30/31
Dobradiça 2 abas 3D lisa
(branco/preto)

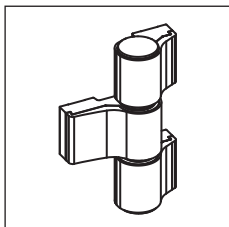

30 01 60 33/34
Dobradiça 3 abas 3D lisa
(branco/preto)

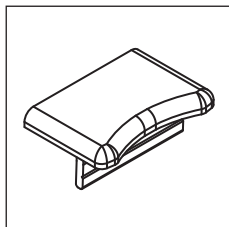

30 01 60 40/41
Topo PO-11 + PO-22
(branco/preto)

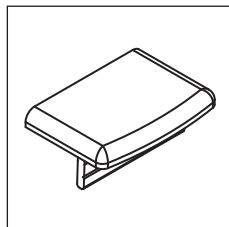

30 01 60 43/44
Topo PO-11 (branco/
preto)

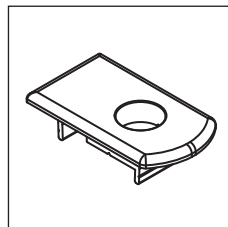

30 01 60 46/47
Topo PO-13 + PO-21
E20 mm (branco/preto)

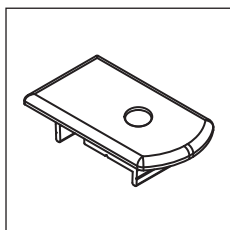

30 01 60 49/50
Topo PO-13 + PO-21
E12 mm (branco/preto)

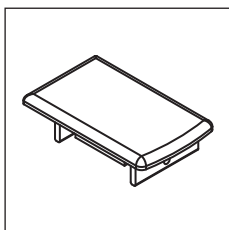

30 01 60 52/53
Topo PO-13 (branco/
preto)

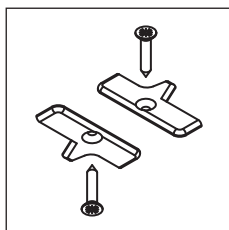

30 01 60 55/56
Jogo topos inversor
PO-20 (branco/preto)

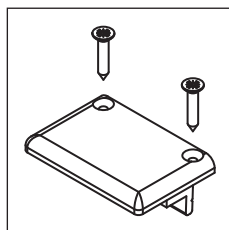

30 01 60 58/59
Topo fixo para gradeamento
(branco/preto)

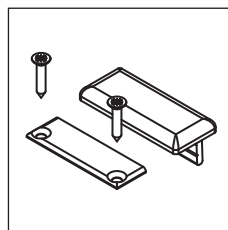

30 01 60 61/62
Jogo topos reg. para
gradeamento (branco/preto)

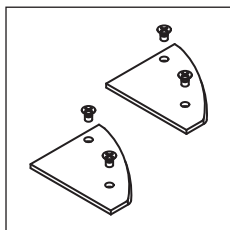

30 01 60 64/65
Jogo topos guia PO-19
(branco/preto)

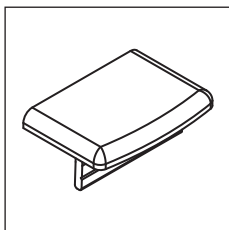

30 01 60 67/68
Topo prumo PO-04
(branco/preto)

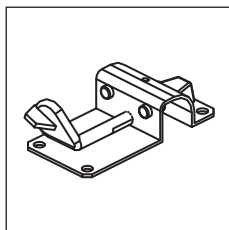

30 01 60 80
Batente central inox
abertura manual

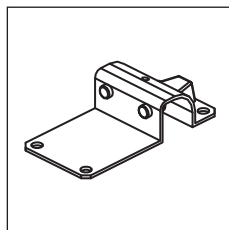

30 01 60 81
Batente central inox
abertura motorizada

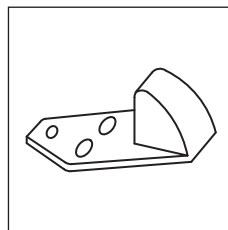

30 01 60 82/83
Batente central abertura
motorizada (branco/preto)

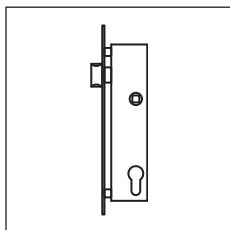

30 01 60 90
Fechadura prumo
batente 40 mm

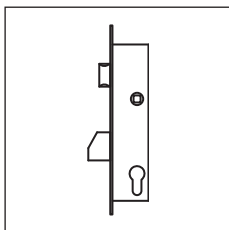

30 01 60 91
Fechadura prumo
batente 35 mm

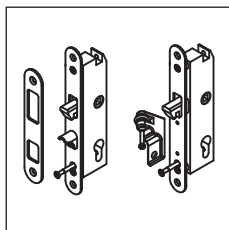

30 01 60 95/96
Fechaduras
semi-automáticas correr

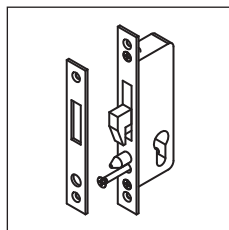

30 01 60 97
Fechadura manual correr

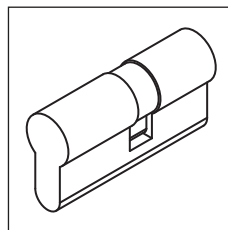

30 01 61 00
Canhão Euro cromado

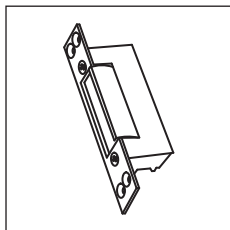

30 01 61 10
Testa elétrica

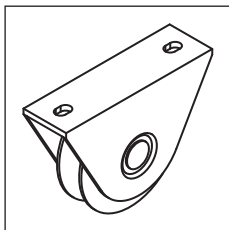

30 01 61 20
Roda com suporte
triangular

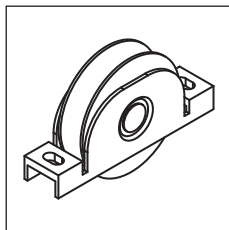

30 01 61 21
Roda com suporte
inferior

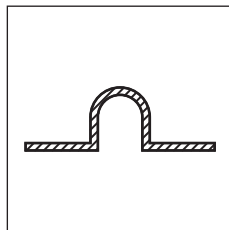

30 01 61 25/26
Calha de aço em U (3
mts / 6 mts)

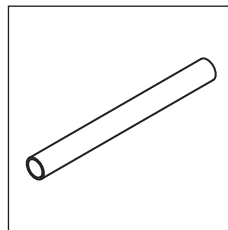

30 01 61 27
União para calha

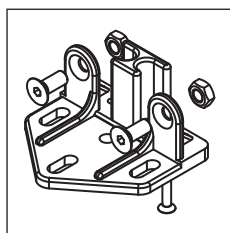

30 01 61 30/31

Fixador para ponte
PO-18 (branco/preto)

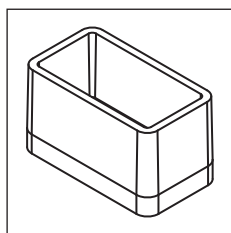

30 01 61 33

Fixador interior para
ponte PO-18

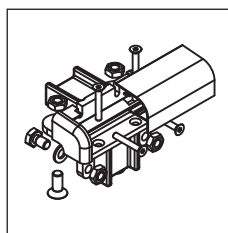

30 01 61 34/35

Ângulo para ponte PO-18
(branco/preto)

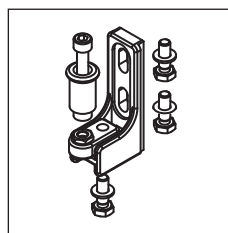

30 01 61 37/38

Suporte regulável para
rolete (branco/preto)

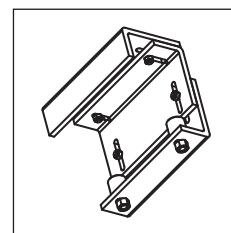

30 01 61 40/41

Ponte com roletos 30
mm (branco/preto)

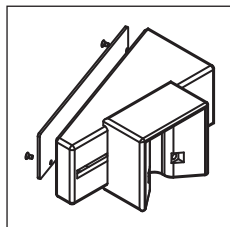

30 01 61 50/51

Conjunto de fecho correr
(branco/preto)

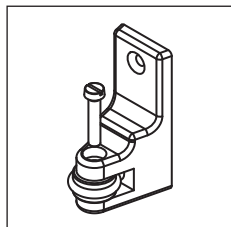

30 01 61 53/54

Engate para fecho correr
(branco/preto)

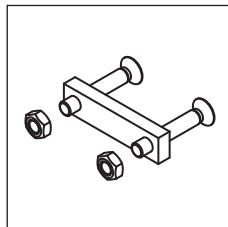

30 01 61 56

Gache fecho correr

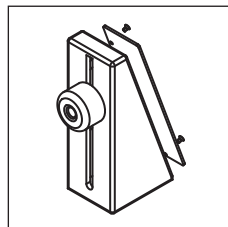

30 01 61 57/58

Batente correr (branco/
preto)

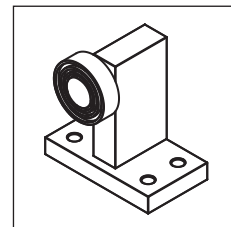

30 01 61 60/61

Batente correr alumínio
(branco/preto)

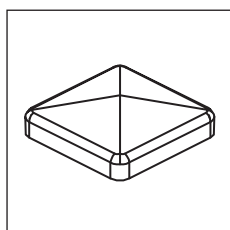

30 01 61 70/71

Topo piramidal 60x60
(branco/preto)

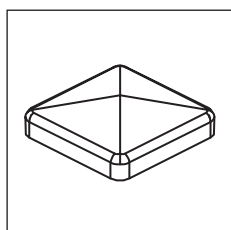

30 01 61 73/74

Topo piramidal 65x65
(branco/preto)

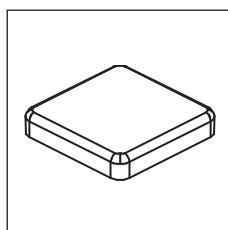

30 01 61 76/77

Topo liso 60x60 (branco/
preto)

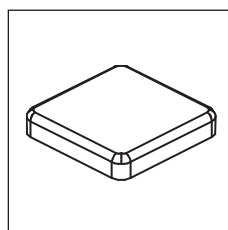

30 01 61 79/80

Topo liso 65x65 (branco/
preto)

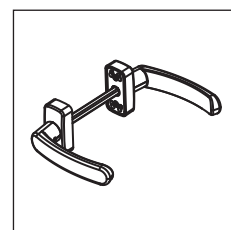

30 92 22 82/83

Puxador duplo (branco/
preto)

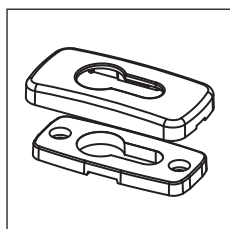

30 92 22 85/86

Escudo para canhão
(branco/preto)

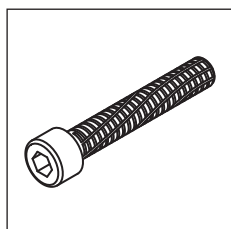

31 01 60 00

Parafuso M8x50
dacromet

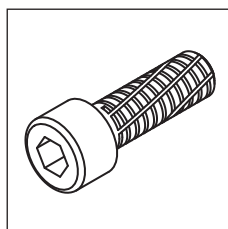

31 01 60 01

Parafuso M8x25
dacromet

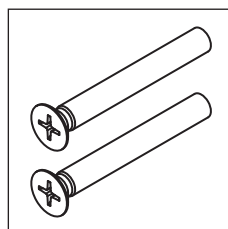

31 01 60 02

Jogo parafusos M5x45
A2

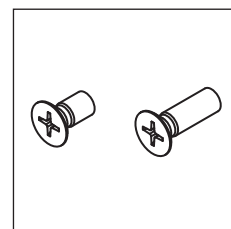

31 01 60 03

Jogo parafusos M5 A2

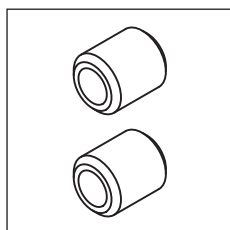

31 01 60 04

Jogo separador 714

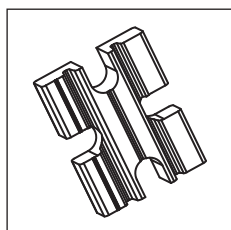

31 01 60 09

Calço de alumínio de
aperto

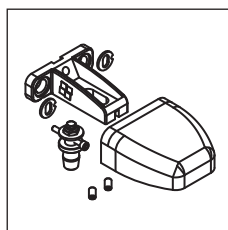

31 01 60 12 *

Pivot superior E20
(bruto)

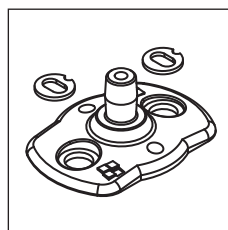

31 01 60 15 *

Pivot inferior E20 (bruto)

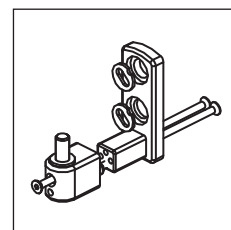

31 01 60 22 *

Conjunto pivot E12
(bruto)

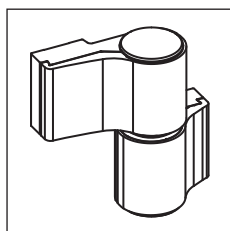

31 01 60 32

Dobradiça 2 abas 3D lisa
(bruto)

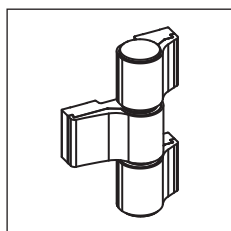

31 01 60 35

Dobradiça 3 abas 3D lisa
(bruto)

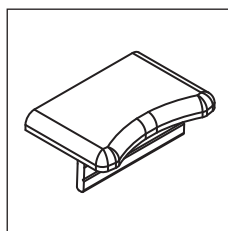

31 01 60 42

Topo PO-11 + PO-22
(bruto)

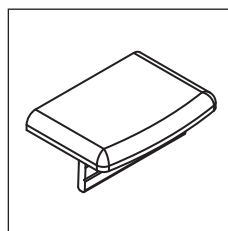

31 01 60 45

Topo PO-11 (bruto)

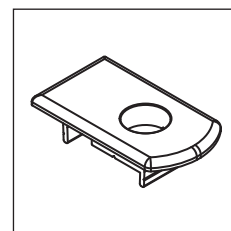

31 01 60 48

Topo PO-13 + PO-21
E20 (bruto)

* Só para lacar

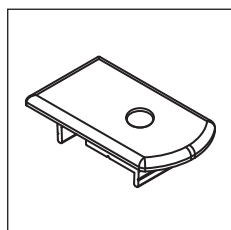

31 01 60 51

Topo PO-13 + PO-21
E12 (bruto)

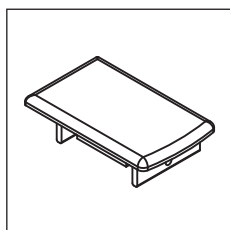

31 01 60 54

Topo PO-13 (bruto)

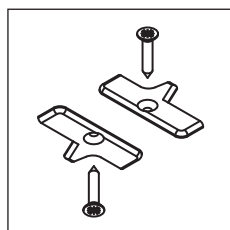

31 01 60 57

Jogo topos inversor
PO-20 (bruto)

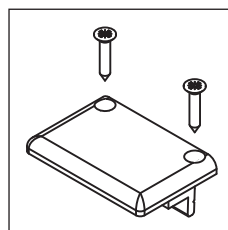

31 01 60 60

Topo fixo para
gradeamento (bruto)

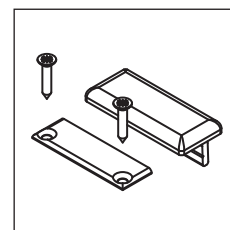

31 01 60 63

Jogo topos reg. para
gradeamento (bruto)

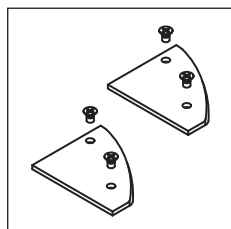

31 01 60 66

Jogo topos guia PO-19
(bruto)

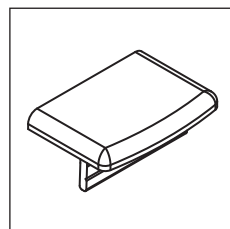

31 01 60 70

Topo prumo PO-04
(bruto)

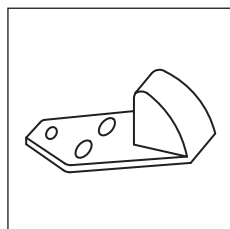

31 01 60 84 *

Batente central abertura
motorizada (bruto)

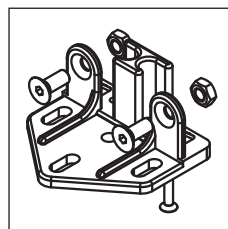

31 01 61 32 *

Fixador para ponte
PO-18 (bruto)

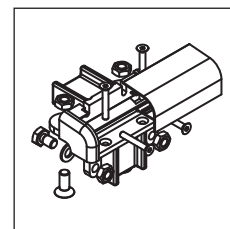

31 01 61 36 *

Ângulo para ponte PO-18
(bruto)

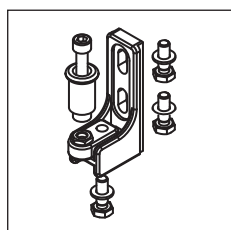

31 01 61 39 *

Suporte regulável para
rolete (bruto)

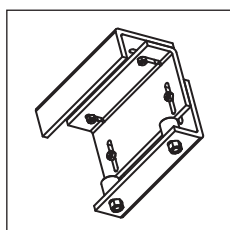

31 01 61 42

Ponte com roletos 30
mm (bruto)

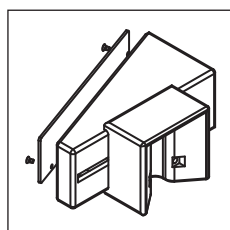

31 01 61 52 *

Conjunto de fecho correr
(bruto)

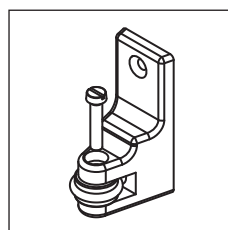

31 01 61 55 *

Engate para fecho correr
(bruto)

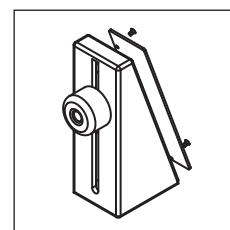

31 01 61 59 *

Batente correr (bruto)

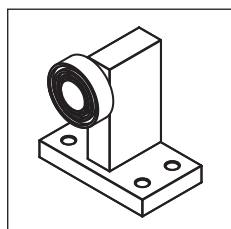

31 01 61 62

Batente correr alumínio
(bruto)

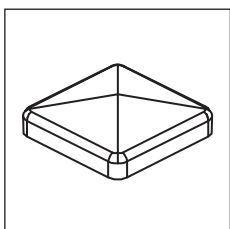

31 01 61 72 *

Topo piramidal 60x60
(bruto)

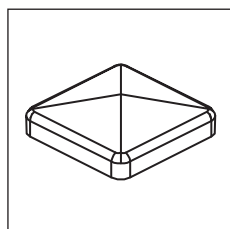

31 01 61 75 *

Topo piramidal 65x65
(bruto)

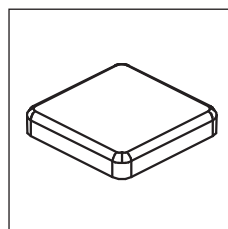

31 01 61 78 *

Topo liso 60x60 (bruto)

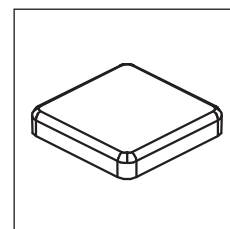

31 01 61 81 *

Topo liso 65x65 (bruto)

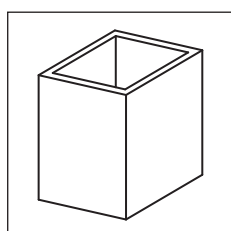

31 01 61 82 *

Fixador pavimento 60x60
(bruto)

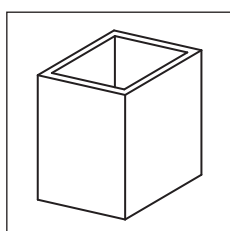

31 01 61 85 *

Fixador pavimento 65x65
(bruto)

Referência	Desenho	Descrição
30 01 62 00		Junta para inversor (preto)
30 60 00 14		Perfil pelúcia 18 mm (3 mts preto)
30 60 00 20		Perfil pelúcia 29 mm (3 mts preto)
30 80 10 22		Junta cunha recartilhada 7 mm
30 93 00 65		Junta cunha 5 mm (preto)
30 93 00 66		Junta cunha 4 mm (preto)
30 93 00 67		Junta cunha 2 mm (preto)
30 93 00 68		Junta cunha 6/7 mm (preto)
30 93 00 69		Junta cunha 8/9 mm (preto)
30 94 01 48		Junta de correr
30 95 00 10		Pelúcia Stop-Fin

* Só para lacar

Lp = Largura espaço para o portão
Lf = Largura da folha
LTpc = Largura do portão de correr
Lg = Largura do gradeamento

Hp = Altura do portão
Hpilar = Altura do pilar de sustentação
HTp = Altura do portão incluído pivot (batente) ou ponte (correr)

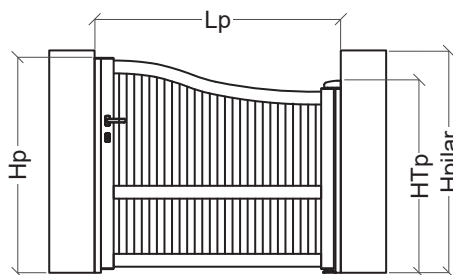
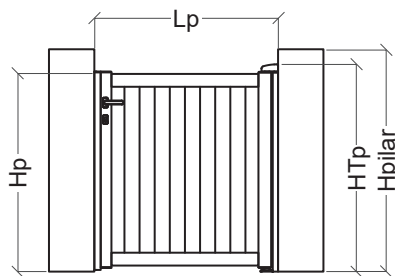

Portão de 1 Folha

Dimensões mínimas:

Lp mini: 600 mm

Hp mini: 600 mm

Hpilar > 100 mm (mínimo) que HTP ou Hpilar > 100 mm (mínimo) que Hp

Dimensões máximas*:

Lp maxi: 1600 mm

Hp maxi: 2200 mm

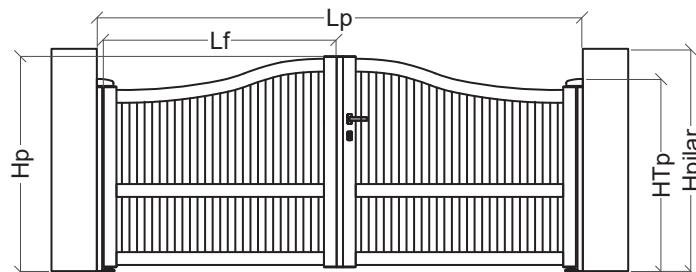
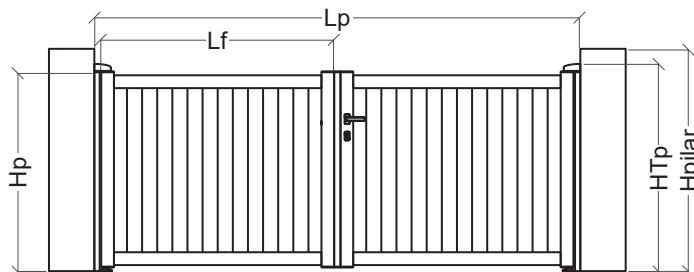

Portão de 2 Folhas

Dimensões mínimas:

Lp mini: 1200 mm

Hp mini: 600 mm

Hpilar > 100 mm (mínimo) que HTP ou Hpilar > 100 mm (mínimo) que Hp

Dimensões máximas*:

Lp maxi: 5500 mm - Lf maxi = 2716 mm

Hp maxi: 2000 mm

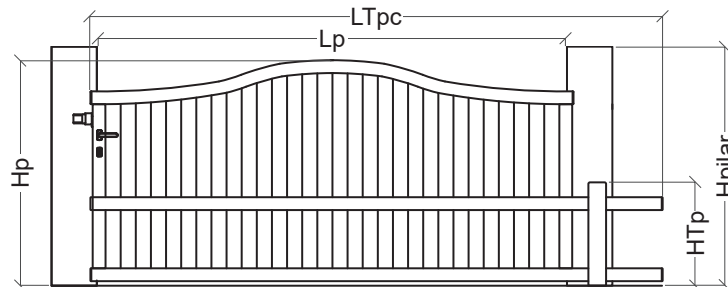
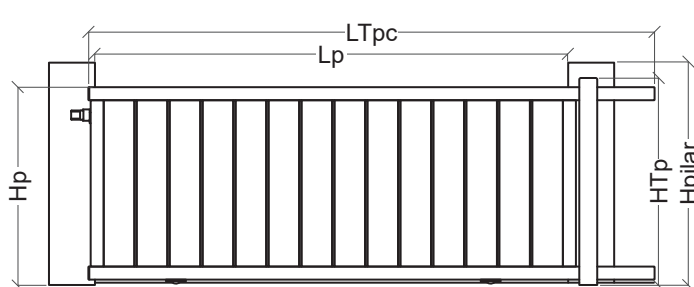

Portão de Correr

Dimensões mínimas:

Lp mini: 600 mm

Hp mini: 600 mm

Hpilar > 100 mm (mínimo) que HTP ou Hpilar > 100 mm (mínimo) que Hp

Peso máximo: 300 kg

Dimensões máximas*:

Lp maxi: 4000 mm (com 2 rodas) ou 4001 mm - 6000 mm (com 4 rodas)

Hp maxi: 2200 mm

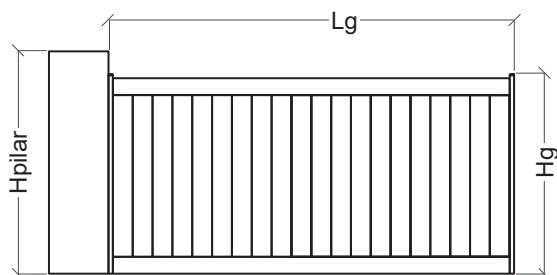

Gradeamento

Dimensões mínimas:

Lg mini: 264 mm

Hg mini: 250 mm

Dimensões máximas*:

Lg maxi: 6500 mm







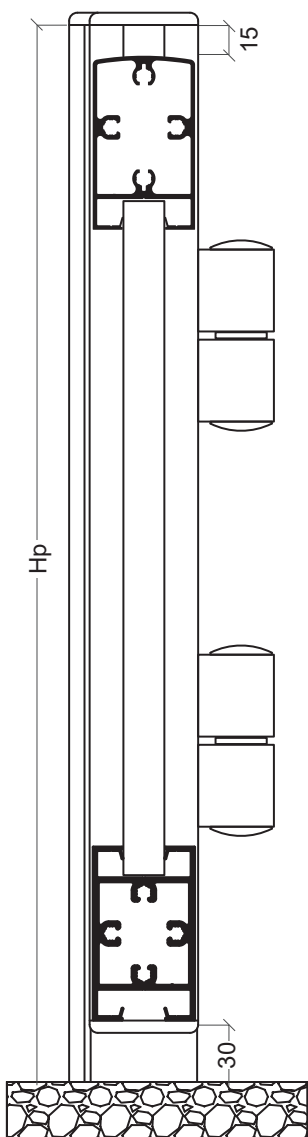
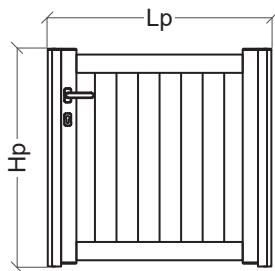









Hg maxi: 2200 mm

* Sujeito a confirmação em função da tipologia

Portão de 1 Folha Abrir com Dobradiças

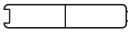

Perfis

Desenho	Ref	Descrição	Corte	Quant	Medida
	PO-11	Aro fixo		2	Hp
	PO-12	Travessa		1	Lp-264 mm
	PO-13	Montante		2	Hp-30 mm
	PO-14	Tampa		2	Hp-30 mm
	PO-16	Travessa inferior		1	Lp-264 mm
	PO-20	Inversor		2	Hp
	PO-25	Perfil tampa		2	20 mm
	W-27	Lâmina		várias	Hp-186 mm

Acessórios e Juntas



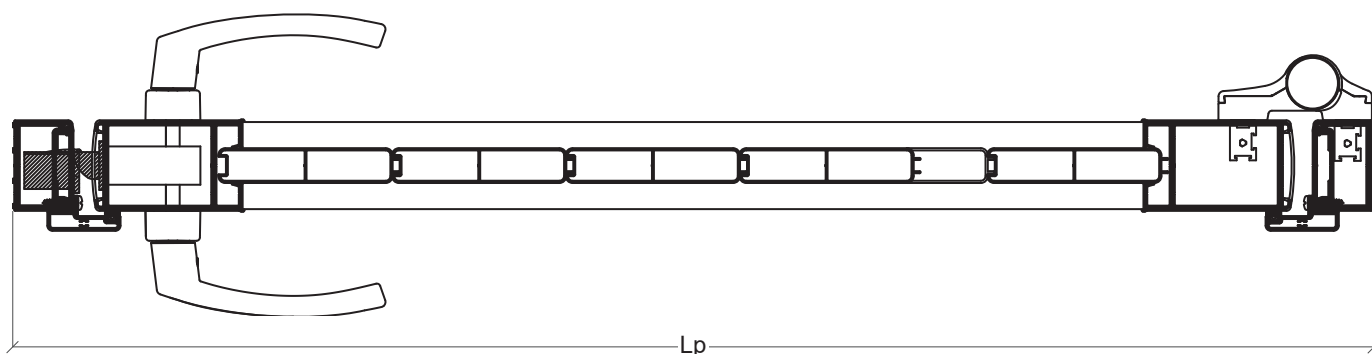



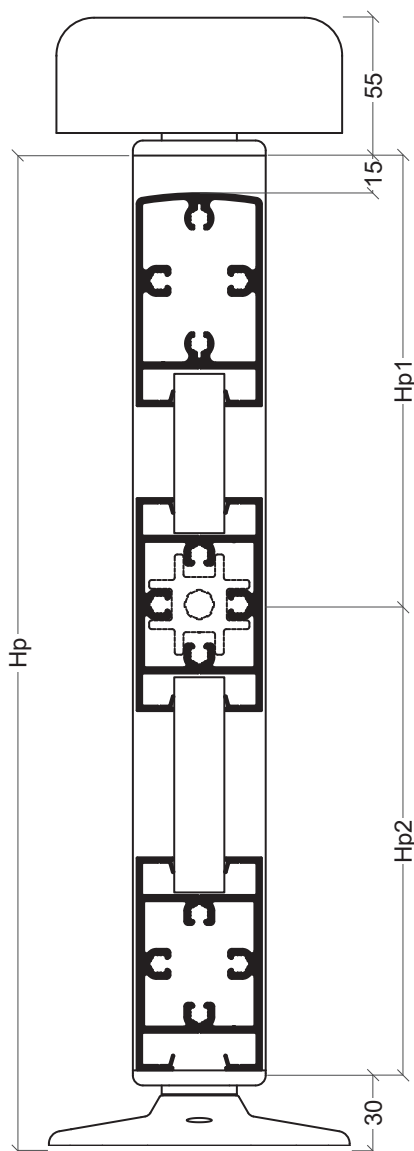
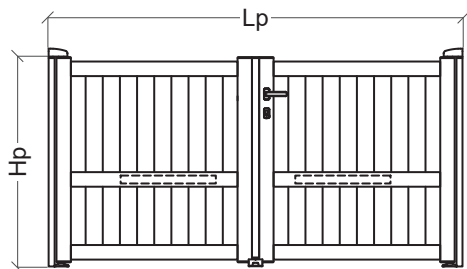















Referência	Descrição	Quantidade
30 01 60 30	Dobradiça 2 abas 3D lisa (Hp < 1500 mm)	2
30 01 60 43	Topo PO-11	2
30 01 60 52	Topo PO-13	4
30 01 60 55	Jogo topo inversor	2
30 01 60 90	Fechadura prumo	1
30 01 61 00	Canhão cromado	1
30 01 61 10	Testa elétrica	1
30 01 62 00	Junta inversor	2Hp
30 92 22 82	Puxador duplo	1
30 92 22 85	Escudo para canhão	2
31 01 60 00	Parafuso M8x50 dacromet	16
31 01 60 09	Calço de aperto	4



Portão de 2 Folhas Abrir com Conjunto Pivot E20

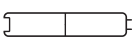

Perfis

Desenho	Ref	Descrição	Corte	Quant	Medida
	PO-11	Aro fixo		2	Hp
	PO-12	Travessa		2	Lp/2-220 mm
	PO-13	Montante		4	Hp-30 mm
	PO-14	Tampa		1	Hp-30 mm
	PO-16	Travessa intermédia		4	Lp/2-220 mm
	PO-20	Inversor		1	Hp-30 mm entalhe no extremo inferior
	PO-21	Suplemento		2	Hp-30 mm
	PO-22	Suplemento		2	Hp
	PO-25	Perfil tampa		4	20 mm
	W-27	Lâmina		várias	Hp1-114 mm
				várias	Hp2-129 mm
	PO-17	Perfil de reforço (para automatismo)		2	800 mm

Acessórios e Juntas



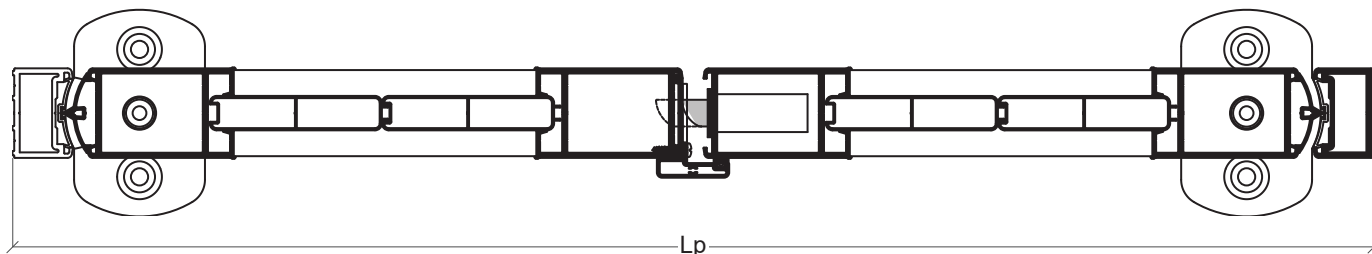



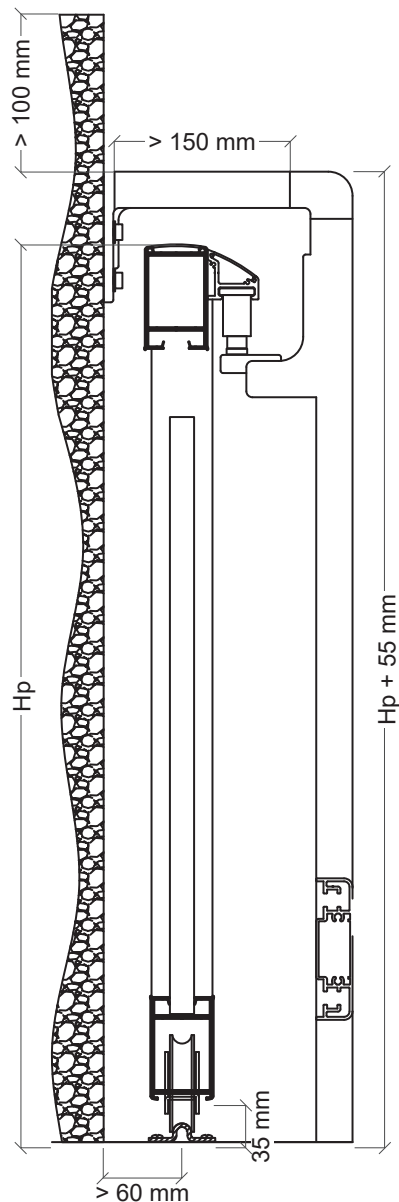
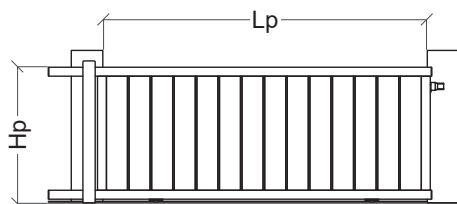













Referência	Descrição	Quantidade	
		Manual	Motorizado
30 01 60 10	Pivot superior	2	
30 01 60 13	Pivot inferior	2	
30 01 60 19	Casquilho nylon E20	4	
30 01 60 40	Topo PO-11 + PO-22	2	
30 01 60 46	Topo PO-13 + PO-21 E20	4	
30 01 60 52	Topo PO-13	4	
30 01 60 55	Jogo topos inversor PO-20	1	
30 01 60 80	Batente central (manual)	1	-
30 01 60 81	Batente central (motorizado)	-	1
30 01 60 90	Fechadura prumo	1	-
30 01 61 00	Canhão cromado	1	-
30 01 62 00	Junta para inversor	Hp	
30 92 22 82	Puxador duplo	1	-
30 92 22 85	Escudo para canhão	2	-
30 95 00 10	Pelúcia Stop-Fin	2Hp	
31 01 60 00	Parafuso M8x50 dacromet	48	
31 01 60 09	Calço de aperto	12	



Portão de Correr com Roletos Especiais

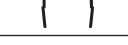

Perfis

Desenho	Ref	Descrição	Corte	Quant	Medida	
					Manual	Motorizado
	PO-13	Perfil para travessas		2	Lp+200 mm	Lp+500 mm
	PO-14	Tampa superior		2	Lp+200 mm	Lp+500 mm
	PO-16	Perfil para prumos		2	Hp-206 mm	
	PO-18	Ponte para roletos especiais		1	Hp+16 mm	
	PO-18	Ponte para roletos especiais		1	>150 mm	
	PO-19	Guia para roletos especiais		1	Lp+200 mm	Lp+500 mm
	PO-25	Perfil tampa		2	Hp-206 mm	
	PO-25	Perfil tampa		2	160 mm	400 mm
	W-12	Lâmina de 200 mm		várias	Hp-178 mm	
	W-16	Lâmina de 20 mm		várias	Hp-178 mm	

Acessórios e Juntas



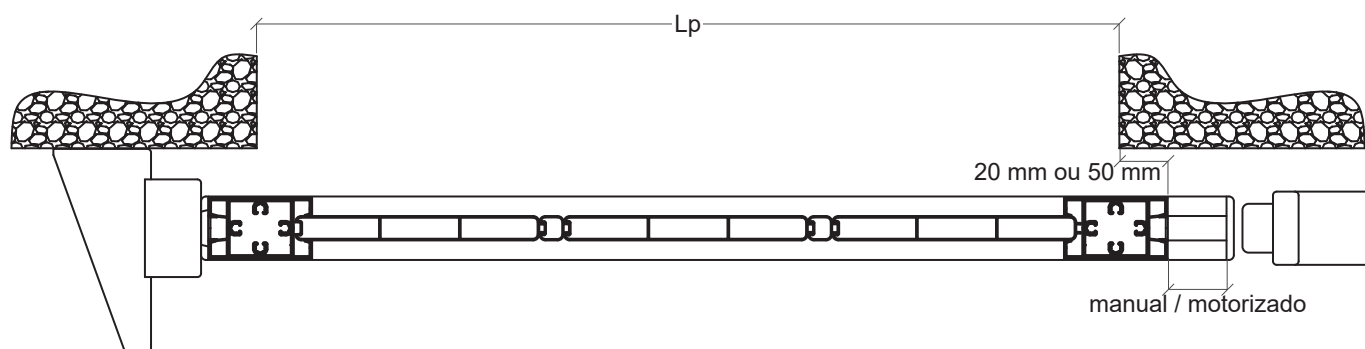



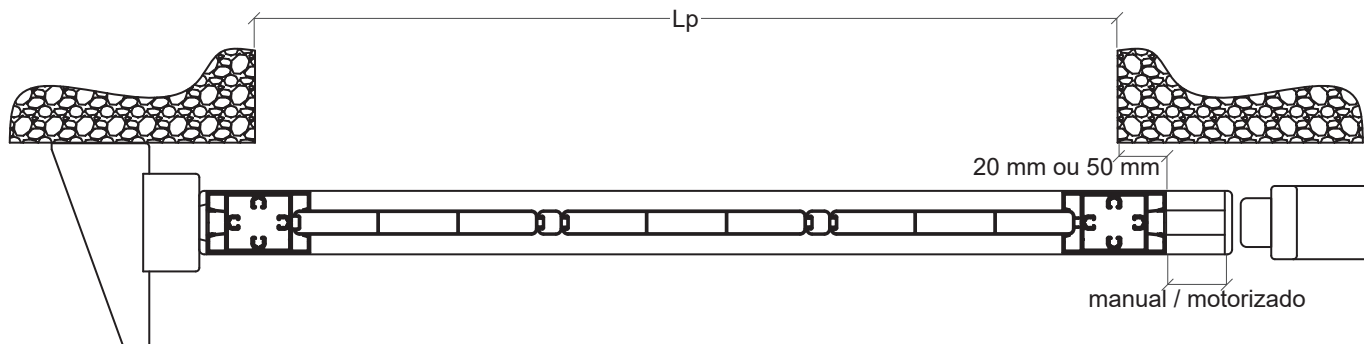
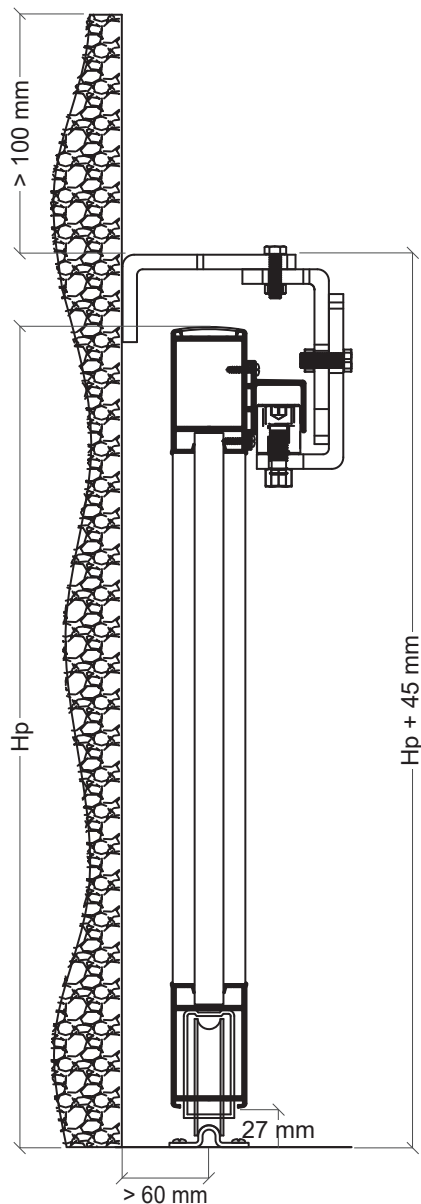
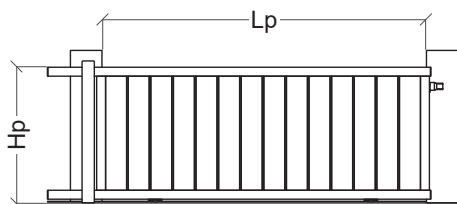







Referência	Descrição	Quantidade	
		Manual	Motorizado
30 01 60 52	Topo PO-13	4	
30 01 60 64	Jogo topos PO-19	1	
30 01 60 96	Fechadura semi-automática	1	-
30 01 61 00	Canhão	1	-
30 01 61 21	Roda com suporte inferior	2 (Lp>4000 mm = 4)	
30 01 61 26	Calha de aço em U (6 mts)	Lp x 2 + 500 mm	
30 01 61 27	União para calha	1	
30 01 61 30	Fixador para PO-18	1	
30 01 61 33	Fixador interior para PO-18	1	
30 01 61 34	Ângulo para PO-18	1	
30 01 61 37	Suporte regulável para roletos	2	
30 01 61 50	Conjunto fecho correr	1	
30 01 61 53	Engate para fecho correr	-	1
30 01 61 56	Gache fecho correr	1	-
30 01 61 57	Batente correr	1	
30 92 22 82	Puxador duplo	1	-
30 92 22 85	Escudo para canhão	2	-
31 01 60 00	Parafuso M8x50	16	
31 01 60 02	Jogo parafuso M5x45	1	-
31 01 60 03	Jogo parafuso M5	1	-
31 01 60 04	Jogo separador 714	1	-
31 01 60 09	Calço de alumínio	4	



Portão de Correr com Roletos de 30 mm



Perfis

Desenho	Ref	Descrição	Corte	Quant	Medida	
					Manual	Motorizado
	PO-13	Perfil para travessas		2	Lp+200 mm	Lp+500 mm
	PO-14	Tampa superior		1	Lp+200 mm	Lp+500 mm
	PO-16	Perfil para prumos		2	Hp-198 mm	
	PO-09	Guia para roletos 30 mm		1	Lp+200 mm	Lp+500 mm
	PO-25	Perfil tampa		2	Hp-198 mm	
	PO-25	Perfil tampa		2	160 mm	400 mm
	W-12	Lâmina de 200 mm		várias	Hp-170 mm	
	W-16	Lâmina de 20 mm		várias	Hp-170 mm	

Acessórios e Juntas

Referência	Descrição	Quantidade	
		Manual	Motorizado
30 01 60 52	Topo PO-13	4	
30 01 60 96	Fechadura semi-automática	1	-
30 01 61 00	Canhão	1	-
30 01 61 20	Roda com suporte triangular	2 (Lp>4000 mm = 4)	
30 01 61 26	Calha de aço um U (6 mts)	Lp x 2 + 500 mm	
30 01 61 27	União para calha	1	
30 01 61 40	Ponte com roletos 30 mm	1	
30 01 61 50	Conjunto fecho correr	1	
30 01 61 53	Engate para fecho correr	-	1
30 01 61 56	Gache fecho correr	1	-
30 01 61 60	Batente correr alumínio	1	
30 92 22 82	Puxador duplo	1	-
30 92 22 85	Escudo para canhão	2	-
31 01 60 00	Parafuso M8x50	16	
31 01 60 02	Jogo parafuso M5x45	1	-
31 01 60 03	Jogo parafuso M5	1	-
31 01 60 04	Jogo separador 714	1	-
31 01 60 09	Calço de alumínio	4	

Gradeamento

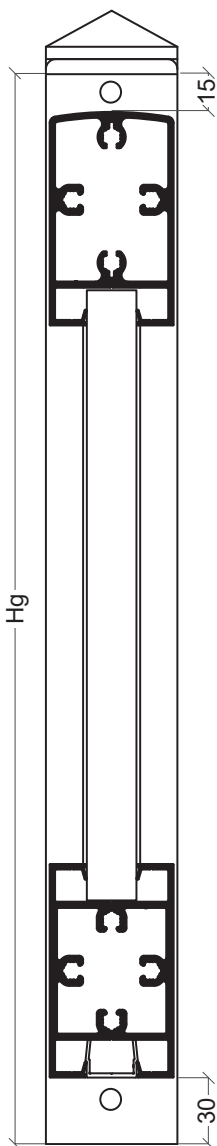
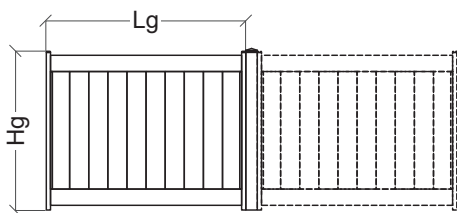

Perfis

Desenho	Ref	Descrição	Corte	Quant	Medida
	PO-12	Travessa		1	Lg-56 mm
	PO-16	Travessa inferior		1	Lg-56 mm
	PO-23	Remate gradeamento		2	Hg-2 mm
	PO-24	Remate gradeamento		2	Hg
	PO-25	Tampa de remate		1	Lg-56 mm
	W-27	Lâmina		várias	Hg-186 mm
	Q-20	Prumo		1	Hg+6 mm
	U-11	Remate lateral		2	Hg-215 mm

Acessórios e Juntas

Referência	Descrição	Quantidade
30 01 60 61	Jogo topos reguláveis	2
31 01 61 82	Fixador pavimento	1
30 01 61 70	Topo piramidal 60x60	1
31 01 60 01	Parafuso M8x25 dacromet	8

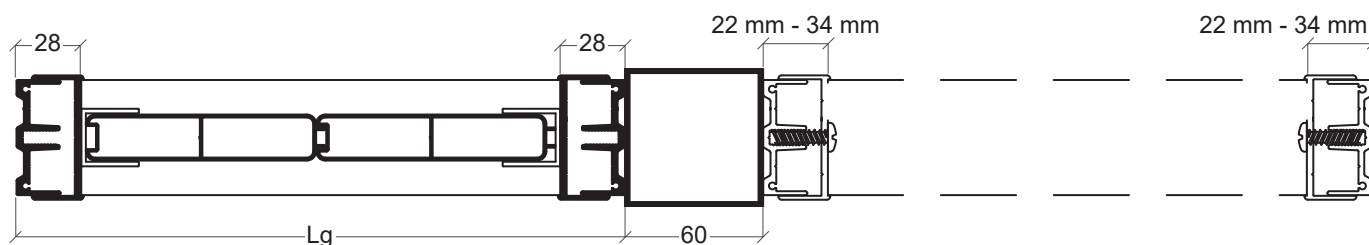

Exemplos de Tipologias possíveis

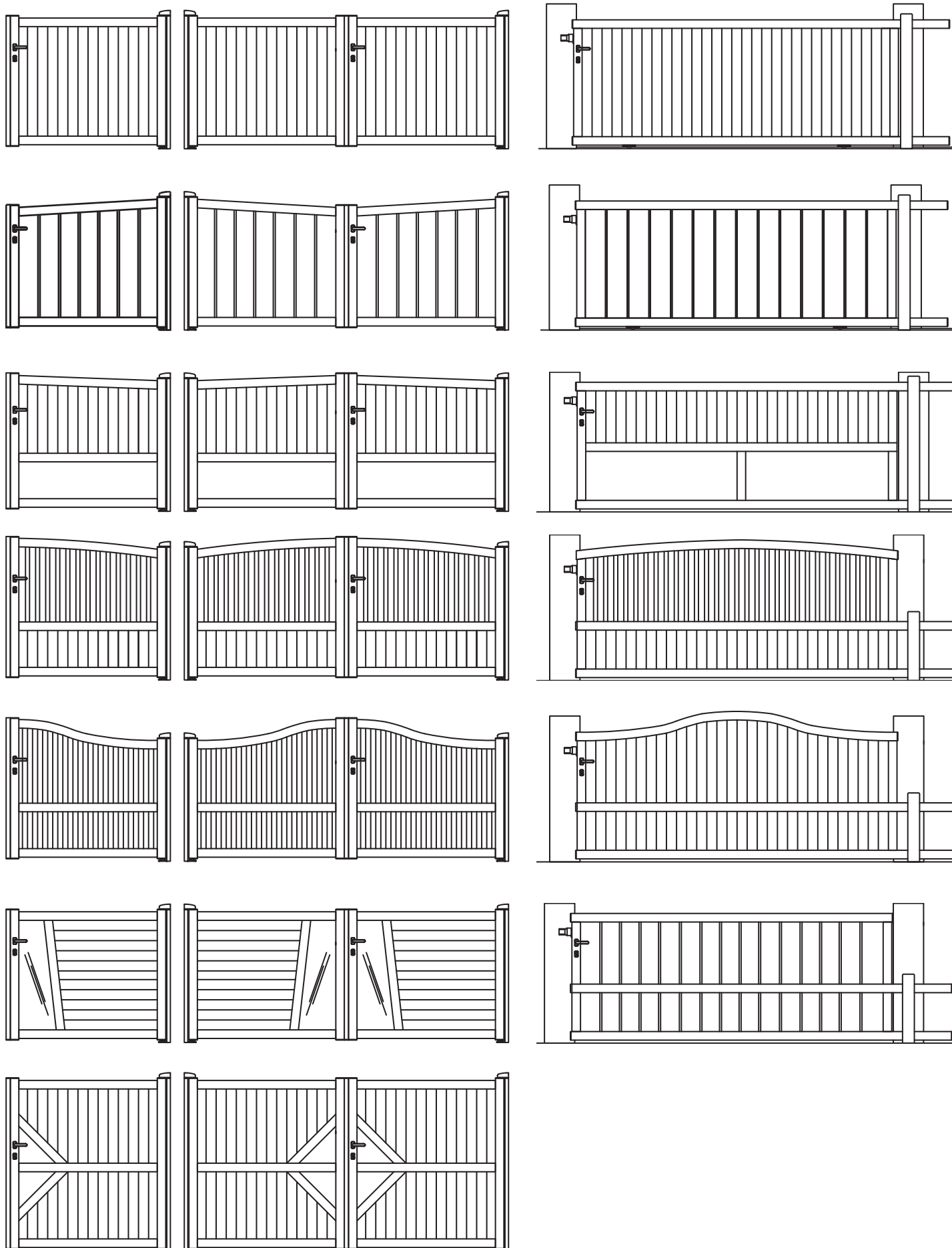

Pormenores de Montagem

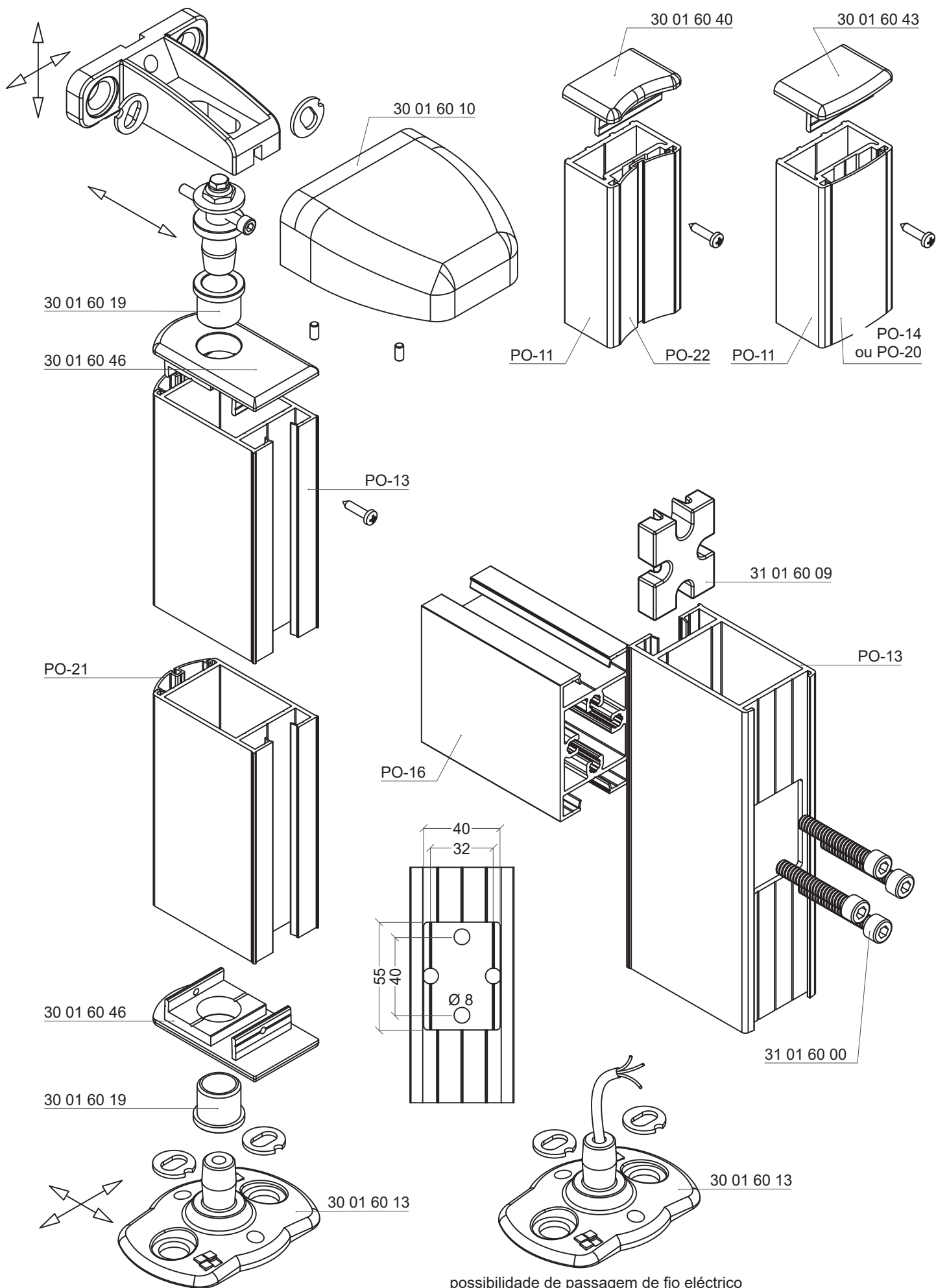

Pormenores de Montagem

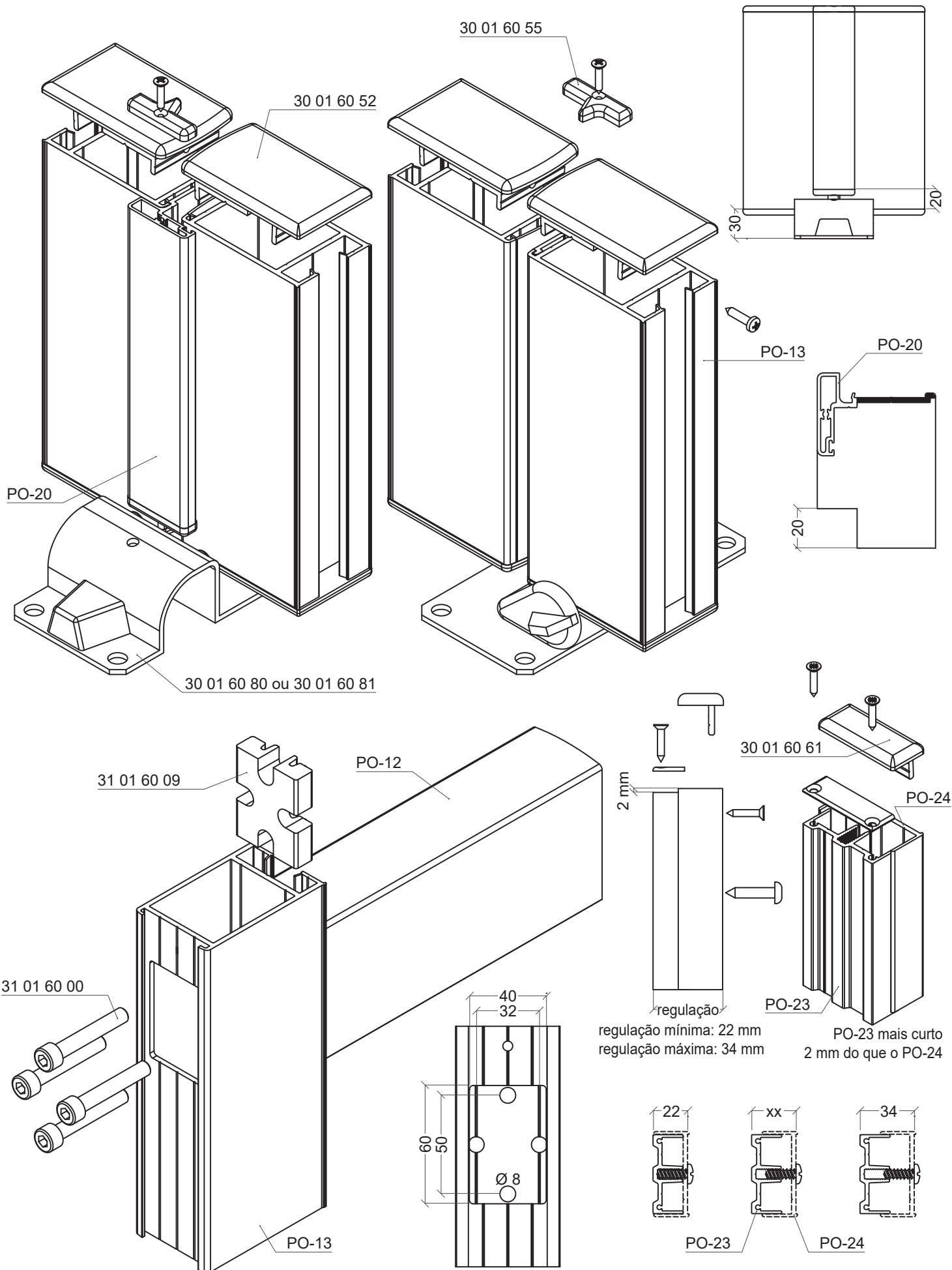

Pormenores de Montagem

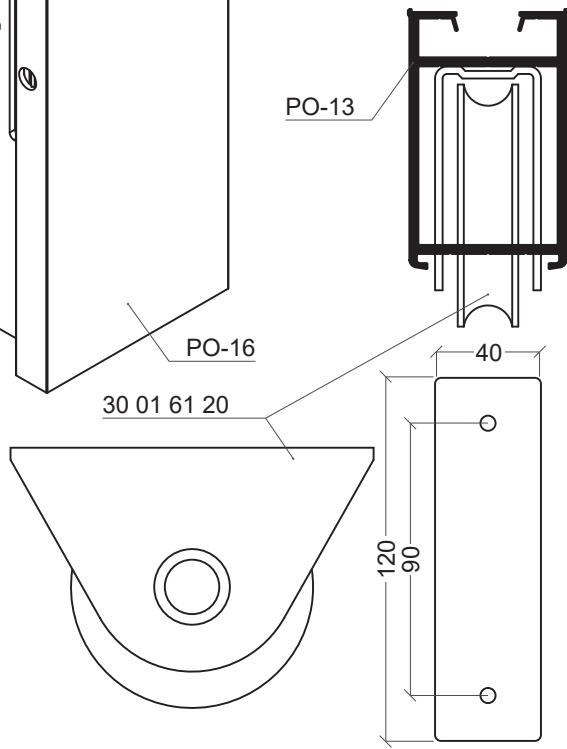
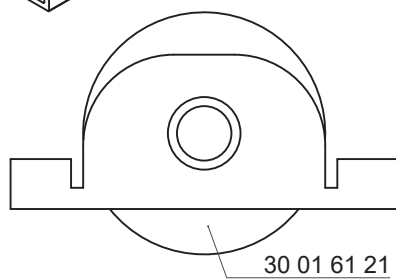
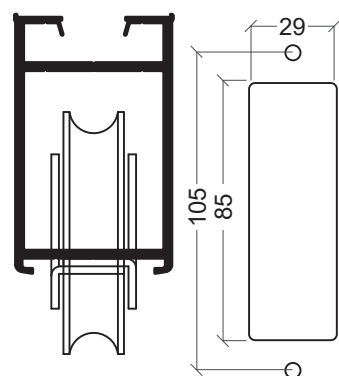
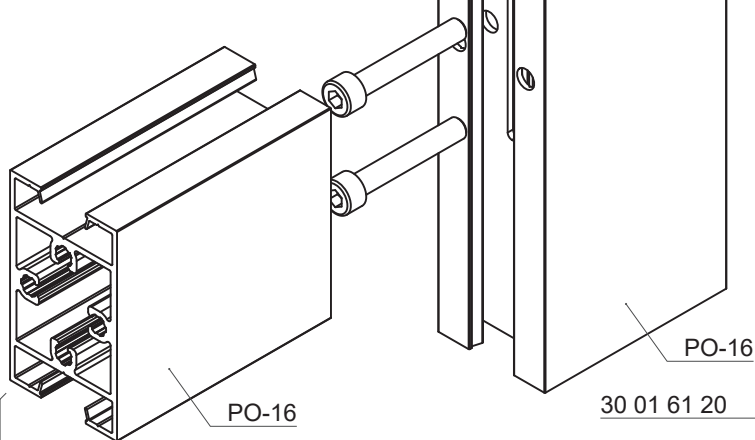
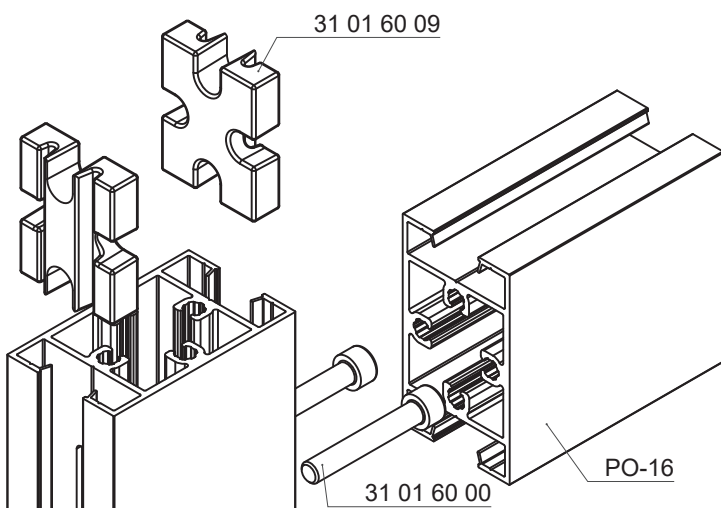
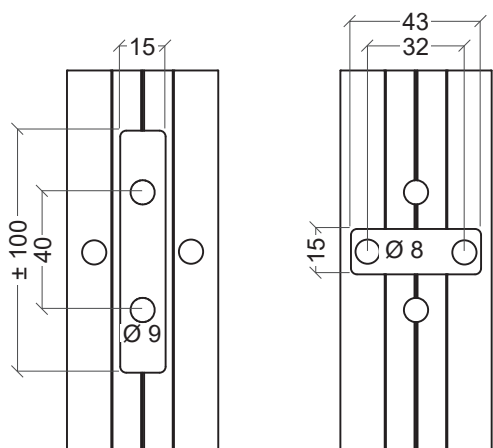
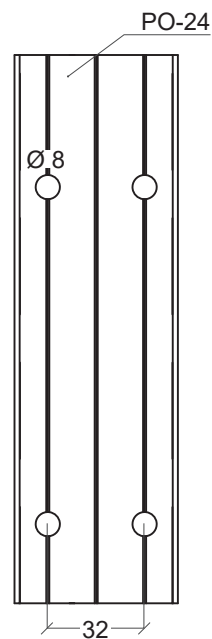
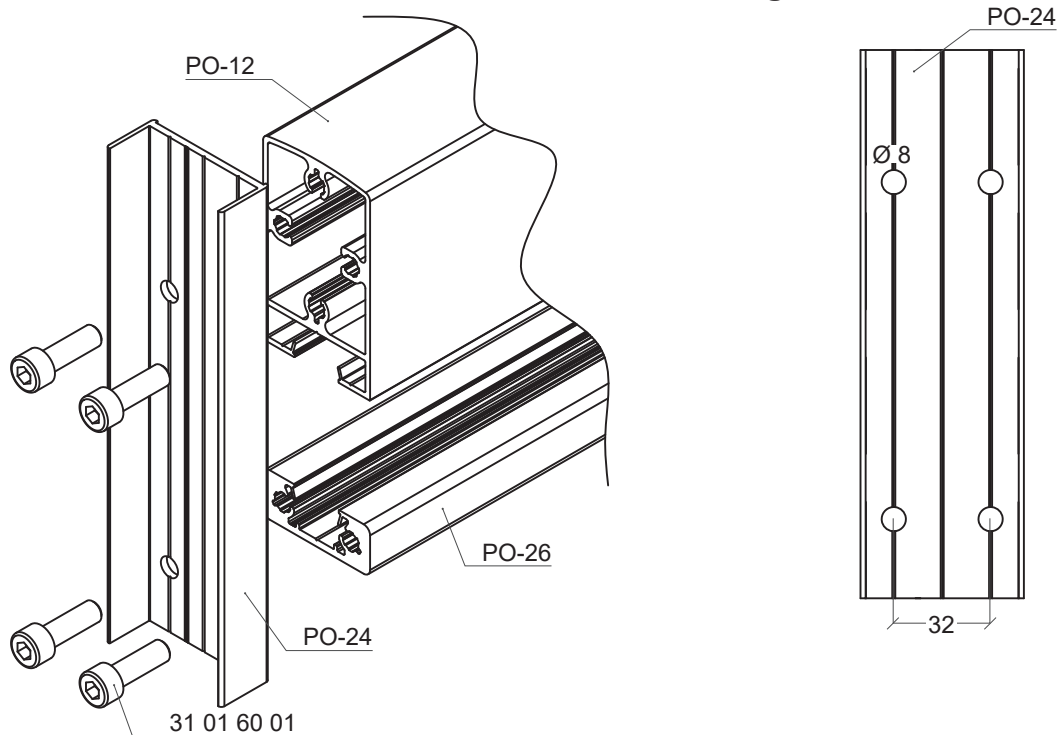

Sede e Fábrica

Zona Industrial de Oiã - Apt. 6
3770-908 Oiã - Oliveira do Bairro
T: (+351) 234 729 420
F: (+351) 234 729 429
E: anicolor@anicolor.pt

Filiais

Algarve
Área Emp. de Marim, Lote 1B
8700-221 Olhão
T: (+351) 289 703 867
F: (+351) 289 240 914
E: algarve@anicolor.pt

Castelo Branco
Azenha da Mina - Carvalhal
6230-801 Valverde - Fundão
T: (+351) 275 771 575
F: (+351) 275 771 573
E: castelobranco@anicolor.pt

Guarda
Parque Industrial da Guarda
6300-625 Guarda
T: (+351) 271 227 801
F: (+351) 271 227 802
E: guarda@anicolor.pt

Lisboa
R. General Barnabé Ferreira
2715-295 Dona Maria - Alm. do Bispo
T: (+351) 219 816 783
F: (+351) 218 647 011
E: lisboa@anicolor.pt

S. J. Madeira
Zona Industrial de Cesar
3701-906 Cesar - S. J. da Madeira
T: (+351) 256 858 152
F: (+351) 256 858 153
E: sjmadeira@anicolor.pt

Aveiro
Zona Industrial de Oiã - Apt. 6
3770-908 Oiã - Oliveira do Bairro
T: (+351) 234 729 422
F: (+351) 234 729 421
E: aveiro@anicolor.pt

Coimbra
Rua do Fetal, 28
3020-927 Torre de Vilela - Coimbra
T: (+351) 239 491 070
F: (+351) 239 491 328
E: coimbra@anicolor.pt

Leiria
Rua da Granja, 722
Zona Industrial da Zicofa
2420-397 Leiria
T: (+351) 244 471 657
F: (+351) 244 471 658
E: leiria@anicolor.pt

Porto
Zona Industrial nº 228 AZ
4580-565 Lordelo
T: (+351) 255 864 936
F: (+351) 224 152 517
E: porto@anicolor.pt

Viseu
Estrada Nacional Nº 2 - Muna
3510 Lordosa - Viseu
T: (+351) 232 912 343
F: (+351) 232 240 906
E: viseu@anicolor.pt

ALGARVE

AVEIRO

CASTELO BRANCO

COIMBRA

GUARDA

LEIRIA

LISBOA

PORTO

S.J. MADEIRA

WISEU

ESPANHA

ANGOLA

BRASIL

