

www.anicolor.pt

**SISTEMA DE
CORRER - 71 MM**

**SISTEMA
CORREDERA - 71 MM**

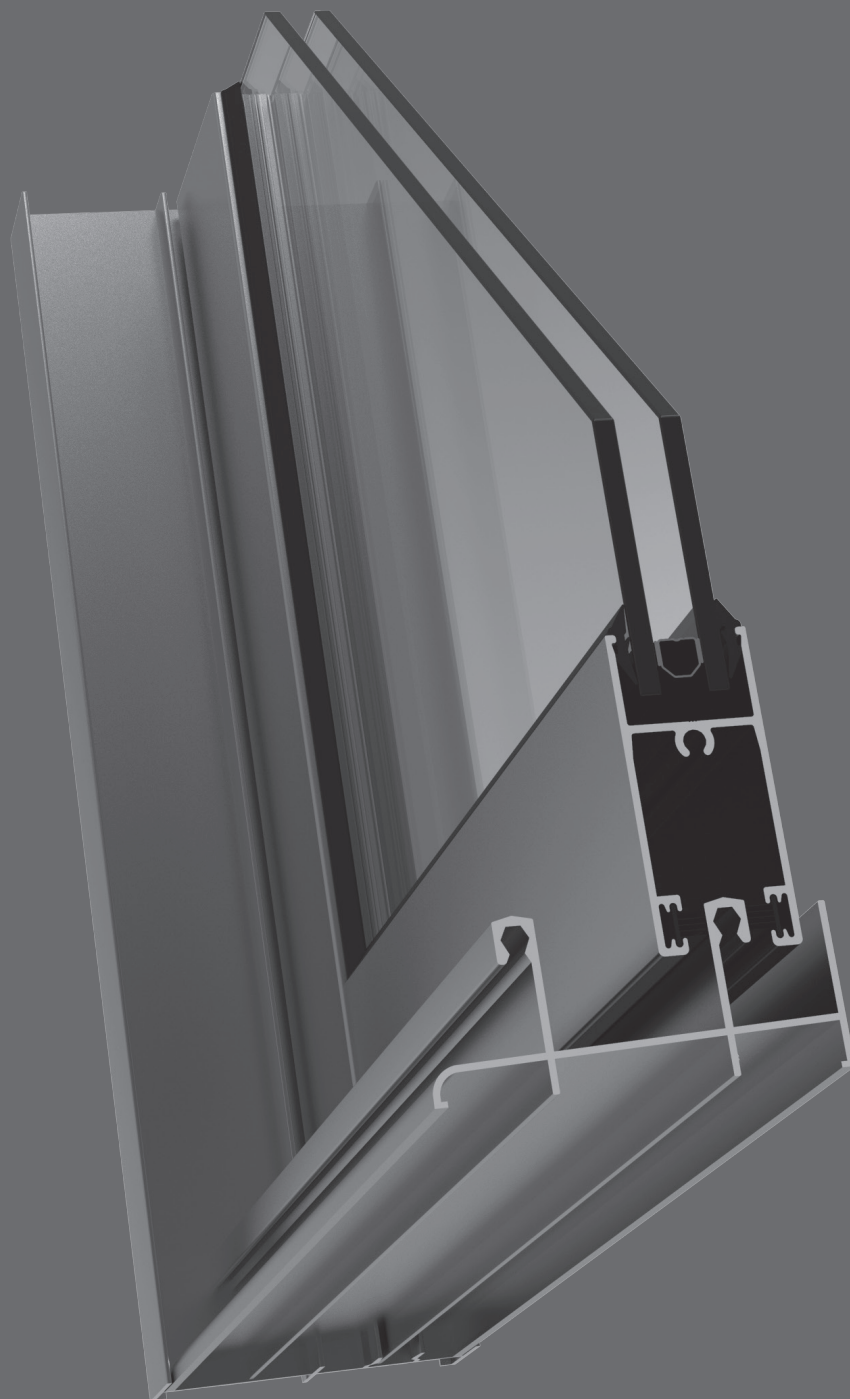

CO

SISTEMA CO

Sistema de correr - 71 mm

CARACTERÍSTICAS DO SISTEMA

Sistema de alumínio tradicional para execução de vãos de correr.

PERFIS DE ALUMÍNIO

Os perfis de alumínio são extrudidos na liga de alumínio 6060 para arquitetura de acordo com norma NP EN 12020-02.
Espessura média dos perfis de alumínio de 1.3mm.

AROS FIXOS

Secção do aro fixo de 2 guias de 70.5mm para montagem a corte recto;
Secção do aro fixo de 3 guias de 106.5mm para montagem a corte recto.

AROS MÓVEIS

Secção dos aros móveis de 27.8mm para montagem a corte recto.
Enchimento de 4mm a 18mm.

DIMENSIONAMENTO E MANOBRABILIDADE

Peso máximo de 80 kg por folha;
Possibilidades de abertura: 2, 3, 4 folhas e tri-rail, móveis e/ou fixos.

SISTEMA CO

Sistema corredera - 71 mm

CARACTERÍSTICAS DEL SISTEMA

Sistema de alumínio para ejecución de huecos correderos.

PERFILES DE ALUMINIO

Los perfiles de aluminio son extrudidos en la aleación de aluminio 6060 para arquitectura de acuerdo con la norma NP EN 12020-02.
Espesor medio de los perfiles de aluminio de 1.3 mm

MARCOS

Sección de marco fijo con 2 guías de 70.5 mm para montaje en sección recta;
Sección de marco fijo con 3 guías de 106.5 mm para montaje en sección recta;

HOJAS

Sección de hojas de corte recto de 27.8 mm;
Acristalamiento de 4 mm a 18 mm;

DIMENSIONAMENTO Y MANIOBRABILIDAD

Peso máximo de 80 kg por hoja;
Possibilidades de abertura: 2, 3,4 hojas y tricarril con hojas correderas y/ó fijas;

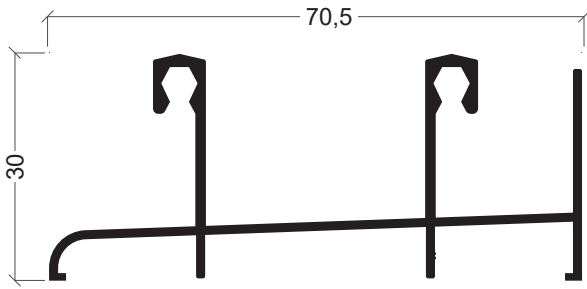

CO-11
Soleira
Marco inferior

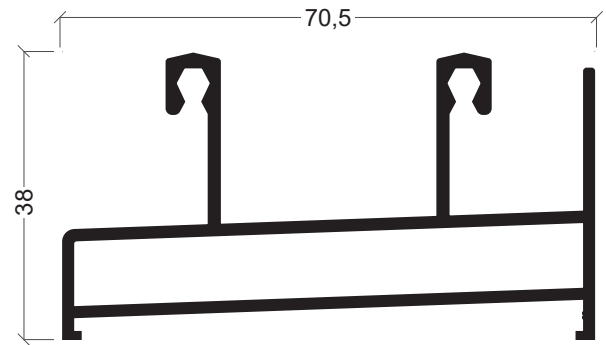

CO-01
Soleira com Caixa
Marco inferior

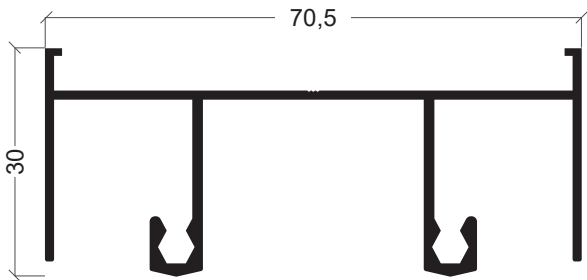

CO-05
Padieira
Marco superior

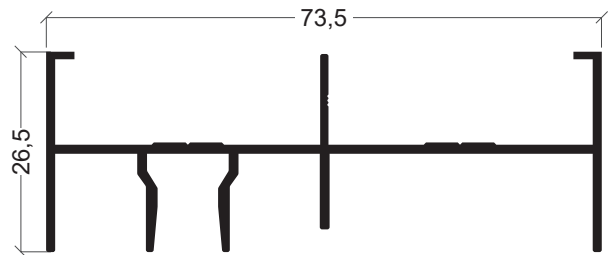

CO-06
Ombreira
Marco lateral

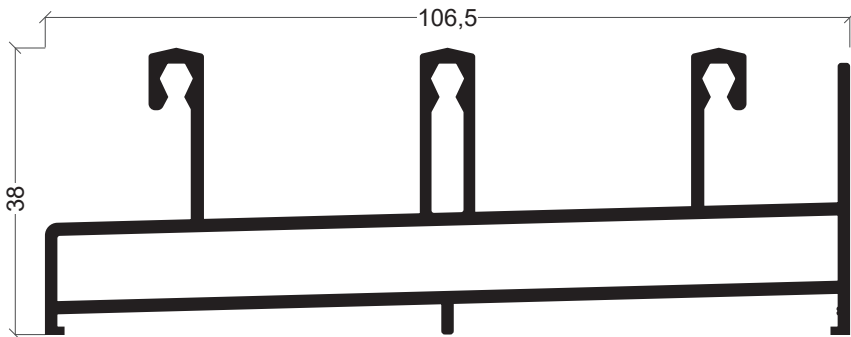

CO-21
Soleira Tri-rail
Marco inferior tricarril

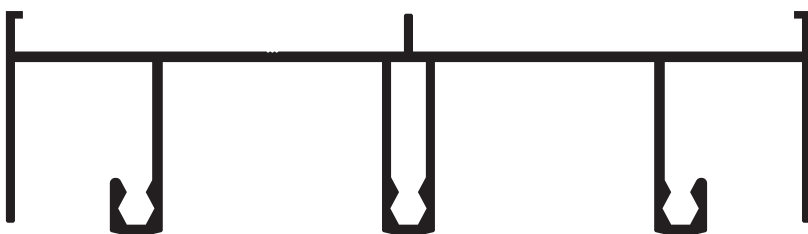

CO-25
Padieira Tri-rail
Marco superior tricarril

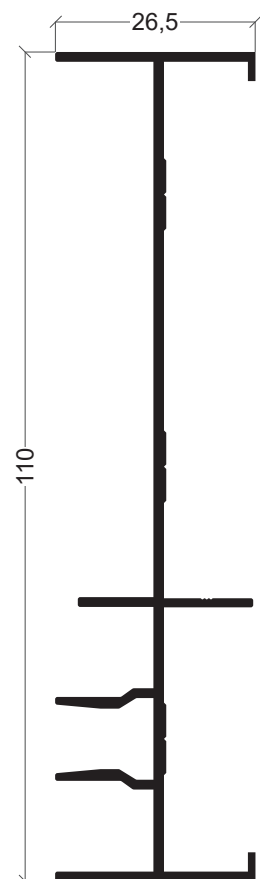

CO-26
Ombreira Tri-rail
Marco lateral tricarril

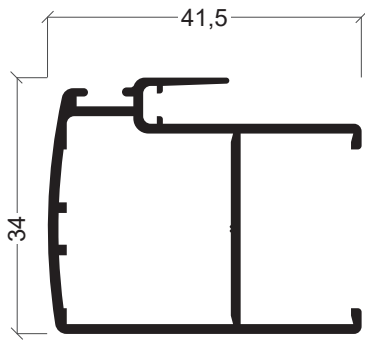

CO-17
Aro móvel central
Hoja central

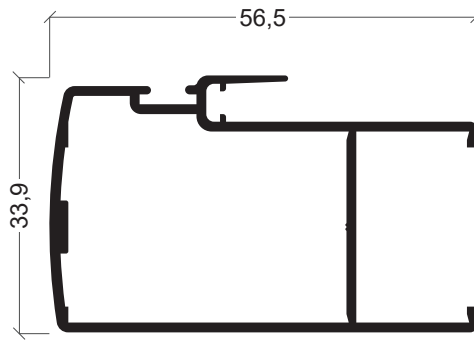

CO-09
Aro móvel central
Hoja central

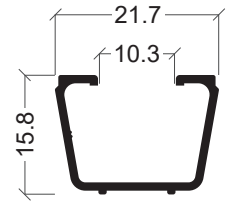

CO-13
Redutor
Reductor

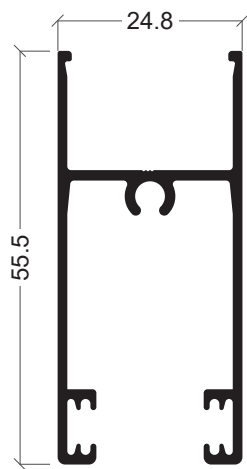

CO-02
Aro móvel carrinho
Hoja ruedas

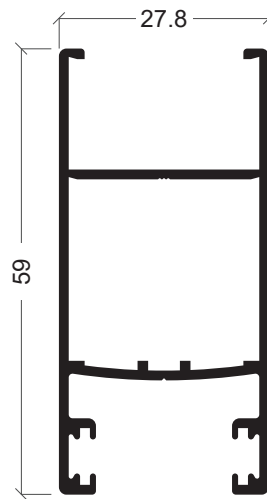

CO-10
Aro móvel lateral
Hoja lateral

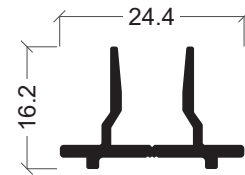

CO-18
União 4 folhas
Unión 4 hojas

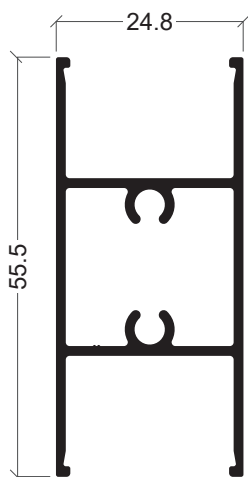

CO-24
Travessa
Travessaño

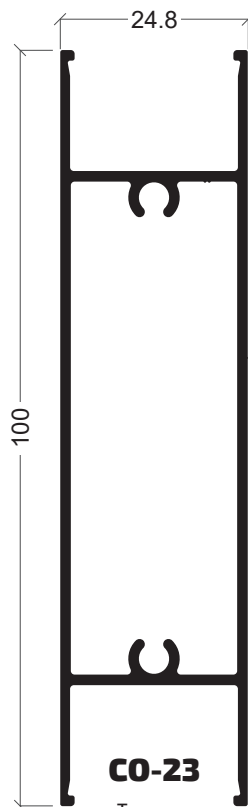



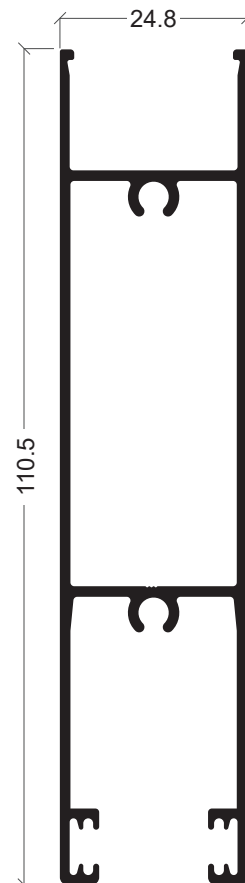



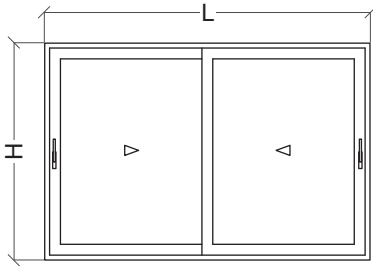

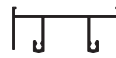

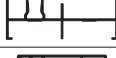

CO-23
Travessa
Travessaño



CO-22
Almofada carrinho
Zócalo ruedas

Janela 2 folhas correr • Ventana 2 hojas correr

PERFIS • PERFIS

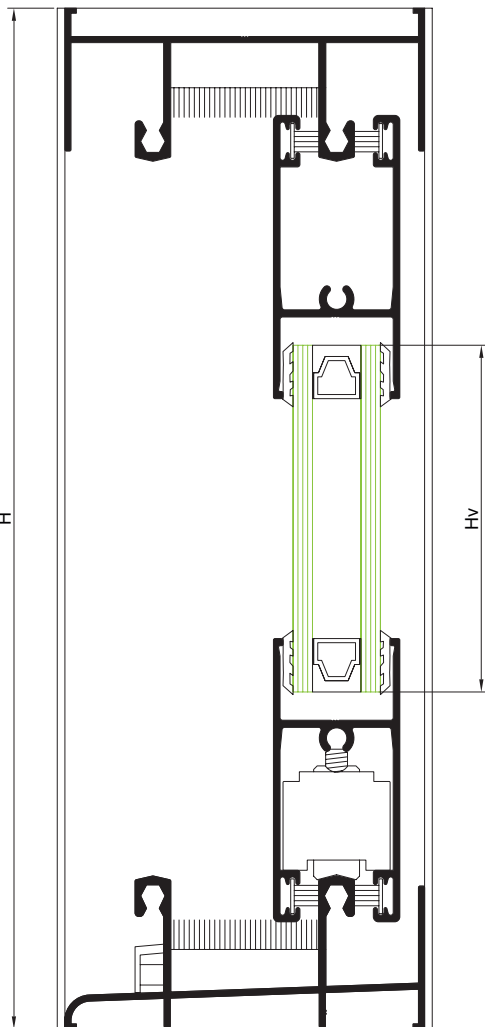
| DESENHO • DESEÑO | REF. | DESCRIÇÃO • DESCRIPCIÓN | CORTE CORTE | QUANTIDADE CANTIDAD | MEDIDAS • MEDIDA |
|-----------------------------------------------------------------------------------|-------|------------------------------------|-------------------------------------------------------------------------------------|---------------------|------------------|
|  | CO-05 | Padieira • Marco superior |  | 1 | L-28mm |
|  | CO-11 | Soleira • Marco inferior |  | 1 | L-28mm |
|  | CO-06 | Ombreira • Marco lateral |  | 2 | H |
|  | CO-10 | Aro móvel lateral • Hoja lateral |  | 2 | H-42mm |
|  | CO-09 | Aro móvel central • Hoja central |  | 2 | H-42mm |
|  | CO-02 | Aro móvel carrinho • Hoja carrinho |  | 4 | L/2-8.5mm |

VIDRO • VIDRIO

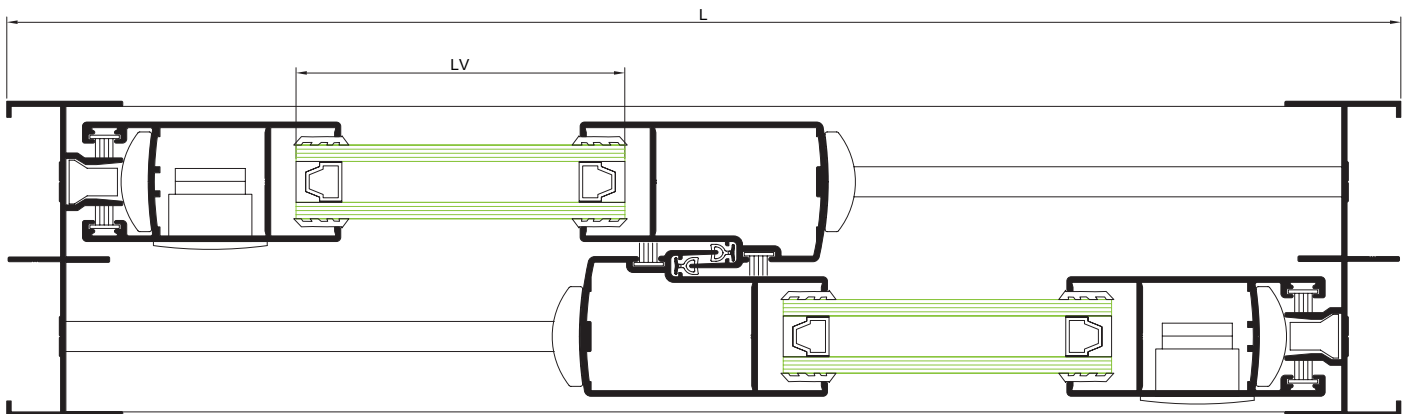
| | |
|--------------|---------------|
| Hv = H-131mm | Lv = L/2-82mm |
|--------------|---------------|



Janela 4 folhas correr • Ventana 4 hojas correr

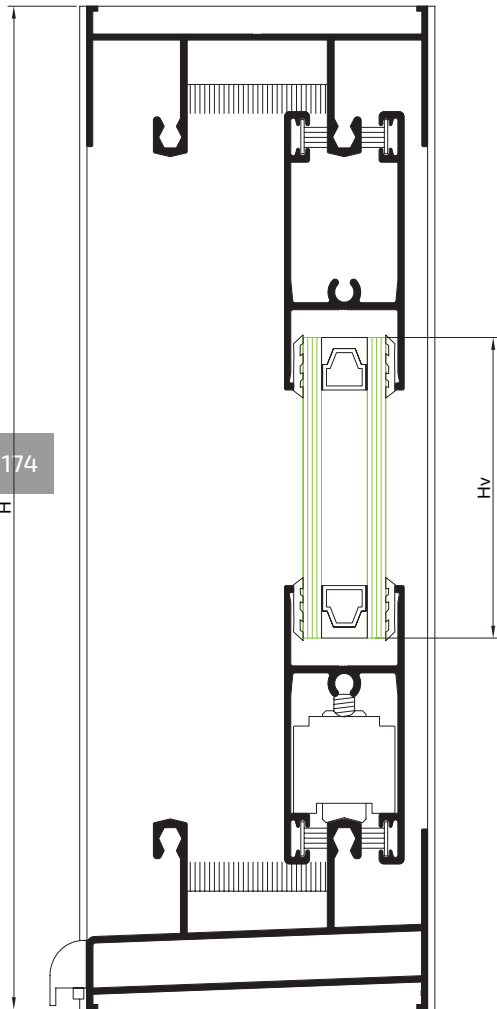
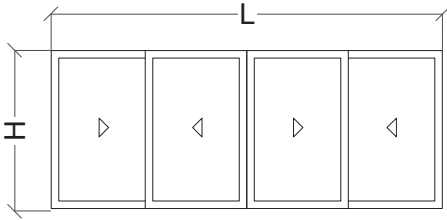

PERFIS • PERFIS

| DESENHO • DISEÑO | REF. | DESCRIÇÃO • DESCRIPCIÓN | CORTE CORTE | QUANTIDADE CANTIDAD | MEDIDAS • MEDIDA |
|------------------|-------|------------------------------------|-------------|---------------------|------------------|
| | CO-05 | Padieira • Marco superior | | 1 | L-28mm |
| | CO-01 | Soleira • Marco inferior | | 1 | L-28mm |
| | CO-06 | Ombreira • Marco lateral | | 2 | H |
| | CO-10 | Aro móvel lateral • Hoja lateral | | 4 | H-50mm |
| | CO-09 | Aro móvel central • Hoja central | | 4 | H-50mm |
| | CO-02 | Aro móvel carrinho • Hoja carrinho | | 8 | L/4-2mm |
| | CO-18 | União 4 folhas • Unión 4 hojas | | 1 | H-50mm |

VIDRO • VIDRIO

| | |
|--------------|---------------|
| Hv = H-139mm | Lv = L/4-75mm |
|--------------|---------------|

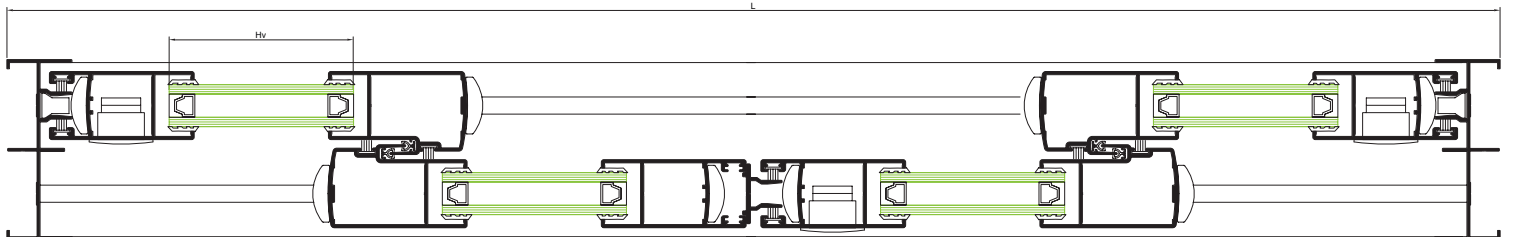

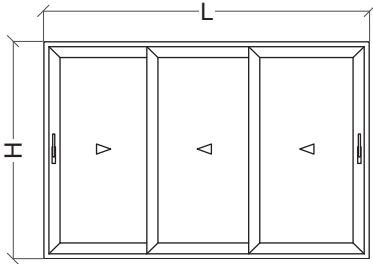
Porta 3 folhas correr tri-rail • Puerta 3 hojas corredera tri-rail

PERFIS • PERFIS

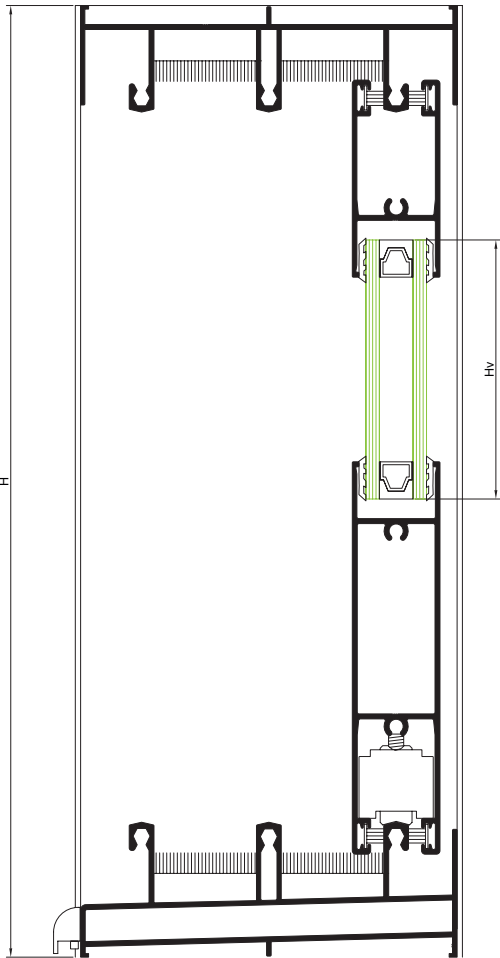
| DESENHO • DISEÑO | REF. | DESCRIÇÃO • DESCRIPCIÓN | CORTE CORTE | QUANTIDADE CANTIDAD | MEDIDAS • MEDIDA |
|------------------------------------------------------------------------------------|-------|------------------------------------|--------------------------------------------------------------------------------------|---------------------|------------------|
|  | CO-25 | Padieira • Marco superior |  | 1 | L-28mm |
|  | CO-21 | Soleira • Marco inferior |  | 1 | H |
|  | CO-26 | Ombreira • Marco lateral |  | 2 | H-50mm |
|  | CO-10 | Aro móvel lateral • Hoja lateral |  | 2 | H-50mm |
|  | CO-09 | Aro móvel central • Hoja central |  | 4 | H-42mm |
|  | CO-22 | Almofada Carrinho • Zócalo Ruedas |  | 3 | (L/3)+11mm |
|  | CO-02 | Aro móvel carrinho • Hoja carrinho |  | 3 | (L/3)+11mm |

VIDRO • VIDRIO

| | |
|--------------|-----------------------------------------------|
| Hv = H-194mm | Lv = (L/3) - 62mm / Lv central = (L/3) - 75mm |
|--------------|-----------------------------------------------|

